



ANNUAL REPORT 2019-20



Ministry of Electronics & Information Technology
GOVERNMENT OF INDIA



myGov

150

Ba-Bapu
@150 Quiz

150th Birth Anniversary
Celebrations of
Kasturba &
Mahatma Gandhi

Quiz MyGov.in



Inauguration of
CSC WOMEN VLE WORKSHOP
on CSC Diwas

By
SHRI RAVI SHANKAR PRASAD
Minister of Electronics, Information Technology &
Information Communication and Language

In august presence
of
DR. ANJANA
Minister of Skill Development & Entrepreneurship

14th September, 2018
Vignyan Bhawan, New Delhi



D. N. JOSHI AGRI
MEMORIAL LECTURE
2018

3rd August 2018
Vignyan Bhawan, New Delhi

National Informatics Centre
Ministry of Electronics & Information Technology
NIC



Ministry of Electronics and Information Technology

**India: Towards A Global
Electronics Hub**
CEOs Round Table
with
Shri Ravi Shankar Prasad
Minister for Electronics, Information
Technology, Communication and Language

14th September, 2018
Vignyan Bhawan, New Delhi



सत्यमेव जयते

Ministry of Electronics & Information Technology (MeitY)
Government of India

ANNUAL REPORT
2019–20

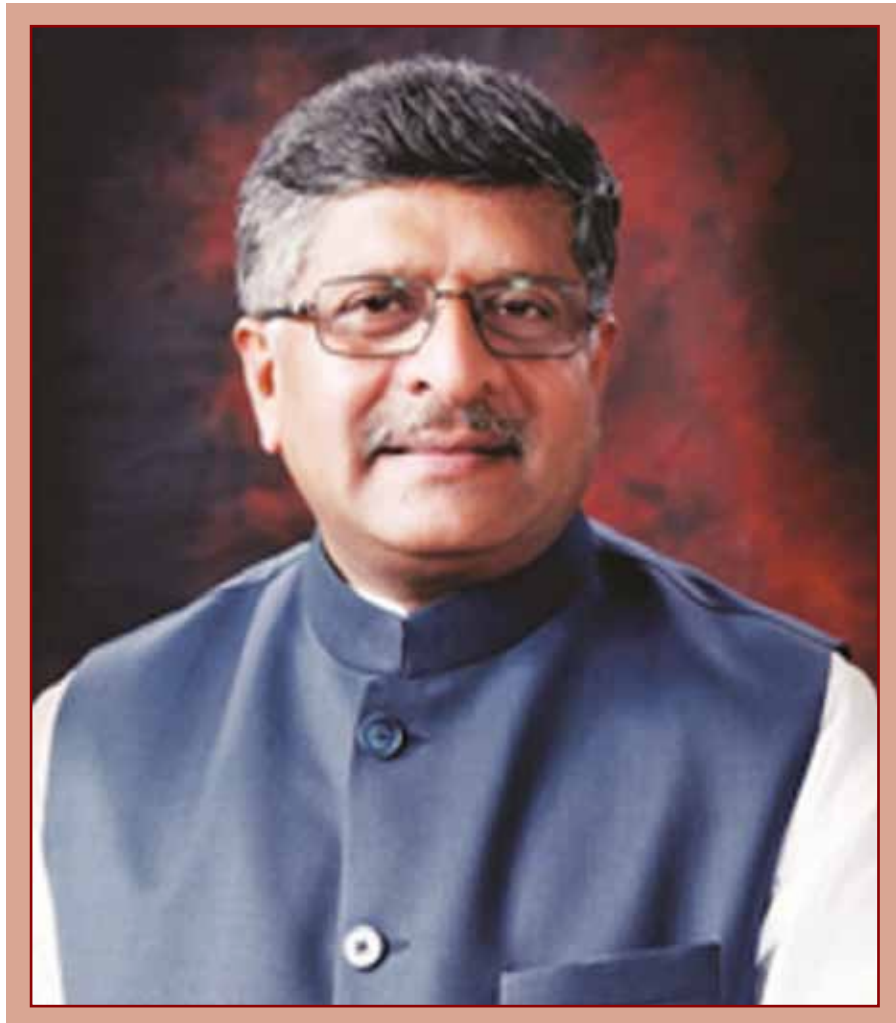

Contents

Executive Summary		15 – 16
1.	Overview: Vision, Mission, Objectives, Structure and Functions of MeitY	17 – 20
1.1	Introduction	
1.2	Vision	
1.3	Mission	
1.4	Objectives	
1.5	Functions of Ministry of Electronics & Information Technology	
1.6	Organization Structure	
1.7	Client's/Citizen's Charter (CCC)	
2.	Digital India: Power to Empower	21 – 104
2.1	Digital Infrastructure as a Core Utility to Every Citizen	
2.1.1	Digital Identity– Aadhaar: An efficient and targeted Service Delivery Platform	
2.1.1.1	e-Pramaan – A National Authentication Service	
2.1.1.2	Online e-Sign (e-Hastakshar)	
2.1.2	State Wide Area Network (SWAN)	
2.1.3	State Data Centre (SDC)	
2.1.4	GI Cloud (MeghRaj)	
2.1.5	Service Delivery Gateway	
2.1.6	National Knowledge Network (NKN)	
2.1.7	Mobile Seva Platform	
2.1.8	Geographical Information System (GIS)	
2.1.9	High Speed Broadband Connectivity	
2.1.10	Public Internet Access Programme (including Wi-Fi in 5 Universities)	
2.2	Governance and Services on Demand	
2.2.1	e-District Mission Mode Projects	
2.2.2	All Services through online & Mobile	
2.2.2.1	Programme on “Good Governance and Best Practices”	
2.2.2.2	World Bank assisted “India: e-Delivery of Public Services” Project	
2.2.2.3	National Scholarships Portal	
2.2.2.4	Digital Locker & other Initiatives	

- 2.2.2.5 Enabling All Schools with Virtual Class Rooms
- 2.2.2.6 Open Government Data (OGD) Platform for National Data Sharing & Accessibility Policy (NDSAP)
- 2.2.2.7 Electronic Transaction Aggregation & Analysis Layer (eTaal 2.0)
- 2.2.2.8 e-Hospital Project/ Online Registration System (ORS)
- 2.2.2.9 Rapid Assessment System (RAS)
- 2.2.2.10 Jeevan Pramaan
- 2.2.2.11 Aadhaar Enabled Biometric Attendance System (AEBAS)
- 2.2.2.12 PRAGATI (Pro-Active Governance And Timely Implementation)
- 2.2.2.13 Digitized India Platform (DIP)
- 2.2.3 **Financial Transactions Electronic & Cashless**
 - 2.2.3.1 Direct Benefit Transfer (DBT)
- 2.2.4 **Technical & Other Support**
 - 2.2.4.1 e-Gov App Store
 - 2.2.4.2 Development of Common Minimum Framework (CMF) for Government Websites
 - 2.2.4.3 India Portal
 - 2.2.4.4 India Enterprise Architecture (IndEA)
 - 2.2.4.5 Capacity Building Scheme 2.0
- 2.2.5 **Common Services Centre (CSC 2.0 – A Way forward Project)**
- 2.3 Digital India Initiatives by NIC**
 - 2.3.1 **Agriculture**
 - 2.3.1.1 Soil Health Card Portal
 - 2.3.1.2 PM Kisan-Pradhan Mantri Kisan Samman Nidhi
 - 2.3.1.3 Integrated Fertilizer Management System (iFMS)/DBT in Fertilizers (eUrvarak)
 - 2.3.2 **Health & Family Welfare**
 - 2.3.2.1 e-Hospital
 - 2.3.2.2 Beneficiary Identification System (PM-JAY)
 - 2.3.2.3 Central Government Health Scheme (CGHS)
 - 2.3.2.4 Reproductive & Child Health (RCH)
 - 2.3.2.5 Direct Benefit Transfer – Health (DBT)
 - 2.3.2.6 CollabDDS
 - 2.3.3 **Finance**
 - 2.3.3.1 Public Financial Management System (PFMS)
 - 2.3.3.2 e-Way Bill
 - 2.3.3.3 GST Prime
 - 2.3.3.4 Indian Customs EDI Systems (ICES)

- 2.3.4 Education
 - 2.3.4.1 E-Counselling
 - 2.3.4.2 National Scholarships Portal
 - 2.3.4.3 UDISE+ : Unified District Information on School Education
 - 2.3.4.4 AISHE : All India Survey of Higher Education
 - 2.3.4.5 Mid-Day Meals Automated Reporting & Management System
 - 2.3.4.6 ShalaDarpan
- 2.3.5 Transport
 - 2.3.5.1 eChallan
 - 2.3.5.2 mParivahan
 - 2.3.5.3 Pollution under Control Certificate (PUC)
- 2.3.6 Inclusive Development
 - 2.3.6.1 Swachh Bharat Mission
 - 2.3.6.2 Pradhan Mantri Adarsh Gram Yojana (PMAGY)
 - 2.3.6.3 Mahatma Gandhi National Rural Employment Guarantee Act (MGNREGA)
 - 2.3.6.4 National Generic Document Registration System (NGDRS)
- 2.3.7 Food & Public Distribution
 - 2.3.7.1 Targeted Public Distribution System
 - 2.3.7.2 Confonet (Computerisation & Computer networking of Consumer Fora in the Country)
- 2.3.8 Law & Justice
 - 2.3.8.1 eCourts
 - 2.3.8.2 eGovernance support to Supreme Court
 - 2.3.8.3 National Tribunal
 - 2.3.8.3.1 National Green Tribunal
 - 2.3.8.3.2 National Company Law Tribunal
 - 2.3.8.4 Virtual Courts
- 2.3.9 Home Affairs
 - 2.3.9.1 Interoperable Criminal Justice Systems (ICJS)
 - 2.3.9.2 National Cyber Crime Reporting Portal 2.0
 - 2.3.9.3 E-Prison
 - 2.3.9.4 E-Visa
- 2.3.10 Social Welfare & Skill Development
 - 2.3.10.1 National Social Assistance Programme (NSAP)
 - 2.3.10.2 National Overseas Scholarship Scheme (NOS)
 - 2.3.10.3 National Rural Livelihood Mission (NRLM)
- 2.3.11 Good Governance & Enforcement
 - 2.3.11.1 e-Office

- 2.3.11.2 Service Plus
 - 2.3.11.3 Manav Sampada – A Tool for Human Resource Management
 - 2.3.11.4 Dashboard for Analytical Review of Projects Across Nation (Darpan)
 - 2.3.11.5 Aadhaar Authentication Services
 - 2.3.11.6 Jeevan Pramaan
 - 2.3.11.7 Public Grievances
 - 2.3.11.7.1 CPGRAMS (Central Public Grievance Redress & Monitoring System)
 - 2.3.11.7.1 Junsunwayi
 - 2.3.11.8 Swagatam Portal
 - 2.3.11.9 Unified Shram Suvidha Platform (USSP)
 - 2.3.11.10 Centralized eAuction System
- 2.4 Digital Empowerment of Citizens**
- 2.4.1 DigiDhan - Digital Payments
 - 2.4.2 E-Learning
 - 2.4.2.1 Language Computing
 - 2.4.3 Initiatives on Accessibility
- 2.5 Digital India Publications**
- 2.5.1 Release of Yojana on “Citizen Centric e-Services”
- 2.6 Celebration of 150th birth anniversary of Mahatma Gandhi**
- 2.7 100 days Programme of Ministry of Electronics & Information Technology (MeitY)**
- 2.8 Sectoral Group of Secretaries (SGoS) – Technology**

3. Make in India: Electronics Manufacturing

105– 126

- 3.1 Modified Special Incentive Package (M-SIPS)
- 3.2 Electronics Manufacturing Clusters (EMC)
- 3.3 Electronics Development Fund (EDF)
- 3.4 Compulsory Safety Standards for Electronics
- 3.5 Growth of Electronics Sector
- 3.6 Public Procurement (Preference to Make in India) Order 2017
- 3.7 Tariff Rationalization
- 3.8 National Policy on Electronics (NPE) 2019
- 3.9 Centre for Excellence in Electronics & ICT Application
 - 3.9.1 National Centre for Excellence for Large Area Flexible Electronics
 - 3.9.2 National Centre for Excellence in Technology for Internal Security (NCETIS)
 - 3.9.3 Next General AMOLED Displays, OLED Lighting & OPV Products

3.10 Marketing and Promotions to attract Investment in ESDM sector

- 3.10.1 State & National Level Workshops
- 3.10.2 Visits to attract Investments in ESDM Sector
- 3.10.3 Handholding & Facilitation for Investors to attract investment in ESDM Sector
- 3.10.4 Socila Media Participation
- 3.10.5 B2B Portal

4. Make in India: Software & Services

127 – 139

- 4.1 Global Perspective**
- 4.2 BPM Industry Promotion**
- 4.3 National Policy on Software Products**
 - 4.3.1 Indian Software Product Registry
 - 4.3.2 MeitY-NASSCOM Startup – Women Entrepreneur Awards 2019 for Software Products
- 4.4 Software Technology Park Scheme**
- 4.5 Domain Specific Centres of Excellence Across the Country by STPI**
- 4.6 International Cooperation**
- 4.7 Cooperation through Bilateral Interaction**
 - 4.7.1 Software Products as a Tool for Economic Growth
 - 4.7.2 International Projects in ICT

5. Innovate and Design in India

140 – 170

- 5.1. Creation of Research Eco-System**
 - 5.1.1 National Supercomputing Mission (NSM)
 - 5.1.2 R&D and IP development
 - 5.1.2.1 R & D in IT
 - 5.1.2.2 Microelectronics Development and Nanotechnology Initiatives
 - 5.1.2.3 Convergence, Communications & Broadband Technologies & Strategic Electronics
- 5.2 R&D for Translation**
 - 5.2.1 Initiatives under Electronics Components and Material Development
 - 5.2.2 Technology Development & Demonstration for Indian Industries
 - 5.2.2.1 National Mission on Power Electronics Technology (NaMPET-II)
 - 5.2.2.2 Realization of Series Connection of Silicon Carbide (SiC) Devices in Converters with High Frequency Link Bidirectional DC-DC Converter for Grid Interfaces
 - 5.2.2.3 Spectroscopic Platform for Detection of Adulteration in Milk
 - 5.2.2.4 Development of Electric Vehicle Sub-System
 - 5.2.3 Medical Equipments/Tools
 - 5.2.4 Initiatives under Microelectronics Development and Nanotechnology

5.3 Centres of Excellence

5.3.1 Nanotechnology Centres

5.3.2 Innovation & IPR

5.4 R&D for Cyber Security

5.5 R&D for Societal Out Reach

5.5.1 Medical Tools, Equipments & Software

5.5.2 Agriculture

5.5.2.1 Smart Warehouses Technology

5.5.2.2 Design and Development of Automated Aquaponics System for Vertical Farming in India

5.5.2.3 Development of Autonomous Multipurpose Agricultural Robotic Platform

5.5.2.4 Electronic Waste Awareness Programme

5.5.2.5 Entrepreneurial Training Programme for Scheduled Caste Communities in Kerala

5.5.3 Healthcare

5.5.3.1 Point-of-Care Testing Device for Fingerprint Bilirubin Detection

5.5.3.2 Point-of-Care Testing Device for Pancreatic Amylase Detection

5.5.3.3 Point-of-Care Testing Device for Lung Condition Monitoring

5.5.3.4 Point-of-Care Testing Device for Parkinson's Patients

5.5.4 Societal Miscellaneous

5.5.4.1 Collaborative Intelligent Transport System Endeavour for Indian Cities

5.5.4.2 Automated Machine Vision System for Leather Surface Quality Discriminant Function Analysis

5.5.4.3 Design and Development of Anti-Eve Teasing Device for Women Safety

5.5.4.4 Enhancement, Field Testing, Training and Maintenance of DigiBunai™ (Open Source CAD Tool for Weaving)

5.5.5 Information Technology Research Academy (ITRA)

6. Internet Governance and Security Cyber Space

171 – 183

6.1 Internet Governance

6.1.1 Achievements

6.1.1.1 Engagement in International Forums/Meetings

6.1.1.2 R&D Project and Awareness Agenda under Internet Governance

6.2 National Internet Exchange of India (NIXI)

6.3 Security of Cyber Space

6.3.1 Cyber Law

6.3.2 National Cyber Security Policy

6.3.3 Indian Computer Emergency Response Team (CERT-In)

6.3.4 Cyber Surakshit Bharat

- 6.3.5 Grand Challenge for Start-ups
- 6.3.6 Notification for Preferential Market Access for Cyber Security Products
- 6.3.7 Online capacity-building on Cyber Law, Crime Investigation and Digital Forensics
- 6.3.8 R&D Projects under NCCC
- 6.3.9 National Critical Information Infrastructure Protection Centre (NCIIPC)
- 6.3.10 North Eastern Regional Computer Security Incident Response Team (NERCSIRT).

6.4 CERT-In Initiatives towards Security including Digital Payments

7. Skill India: Capacity Building

184– 190

7.1 Skill India

- 7.1.1 Post Graduate and Doctorate Level
- 7.1.2 Graduate level
- 7.1.3 Vocational and Skill development level
- 7.1.4 Capacity Building in Niche Areas
- 7.1.5 Grass root level
- 7.1.6 Create Skill Development Facilities in Deprived Areas through Strengthening of NIELIT
- 7.1.7 IT for Masses Programme
- 7.1.8 Re-skilling/up-skilling of IT professionals

8. Statutory Organisations

191 – 205

8.1 Authentication framework under the IT Act, 2000 - Controller of Certifying Authority

- 8.1.1 eSign on Electronic Signature Service for Aadhaar Holders

8.2 Unique Identification Authority of India (UIDAI)

- 8.2.1 Introduction
- 8.2.2 Value Proposition of Aadhaar
 - 8.2.2.1 Uniqueness
- 8.2.3 Approach and Strategy : Enrolment Ecosystem
- 8.2.4 Customer Relationship Management & Logistics
- 8.2.5 Authentication Eco System
- 8.2.6 Training, Testing and Certification Ecosystem
- 8.2.7 Intranet & Knowledge Management Portal
- 8.2.8 UIDAI Website
- 8.2.9 Unified Mobile App
- 8.2.10 Security and Privacy of Aadhaar
- 8.2.11 Aadhaar - A Tool for Governance Reform
- 8.2.12 Implementation of Official Language Policy in UIDAI
- 8.2.13 Details of Budget & Expenditurefor

8.3 Indian Computer Emergency Response Team (CERT-In)

9. Attached Offices and Societies

206 – 303

9.1 Centre for Development of Advance Computing (C-DAC).

- 9.1.1 High Performance Computing (HPC) and Cloud Computing
- 9.1.2 Professional Electronics, including VLSI and Embedded Systems
- 9.1.3 Multilingual Computing and Heritage Computing
- 9.1.4 Health Informatics
- 9.1.5 Cyber Security and Cyber Forensics
- 9.1.6 Software Technologies, including Free Open Source Software
- 9.1.7 Education and Training
- 9.1.8 North-East Initiatives
- 9.1.9 International Initiatives

9.2 Society for Applied Microwave Electronics Engineering & Research (SAMEER)

- 9.2.1 Laboratories and Core Competence
- 9.2.2 Major R&D activities

9.3 Centre for Materials for Electronics Technology (C-MET)

- 9.3.1 C-MET's Laboratories & their Core Competence
- 9.3.2 Products Developed by C-MET for different Applications
- 9.3.3 Technologies ready for Transfer to Industries
- 9.3.4 Research Performance Indicator
- 9.3.5 Major Pilot Plant and Infrastructure Facilities
- 9.3.6 C-MET's Future Areas of Research

9.4 ERNET India

- 9.4.1 MeitY-ERNET-NASSCOM Center of Excellence (CoE) for Internet of Things (IoT), Bengaluru
- 9.4.2 VSAT Services
- 9.4.3 PoPs (Points of Presence)
- 9.4.4 R&D Activities
- 9.4.5 Internet of Things (IoT) Management Framework for Smart Cities
- 9.4.6 Smart Building PLC Testbed
- 9.4.7 Cyber Performance and Tech-Culture Fusion Programmes under APAN Asi@ Connect Initiative
- 9.4.8 Domain Registration
- 9.4.9 Setting up of eClassroom Infrastructure in 50 Medical Colleges for MoHFW
- 9.4.10 Development/renovation of Government/State Government Websites accessible for Persons with Disabilities (PwD) as per GIGW /WCAG. 2.0 (A, AA level) standards

9.5 Government's IT infrastructure: National Informatics Centre (NIC)

9.5.1 About NIC

9.5.2 Network Services

9.5.2.1 NICNET

9.5.2.2 NKN

9.5.3 Data Centre & Cloud Services

9.5.3.1 Data Centre

9.5.3.2 National Cloud

9.5.3.3 Command and Control Centre

9.5.3.4 NIC-CERT

9.5.4 Cyber Security

9.5.4.1 Network Security

9.5.4.2 Application Security

9.5.5 Web and Messaging Services

9.5.5.1 Domain Name Registration

9.5.5.2 Email

9.5.5.3 SMS

9.5.5.4 VPN

9.5.5.5 GIMS

9.5.6 Video Conferencing & Webcast

9.5.6.1 Video conferencing

9.5.6.2 Webcast

9.5.7 GIS & Utility Mapping

9.5.7.1 GIS

9.5.7.2 Utility Mapping

9.5.8 Support Services

9.5.8.1 Digital NIC

9.5.8.2 Service Desk

9.5.8.3 IVRS

9.5.8.4 Chat Bot for NIC Service Desk

9.5.9 Capacity Building

9.5.9.1 e-Learning Building

9.5.9.2 Classroom based Training Programme

9.5.9.3 Executive Briefings

9.5.9.4 Induction Training for New Recruits

9.5.9.5 Digital India Internship (DII) Scheme for NIC

9.5.9.6 GuDApps Test

9.5.10 e-Governance Product and Services

- 9.5.10.1 S3WaaS
- 9.5.10.2 e-Granthalaya
- 9.5.10.3 Mobile Apps Store
- 9.5.10.4 NEVA (National e-Vidhan)
- 9.5.10.5 e-HRMS
- 9.5.10.6 e-Nivesh
- 9.5.10.7 e-Samikha
- 9.5.10.8 e-Suvidha
- 9.5.10.9 Parivesh
- 9.5.10.10 Bio Metric Attendance System
- 9.5.10.11 e-Taal
- 9.5.10.12 Automated Performance Smart-Board

9.5.11 E Governance Applications

- 9.5.11.1 IVFRT : Immigration, Visa and Foreign Registration & Tracking
- 9.5.11.2 India Portal
- 9.5.11.3 MyGov
- 9.5.11.4 Open Government Data (OGD)
- 9.5.11.5 National Power Portal
- 9.5.11.6 Platform for Effective Enforcement for No Child Labour (PENCiL)
- 9.5.11.7 Jan Shikshan Sansthan

9.5.12 NIC in States/UTs

9.5.13 Development of North Eastern Region (DoNER)

9.5.14 National Informatics Centre Services Inc. (NICSI)

9.5.15 International Collaboration

9.5.16 Centre of Excellence (CoE) and Software Development Unit (SDU)

- 9.5.16.1 Data Analytics
- 9.5.16.2 Artificial Intelligence
- 9.5.16.3 Application Security
- 9.5.16.4 NIC Software Development Units (SDU)
- 9.5.16.5 Open Technology Group
- 9.5.16.6 Lal Bahadur Shastri National Academy of Administration

9.5.17 Major Events

- 9.5.17.1 Technology-Conclave
- 9.5.17.2 Vision Insight and Voices as India goes Digital (VIVID)
- 9.5.17.3 Digital India Awards
- 9.5.17.4 International Yoga Day

- 9.5.17.5 Dr. N. Seshagri Memorial Lecture (DSML)
- 9.5.17.6 150 years of Celebrating the Mahatma
- 9.5.18 Media and Outreach
- 9.6 Standardization, Testing and Quality Certification (STQC) Directorate**
 - 9.6.1 Introduction
 - 9.6.2 Common Criteria (CC) Test Infrastructure
 - 9.6.3 National Facility for Quality Assessment of Biometric Devices
 - 9.6.4 Website Quality Certification
 - 9.6.5 Major Service Offered -Test and Calibration
 - 9.6.6 Major Safety Test Facility
 - 9.6.7 Continuing Participation in Space Programmes through Components Screening, Package & Modules testing and Environmental Testing.
 - 9.6.8 EVMs and VVPATs Testing-ETDC, Bengaluru and ETDC, Hyderabad
 - 9.6.9 Major Service Offered Training
 - 9.6.10 Activities in North-East Region (NER)
 - 9.6.11 Initiatives in Test & Calibration Service
 - 9.6.12 NABL Accreditation & Inter-Laboratory Comparison (ILC)
 - 9.6.13 Initiatives in IT Test & Assessment services
 - 9.6.14 Initiatives in Training Services in the Fields of Electronics & IT/Quality & Reliability
- 9.7 National Institute of Electronics and Information Technology (NIELIT)**
 - 9.7.1 Introduction
 - 9.7.2 R&D, Innovation & Design
 - 9.7.3 Capacity Building Projects
 - 9.7.4 Skill Development in ESDM Sector
 - 9.7.5 Training on Government Official on e-waste management under 'Digital India'
 - 9.7.6 Synergy through Collaboration & MoUs
 - 9.7.7 Embedded and IoT Ventures
 - 9.7.8 Some Notable Achievements
 - 9.7.9 Training Summary
- 9.8 Software Technology Parks of India (STPI)**
- 9.9 Digital India Corporation (DIC)**
 - 9.9.1 Introduction
 - 9.9.2 Achievements during 2019 - 2020
 - 9.9.2.1 DigiBunai™ - "An Open Source CAD Tool for Weaving"
 - 9.9.2.2 Digital Solutions for the Weavers / Designers and Artisans of NE Region (Mizoram)

- 9.9.2.3 Rural Women Technology Park at Basani, Varanasi
- 9.9.2.4 ICT Intervention for Development & Livelihood Enhancement through Women Self Help Groups (SHGs) in Majhwa block of Mirzapur (a backward district), U.P.
- 9.9.2.5 ICT based capacity building for empowerment in the area of health & livelihood for the women belonging to SC/ST community in Latur district of Maharashtra
- 9.9.2.6 Interactive Information Dissemination System (IIDS)
- 9.9.2.7 “Punarbhava™” (www.punarbhava.in) - Web portal for ‘Divyangjan (Persons with Disabilities)’
- 9.9.2.8 Centralized System for Heart Rate Variability (cHRV) Analysis System
- 9.9.2.9 Visual Speech Training System (VSTS) for children with Hearing Impairment (HI)
- 9.9.2.10 Information Technology Research Academy (ITRA)
- 9.9.2.11 Visvesvaraya PhD Scheme for Electronics & IT

10. Other Matters

304 – 308

- 10.1 Use of Official Language Hindi in official work
- 10.2 RTI Matters
- 10.3 Public Grievances
- 10.4 Information & Documentation Centre (Library)
- 10.5 Parliament Matters
- 10.6 Gender Empowerment / Prevention of sexual harassment of women at work place
- 10.7 Activities undertaken for the benefit of differently abled persons “Punarbhava™” (www.punarbhava.in) - Web portal in disability field
- 10.8 Details related to the Vigilance cases

Appendices (I to III)

309 – 314

- Appendix I Summary of Important Audit Observations
- Appendix II Annual Plan 2020-2021
- Appendix III Employees’ Structure
- Appendix IV List of Abbreviations

Executive Summary

Digital India is a flagship programme of the Government of India designed to transform India into a knowledge economy and digitally empowered society by realizing the full potential of fast-paced technological advancement. The digital interventions have been introduced with the firm resolve to spearhead economic and social transformation with expanded digital access and outreach. To provide momentum to the digital revolution India has embarked on, five strategic pillars have been identified for a technology-empowered 'New India'. These include platform driven **digital services**, robust **digital Infrastructure**, holistic **digital inclusion**, enhanced **digital confidence** and IT Services and Manufacturing driven **digital economy**.

One of the key applications of data is the new-age citizen-centric governance model which necessitates the availability of real-time and seamlessly integrated services across ministries and departments. In this regard, platforms have been a powerful driver to converge, consolidate and universalize services. UMANG has become a model in m-Government services by offering more than 490 services with a core platform that is linked to Aadhaar, PayGov, Rapid Assessment System etc. DigiLocker, a key initiative to actualize paperless governance, has achieved various milestones in this financial year. It has around 3.4 crore registered users and more than 373 crore authentic certificates from 195 organisations. The ease of electronic signature coupled with security of cloud storage has incentivized the fast onboarding of issuer entities like UIDAI, CBSE, Ministry of Road Transport & Highways etc. Other initiatives like the intelligence rule engine on National Scholarship Portal, online appointments on e-Hospital and secure Digital Life Certificates through Jeevan Pramaan have also been instrumental in forwarding India towards accomplishment of the Sustainable Development Goals.

In order to strategically saturate the economic gains from digital payment modes, MeitY has made relentless efforts in the launch of BHIM 2.0 which has higher limits for merchant transactions, referral schemes and multi-lingual digital interface. Under DigiDhan Mission, banks have been given targets for merchant acquisition and digital transactions on citizen touch points. Another groundbreaking intervention has been the Digidhan Mitra Chatbot which is Artificial Intelligence based and provides on-demand data from Digidhan dashboard portal. The resolute efforts made by Government of India to improve public service delivery have helped in realizing the final aim of ONE Government experience.

Keeping in line with MeitY's vision of technology-driven sustainable economic growth, due attention has been accorded to the establishment of a solid and robust digital infrastructure. National Knowledge Network has been formalized as a cutting-edge secured and high-speed digital connectivity backbone for research and educational institutions with 31 Points of Presence (PoPs) in various state capitals. Additionally, NKN connects 4 NDCs (National Data Centre), 31 SDCs (State Data Centre), 31 SWANs (State Wide Area Networks), Ministries, Departments and mission oriented agencies such as Department of S&T, DRDO, Ministry of Earth Sciences, Department of Space, ICAR, MHRD, amongst others. In 2019, ISRO congratulated NKN on successfully supporting the Chandrayaan-2 Mission Critical event over NKN using ISRO-JPL-VRF. Digital India Infoway (National Knowledge Network) along with other initiatives like Hyperscale Data Centres & Cloud and design & development of petaflop supercomputers under National Supercomputing mission have been extremely promising in forming a resilient digital ecosystem on the path to become the global hyperscale data centre hub of the world.

Riding on the exponential gains from the digital space, MeitY is also taking measures to strengthen supply chain by giving impetus to local value-added in the electronic manufacturing sector. With an aspirational slogan to 'expand and export', various incentive schemes like PLI, SPECS, Electronic Manufacturing Clusters (EMCs) and exemption of Basic Custom Duty (BCD) for specific electronic products were implemented to accelerate growth in this sector, higher than the current CAGR of 25% over the last 5 years. These policy measures are also aimed at making India a world-class investment destination in ESDM (Electronics System Design and Manufacturing) sector. Over and above that, Centres of Excellence are being established for Large Area Flexible Electronics, technology for Internal Security and others. New initiatives like Visvesvaraya PhD Scheme for Electronic System Design and Manufacturing [ESDM] and IT/IT Enabled Services [IT/ITeS] have been undertaken to give thrust to the research potential of the scholars. To further foster innovation, MeitY has launched the MeitY Start-up Hub with 1200+ startups and 150+ incubation centres already registered.

To ensure inclusivity of digital-driven economic growth, Government has taken various initiatives in this regard in the form of Digital Villages, Rural BPOs and National Language Translation Mission. Other outreach initiatives like Digital Jagriti at Common Service Centres have been organized to increase awareness about financial inclusion. Moreover, tech-talent is being tapped to make the budding workforce future-ready. Many skill development activities like ISEA Information Security Education and Awareness, IT for masses programme etc. have been implemented under Capacity Building scheme 2.0.

With the recent inculcation of technology in public lives, achieving citizen confidence in security of cyberspace has become the need of the hour. Apart from ensuring the safeguarding of digital sovereignty with MeitY's in-house solutions like Cyber Crisis Management Plan and Indian Cyber Security Stack, programmes like Cyber Surakshit Bharat has been introduced and existing programme modules like CIO programme has been revamped and revised. During the year 2019, 422 types of botnet/malware have been tracked and reported to collaborating ISPs/organisations as against 350 types of botnet/malware infections for 2018. CERT-In and its project 'Cyber Swachhta Kendra' was awarded for "Special Recognition in Cyber Security" in CISO MAG AWARDS INDIA 2019. Other initiatives include National Cyber Security Policy, Notification for Preferential Market Access for Cyber Security Products, Cyber Security and Cyber Forensics in C-DAC and Cyber security in Data centres and cloud services

The Annual Report 2019-20 of MeitY highlights the achievements of Digital India 2.0 with a vision to harness digital technology & foster innovation for inclusive, strong, secure and sustainable Digital Economy. MeitY has been able to actualize the slogan of "Minimum government and maximum governance" with 'low investment and high returns' through multiple platforms like Aadhaar, UPI, GeM, UMANG, GSTN etc. Building on the success of the existing platforms, aggressive adoption of emerging technologies like artificial intelligence, blockchain, internet of things, data analytics, etc. by all ministries and departments across all digital interventions can further help attain exponential economic benefits both for the Government and the citizens of India. However, it is important that the respective Governments, ministries and departments, both Central and State, converge their efforts to harness and reap the true potential and benefits of this generational change of India's digital journey to make India the global leader for digital products, platforms, services and goods.

The report showcases India's position in the digital revolution as a country, generating future pathways, powered by technology that is affordable, developmental and sustainable. It is now incumbent upon all the stakeholders and participants of our government and society to collectively work towards defining this 'tectonic shift' in our digital strategy to harness the opportunity to create economic value add of \$800 Billion by the year 2024 and \$1 Trillion by the year 2025 through right digital interventions.

Chapter 1

Overview : Vision, Mission, Objectives, Structure and Functions of MeitY



1.1 Introduction

Ministry of Electronics and Information Technology (MeitY) is responsible for formulation, implementation and review of national policies in the field of Information Technology, Electronics and Internet (all matters other than licensing of Internet Service Provider).

1.2 Vision

e-Development of India as the engine for transition into a developed nation and an empowered society.

1.3 Mission

To promote e-Governance for empowering citizens, promoting the inclusive and sustainable growth of the Electronics, IT and ITeS industries, enhancing India's role in Internet Governance, adopting a multipronged approach that includes

development of human resources, promoting R&D and innovation, enhancing efficiency through digital services and ensuring a secure cyber space.

1.4 Objectives

1. **e-Government:** Providing e-infrastructure for delivery of e-services
2. **e-Industry:** Promotion of electronics hardware manufacturing and IT-ITeS industry
3. **e-Innovation/R&D:** Implementation of R&D Framework - Enabling creation of Innovation/R&D Infrastructure in emerging areas of ICT&E/Establishment of mechanism for R&D translation
4. **e-Learning:** Providing support for development of e-Skills and Knowledge network
5. **e-Security:** Securing India's cyber space

6. **e-Inclusion:** Promoting the use of ICT for inclusive growth
7. **Internet Governance:** Enhancing India's role in Global Platforms of Internet Governance.

1.5 Functions of Ministry of Electronics and Information Technology (Electroniki Aur Soochana Praudyogiki Mantralaya)*

1. Policy matters relating to information technology; Electronics; and Internet (all matters other than licensing of Internet Service Provider).
2. Promotion of internet, IT and IT enabled services.
 - 2 A. Promotion of Digital Transactions including Digital Payments.**
3. Assistance to other departments in the promotion of E-Governance, E-Commerce, E-Medicine, E-Infrastructure, etc.
4. Promotion of Information Technology education and Information Technology-based education.
5. Matters relating to Cyber Laws, administration of The Information Technology Act, 2000 (21 of 2000) and other IT related laws.
6. Matters relating to promotion and manufacturing of Semiconductor Devices in the country, excluding all matters relating to Semiconductor Complex Limited (SCL), Mohali.**

7. Interaction in IT related matters with international agencies and bodies e.g. Internet for Business Limited (IFB), Institute for Education in Information Society (IBI) and International Code Council – online (ICC).
8. Initiative on bridging the Digital Divide: Matters relating to Digital India Corporation (DIC)****.
9. Promotion of Standardisation, Testing and Quality in IT and standardisation of procedure for IT application and Tasks.
10. Electronics Export and Computer Software Promotion Council (ESC).
11. National Informatics Centre (NIC).
12. Initiatives for development of Hardware/Software industry, including knowledge-based enterprises, measures for promoting IT exports and competitiveness of the industry.
13. All matters relating to personnel under the control of the Ministry*****.
14. Unique Identification Authority of India (UIDAI)*****.

1.6 Organisation Structure:

The Secretariat of the Ministry of Electronics and Information Technology (MeitY) is headed by Secretary, who is assisted by AS and FA, and Group Coordinators and Heads of Organisations under the administrative charge of MeitY. The organisation chart is as follows:-

*. Inserted vide Amendment series no.327 dated 16.07.2016. Earlier (as Department) modified vide Amendment series no.300 dated 26.02.2012

** .Inserted vide Amendment series no. 332 dated 13.02.2017.

***.Inserted vide Amendment series no.279 dated 01.03.2005 and further modified vide series no.322 dated 17.03.2016.

**** Modified vide Amendment series no. 345 dated 17.10.2018.

***** Modified vide Amendment series no.281 dated 01.09.2005, Further modified vide amendment series no.327 dated 16.07.2016.

***** Inserted vide Amendment series no.318 dated 12.09.2015 (Earlier inserted under Planning Commission vide Amendment Series no.296 dated 22.02.2010, and in NITI Aayog vide series no.312)

**MINISTRY OF ELECTRONICS AND INFORMATION TECHNOLOGY (MEITY)
ORGANISATION STRUCTURE**

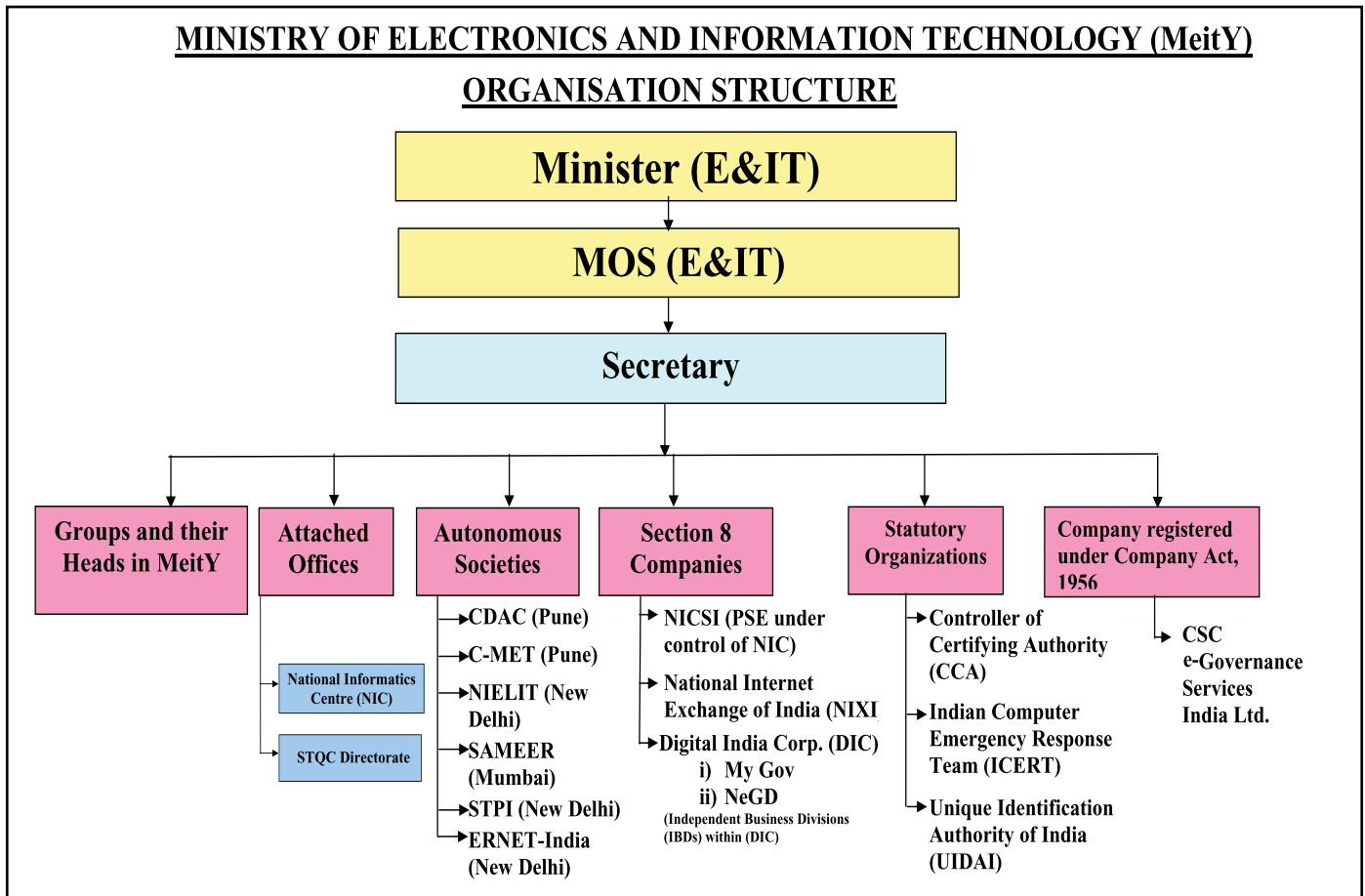

In order to operationalise the objectives of MeitY, schemes are formulated and implemented, either directly or through its Responsibility Centres (Organisations/Institutions) under its jurisdiction. To make the technology robust and state-of-the-art, collaborations with the academia and the private/public sector is also sought. MeitY has two Attached Offices (viz., NIC, STQC), six Autonomous Societies

(viz., CDAC, CMET, NIELIT, SAMEER, STPI and ERNET India), three Section 8 companies [viz., NICS, NIXI and Digital India Corporation (DIC)], three Statutory Organisations (viz., CCA, ICERT and UIDAI) and one Company registered under Companies Act. 1956 (viz., CSC e-Governance Services India Ltd.) under its charge to carry out the business allocated to the Ministry.

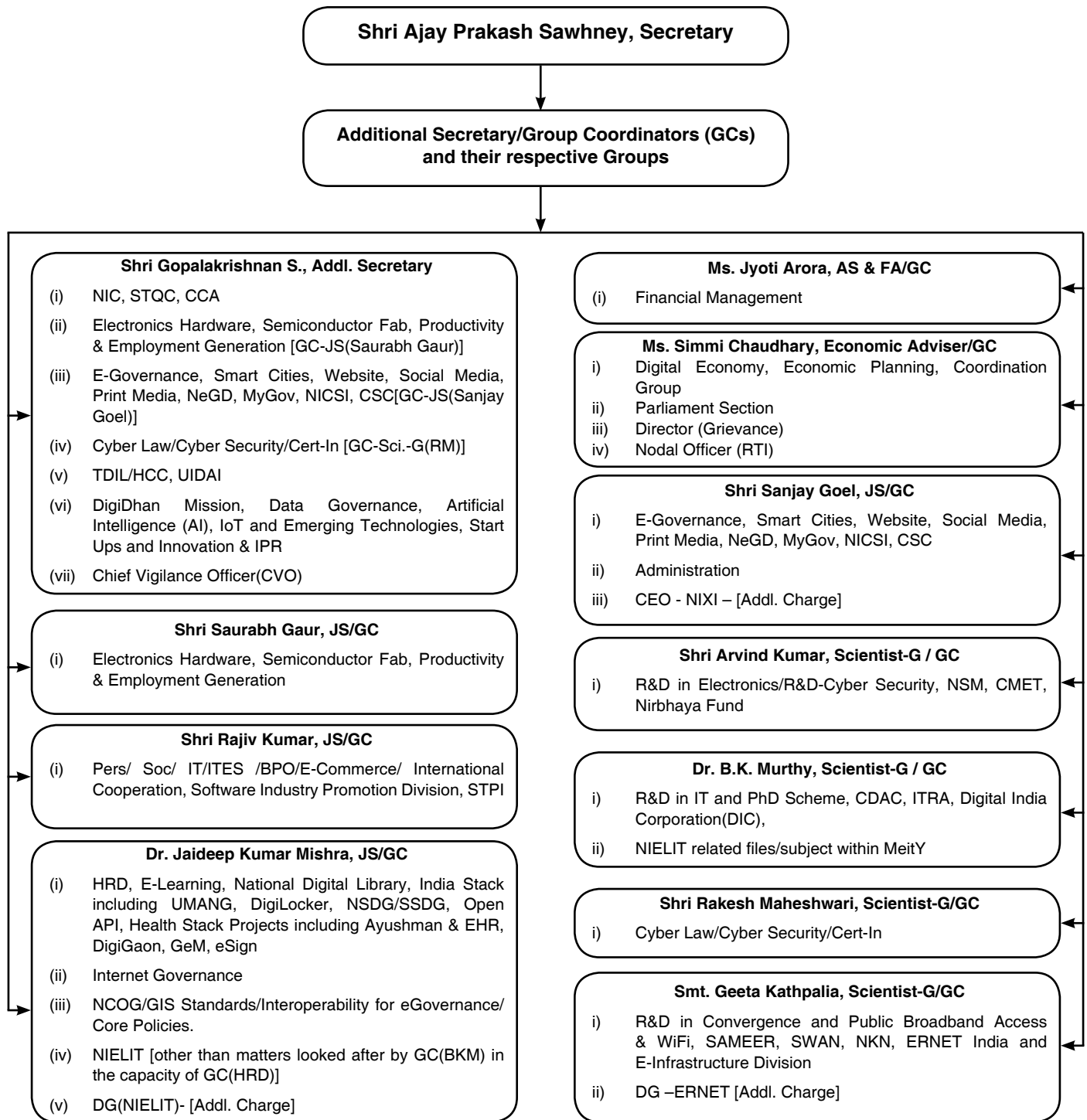

1.7. Client's/Citizens' Charter (CCC)

Details on Client's/Citizens' Charter (CCC) are available on the website of Ministry of Electronics & Information Technology, url: www.meit.gov.in/clients-citizens-charter (as a part of 'About MeitY').

Chapter – 2

Digital India: Power to Empower



Digital India is an umbrella programme to prepare India for a knowledge based transformation. It weaves together a large number of ideas and thoughts into a single comprehensive vision, so that each of them is seen as part of a larger goal. The focus of Digital India programme is on being transformative to realise - IT (Indian Talent) + IT (Information Technology) = IT (India Tomorrow) and making technology central to enable change. This programme pulls together many existing schemes. The Digital India programme is designed to transform India into a knowledge-based economy and a digitally empowered society by ensuring digital services, digital access, bridging the digital divide, digital inclusion and digital empowerment. Such an objective is sought to be achieved with the power of technology that is affordable, developmental and inclusive.

Digital India architecture has transformed governance processes for delivery of services.

Digital India weaves together a large number of ideas and thoughts into a single comprehensive vision to ensure that benefits of development reach each and every citizen of the country in equal measure, along with the need for faster and timely service delivery. This vision is centred on three key areas, namely Infrastructure as Utility to Every Citizen, Governance & Services on Demand and Digital Empowerment of Citizens.

Vision of Digital India: The Digital India programme is centred on three key vision areas:

Vision Area 1: Digital Infrastructure as a Utility to Every Citizen includes:

- Availability of high speed internet as a core utility for delivery of services to citizens
- Providing cradle to grave digital identity that is unique, lifelong, online and authenticable to every citizen

- Mobile phone & bank account, enabling citizen participation in digital & financial space
- Easy access to a Common Services Centres
- Shareable private space on a public cloud
- Safe and secure cyber-space.

Vision Area 2: Governance & Services on Demand includes:

- Seamlessly integrated services across departments or jurisdictions
- Services availability in real time from online & mobile platforms
- All citizen entitlements to be available on the cloud
- Digitally transformed services for improving ease of doing business
- Making financial transactions electronic & cashless
- Leveraging GIS for decision support systems & development

Vision Area 3: Digital Empowerment of Citizens includes:

- Universal digital literacy
- Accessible digital resources universally
- All document/certificates to be available on cloud
- Availability of digital resources/services in Indian languages
- Collaborative digital platforms for participative governance
- Portability of all entitlements through cloud

Pillars of Digital India

This transformational programme has been designed to build holistic capabilities across infrastructure, manufacturing, processes, skill sets and delivery platforms which, in turn, will lead to the

creation of a self-reliant knowledge economy. The focus is on improving direct services to citizens, as well as making the country ready for ease of doing business. Accordingly, the aim is to build and sustain all the associated layers, required for digital empowerment of the people and building a digital economy, through all the initiatives of Digital India programme.

To ensure focus on each of these layers, following nine pillars of growth areas have been identified under the Digital India Programme:

- Broadband Highways
- Universal Access to Mobile Connectivity
- Public Internet Access Programme
- e-Governance – Reforming Government through Technology
- e-Kranti - Electronic Delivery of Services
- Information for all
- Electronics Manufacturing – Target NET ZERO imports
- IT for Jobs
- Early Harvest Programmes

2.1 Digital Infrastructure as a Core Utility to Every Citizen

2.1.1 Digital Identity

Aadhaar: An efficient and targeted Service Delivery Platform

Unique Identification Authority of India (UIDAI) has been mandated to empower every resident of India with a unique identification number and provide a digital platform for authentication in an easy, electronic and cost-effective way.

The Aadhaar system is built on a sound strategy and a strong technology backbone and has now evolved into a vital digital identity infrastructure.

Key features of Aadhaar include:

- 12-digit random unique number for a resident obtained through the process of de-duplication involving biometrics.
- Number does not contain any intelligence.
- Scalable technology architecture
- Open source technologies

Aadhaar, being a unique digital ID, provides a powerful platform for authenticating a resident anytime and anywhere, in line with the vision of the UIDAI. The purpose of authentication is to enable residents to prove their identity and for service providers to confirm that the residents are ‘who they say they are’ in order to supply services and give access to benefits.

2.1.1.1 e-Pramaan: A National Authentication Service

e-Pramaan is a centralised standard based strong multi-factored authentication system, with single sign on (SSO). e-Pramaan provides four factors for user authentication, Password (text, image), One Time Password (SMS, email, mobile app), Digital Certificate (Indian CAs), and Biometric (Finger Print, IRIS) in its production environment. Aadhaar APIs are used for biometric authentication.

Key Features

- Single Sign On (SAML 2.0 based)
- Support in Java, Dotnet, PHP
- Seamless upgrade to new technology

- Two way authentication
- Flexible authentication chaining
- Role based authorisation
- Secured communication channel
- IP based fraud detection and management
- Integration with ID providers like Aadhaar, Driving Licence

Another major component of e-Pramaan is Aadhaar Ecosystem. C-DAC is ASA – AUA/KUA of UIDAI to provide Aadhaar services and is compliant with the latest notifications of UIDAI.

Major Outcome

- 245 Departments integrated with over 9.3 crore Transactions
- A standard was formulated

e-Pramaan – Products

e-Pramaan is also available as a solution and product along with service. Below are the details:

- a) One Time Password (OTP)
- b) e-Pramaan Complete Solution as an Instance for :
 - Customizable Portal specific to State/ Department
 - Independent State / Department’s User directory
 - Autonomy of Infrastructure management by State / Department
 - Inclusion of State Identity Cards



2.1.1.2 Online e-Sign (e-Hastakshar)

One of the initiatives taken under Digital India Programme is to provide non-repudiable authentication of applicant's identity through a facility called e-Sign. e-Sign is an online electronic signature service, which can be integrated with service delivery applications via an Application Programming Interface (API) to facilitate an e-Sign user, to digitally sign a document. Using authentication of the Aadhaar holder through Aadhaar e-KYC service, online electronic signature service is facilitated.

e-Sign service facilitates instant signing of documents online by citizens in a legally acceptable form. The services are being leveraged by various applications such as National Informatics Centre (NIC), Digital Locker, Directorate General of Human Resource Development (DGHR), Department of Panchayati Raj & Rural Development of Andhra Pradesh Government, Uttar Pradesh Forest and Wildlife Deptt, Government agencies for internal office uses.

Notification of Electronic Signature or Electronic Authentication Technique and Procedure Rules, 2015, in which the technique known as 'e-authentication technique, using Aadhaar e-KYC services' for the e-Sign Online Service was introduced, which allows everyone to have the ability to digitally sign electronic documents. Recently, CCA has released e-Sign 3.0 specifications based on Aadhaar offline eKYC, wherein XML is enabling offline mode for obtaining eKYC. This requires one-time registration between e-Sign user and e-Sign Service Provider and supports two factor authentication while e-Signing.

Achievements

- C-DAC's e-Sign Service (e-Hastakshar) enables an Aadhaar holder, with registered mobile number with Aadhaar, to electronically

sign a form/document anytime and anywhere using a device.

- Staging environment of e-Sign 3.0 is released to ASPs in October 2019.
- During the year, C-DAC carried out integration with various Government and private agencies for leveraging e-Sign service at Production level and 96.73 lakh signatures have been generated till 31st December 2019.
- Internal monitoring of service parameters pertaining to applications has been enabled using Dashboard for Client Interface Team.

2.1.2 State Wide Area Network (SWAN)

State Wide Area Network (SWAN) is one of the core infrastructure components of the National e-Governance Plan (NeGP) of Govt. of India. Under the SWAN scheme, it was proposed to establish State Wide Area Networks across the 35 States/UTs so that a common secure IT infrastructure can be created to enable seamless delivery of Government to Government (G2G), Government to Citizen (G2C) and Government to Business (G2B) services.

SWAN envisaged as the Converged Backbone Network for data, voice and video communications throughout a State/UT and has catered to the information communication requirements of various Government departments by extending connectivity up to the block level.

The Scheme for establishing State Wide Area Network (SWAN) across the country was approved to connect all State/UT's Headquarters up to the Block level via District/ sub-Divisional Headquarters, in a vertical hierarchical structure with a minimum bandwidth capacity of 10 Mbps per link. Each of the States/UTs could enhance the bandwidth up to 34-100 Mbps between SHQ and DHQs and upto 8-10 Mbps between DHQs and BHQs depending upon the utilization.

Government Approval for the SWAN scheme in the country with an overall outlay of Rs. 3,334 crore, (MeitY's Grant-In-Aid component being Rs.2005 crore and ACA components Rs.1329 crore) was to be expanded in five years. To facilitate smooth and time bound implementation, policy guidelines were formulated, addressing various issues related to planning and implementation of the SWAN scheme, including roles and responsibilities of different agencies/stakeholders.

Presently, SWAN has been made operational in 34 States/UTs. The States/UTs are utilising the core infrastructure of SWAN for providing the Closed User Group (CUG) connectivity to various Government offices in the State/UTs. These offices access their applications through SWAN in secured environment hosted at State Data Centres (SDCs).

The States have been utilising the core infrastructure of SWAN for connectivity and dedicated close user application access connectivity. SWAN has been integrated with NKN in 29 States/UTs at SHQ level and 540 Districts at the DHQ level to provide the high bandwidth.

Increasing digitisation amongst states has led to higher utilization of bandwidth. Presently, 30 States/UTs are utilizing around 70-72 % of bandwidth of the existing link capacity. To monitor the performance of SWANs, the Ministry has mandated positioning of Third Party Auditors (TPAs) in the States/UTs. Till 31st December 2019, 29 States have empanelled the TPAs for monitoring the performance of the SWAN in the respective States/UTs.

2.1.3 State Data Centre (SDC)

State Data Centre (SDC) is one of the three core infrastructure components under the NeGP. Under the SDC scheme, Data Centres to be established in all the States/UTs to consolidate services, applications and infrastructure in order to provide efficient electronic delivery of Government to Government (G2G), Government to Citizen (G2C)

and Government to Business (G2B) services. These services can be rendered by the States through common service delivery platforms seamlessly supported by core connectivity infrastructure, such as, SWAN and CSCs as the front-end delivery outlets at the village level. Some of the key functionalities that can be provided through SDC are central repository for the State, secure data storage, online delivery of services, citizen information/services portal, State Intranet Portal, disaster recovery, remote management and service integration, etc. SDCs also provide better operation and management control with minimized overall cost of data management, IT resource management, deployment and other costs for States/UTs.

As on 31st Dec 2019, 29 SDCs have been declared operational in Tamil Nadu, Puducherry, West Bengal, Andhra Pradesh, Meghalaya, Goa, Karnataka, Manipur, Odisha, Sikkim, Haryana, Kerala, Maharashtra, Gujarat, Tripura, Rajasthan, Nagaland, Uttar Pradesh, Andaman and Nicobar Islands, Madhya Pradesh, Lakshadweep, Chhattisgarh, Jammu and Kashmir, Mizoram, Bihar, Himachal Pradesh, Jharkhand, Punjab, Uttarakhand.

Out of the 3 pending SDCs (yet to be operational) Assam has been selected as Data Centre Operator (DCO) and all Centres have started installation.

Since the SDCs are expected to host critical Government applications/services including important citizen data, protection of the same is of prime importance. In this regard, the SDC scheme has provisioned for a Disaster Recovery (DR) mechanism through storage based replication, as part of the SDC enhancement. 17 States have been DR enabled.

MeitY is providing continuous support and guidance to the States/UTs in order to ensure smooth implementation of the project across the country.

Policy guidelines, roles and responsibilities of different agencies/ stakeholders, including various issues/concerns to be addressed while planning, implementation operations and maintenance of the Data Centres have been formulated. Guidelines are updated from time to time and are communicated to the States/UTs, leading to creation of consistent and state of art infrastructure.

Achievements

- In FY 2019-20, Uttarakhand SDC became operational and Assam SDC is under implementation.
- 3 State Data Centres (Mizoram, Nagaland, A&N) would be completing 5 years of operations during the year 2019-20.

2.1.4 GI Cloud (MeghRaj)

In order to realize the Digital India vision, and to utilize and harness the benefits of Cloud Computing, the Government of India has embarked upon an ambitious initiative – “GI Cloud”, which has been named as ‘MeghRaj’. MeghRaj initiative is intended to deliver ICT services over cloud to all the Departments/Ministries at the Centre and States/UTs. The vision of this initiative is to accelerate delivery of e-Services in the country, while optimizing ICT spending of the Government. As per the MeghRaj policy, “Government departments at the Centre and States to first evaluate the option of using the GI Cloud for implementation of all new projects funded by the Government. Existing applications, services and projects are being included to assess whether they should migrate to the GI Cloud”.

Some of the major benefits of GI Cloud are listed below:

- Driving cost efficiencies with increased utilization of IT Infrastructure resources through cloud.
- Enable conversion of CAPEX to OPEX paving the way for consumption based billing

and faster procurement of IT Infrastructure services.

- Rapid development, deployment and re-use of ICT applications.
- On demand scalability of infrastructure to meet the long-term capacity requirements and elasticity to cater to the peak load requirements. The major components of MeghRaj include:
 - o Setting up of State and National Clouds
 - o Setting up of an e-Gov Appstore
 - o Empanelment of Cloud Service Providers
 - o Empanelment of Cloud Auditors
 - o Setting up of Cloud Management Office (Policies, Guidelines, templates, security norms, certification, etc.)
 - o Awareness workshops, training programmes and migration support for cloud adoption by Departments
 - o MeghRaj (GI-Cloud) service Directory
 - o Setting up of Clouds by other Government entities

Achievements

The first National Cloud implemented by NIC is already being used by more than 1115 applications of Government Departments. NIC Cloud can be accessed using the following link: <https://cloud.gov.in/>

Initiatives under Digital India Program hosted on National Cloud include:

- Digital India Portal
- Digital Locker
- Digitize India
- Make-in-India
- Skill Development
- Smart Cities

- Online Registration System (e-Hospital)
- Aadhaar based Biometric Attendance of Government employees
- Jeevan Pramaan - service for pensioners
- MyGov - largest citizen engagement platform of the Government

The e-Gov Appstore under GI Cloud can be accessed using the link <http://apps.gov.in/>.

MeitY has empaneled 12 Cloud Service Providers (CSPs) for a variety of Cloud deployment models (Public Cloud, Virtual Private Cloud, and Government Community Cloud) and Cloud Service offerings (IaaS, PaaS & SaaS). The empaneled CSPs are Microsoft Corporation (India) Private Limited, Tata Communications Limited, Bharat Sanchar Nigam Limited (BSNL), ESDS Software Solutions Private Limited, Net Magic IT Services Private Limited, Sify Technologies Limited, CtrlS Data Centre Limited, Cyfuture India Private Limited, Web Werks India Private Limited, AMAZON Internet Services Pvt. Limited, NXTRA Data Limited and Reliance Corporate IT Park Ltd. The current status of the audit and the contact details of the empanelled CSPs can be accessed using the link <http://MeitY.gov.in/content/gi-cloud-meghraj>.

2.1.5 Service Delivery Gateway

Government services should be seamlessly integrated across departments or jurisdictions to provide easy and a single window access to all citizens. It will reduce the time and efforts involved in various approvals, clearances, etc. It would also ensure transparency in the system. In order to meet the objective of seamless integration across the departments, architecture of the application should be designed in a way that interfaces with other systems may be built whenever required.

e-Sangam: National Service Delivery Gateway (NSDG) is Service Oriented Architecture (SOA) based constellation of National and State

e-Governance Service Delivery Gateways, with an objective to provide a standardized interfacing and seamless message exchange among various Government portals as front-end service access providers, back-end service providing departments and domain gateways. e-Sangam enables seamless integration of department applications and provides a framework for single point delivery of e-Governance services of services delivered by heterogeneous departments.

Achievements

- 507 services registered in the production environment of NSDG;
- UMANG integration with e-Sangam for UT of J&K services completed;
- Average monthly transaction for the year 2019: 7.9 lakh.

2.1.6 National Knowledge Network (NKN)

National Knowledge Network (NKN) is an innovative cutting-edge secured & resilient network, which provides a centralized high-speed digital connectivity backbone for research & education institutions and Government Organisations spread across India.

NKN was approved in March, 2010 by Government of India with National Informatics Centre (NIC) as the implementing agency. Aligned with its objective since its approval, NKN has been progressively interconnecting all institutions of higher learning and research with high-speed network in order to create a backbone ecosystem for knowledge sharing and collaborative research.

NKN with its design philosophy to Encourage, Enable, Enrich and Empower the user community is enabling and empowering the implementation of “Digital India” by supporting and providing connectivity to various endeavours of the Government of India in the field of e-Governance.

NKN Growth and Status

NKN since its inception, has been progressively growing its footprints at National and International frontiers to ensure that Indian Research and Education community excel in their endeavours and also get international and global collaboration with their peers across the globe.

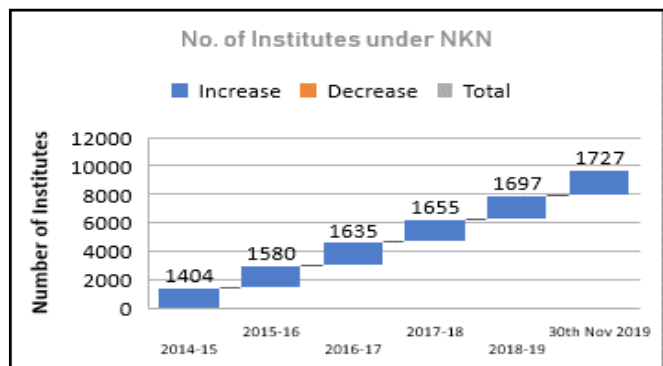

NKN is the one of the largest network of its kind in the world and is currently perceived as a leading research and education network (REN) globally.

NKN Status: National Reach

- Under NKN, 1727 links to institutions have been commissioned and made operational. This includes 389 links to institutions under NMEICT, which have been migrated to NKN. It also comprises of almost all the major IITs, Central Universities, State Universities, NITs, IIITs, IIMs, hospitals in tertiary care such as AIIMS, PGIs, State Government hospitals, national laboratories under DAE & DST, DRDO, MHRD, ICAR, ICMR and a host of other Government institutions / departments.
- The outreach includes 515 District links covering 467 Districts connected under NKN across the country.
- Today NKN has 31 Points of Presence (PoPs) in various State Capitals (including 7 Super Core PoPs).
- The network strength of NKN comprises of high speed (10G) core backbone with

uniformly spread 94 core links across the country.

- In its progressive outreach, NKN has provided 10G links to 29 institutes.
- High Capacity SCPC VSAT Connectivity at Kavarati, Lakshadweep and Port Blair, Andaman & Nicobar Island are also provided.

NKN Status: International Reach

- NKN has been significantly expanding its global reach by establishing **3 International PoPs** at Singapore, Amsterdam and Geneva (CERN).
- For increasing its Global outreach, NKN has peered with other National Research and Education Networks (NRENs) such as Asi@connect in Asia Pacific, CERN and GEANT in Europe, SingAREN in Singapore, Internet2 in USA, LEARN in Sri Lanka, BdREN in Bangladesh, DrukREN in Bhutan and NORDUnet for Nordic countries.

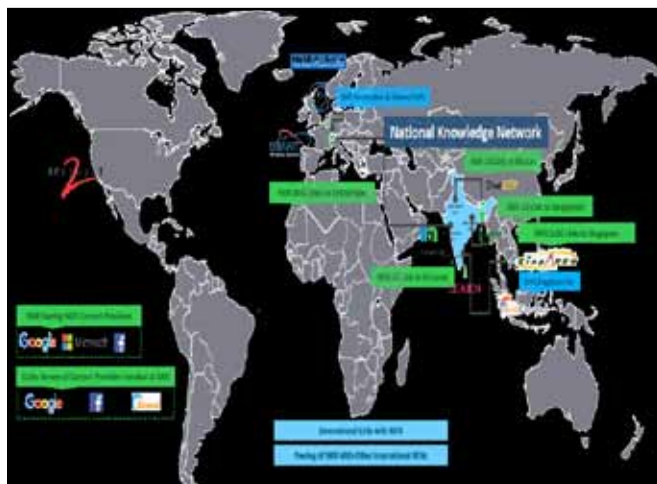

- NKN is under process for expanding its links in SAARC and BIMSTEC Nations; As per the vision of Hon'ble Prime Minister of India, to bolster sub-regional collaboration among SAARC and BIMSTEC countries, NKN has already extended its connectivity to Sri Lanka (LEARN), Bhutan and Bangladesh. It is also in the process of extending its connectivity with the RENs of Nepal, Afghanistan and Maldives.

Achievements

Facilitating Digital India

NKN facilitates Digital India, as it is the backbone for all e-Governance initiatives in the country. In addition to educational Institutes, NKN connects 4 NDCs (National Data Centre), 31 SDCs (State Data Centre), 31 SWAN (State Wide Area Networks), Ministries, Departments and mission oriented agencies such as; S&T, DRDO, Earth Sciences, Space, ICAR, MHRD, amongst others.

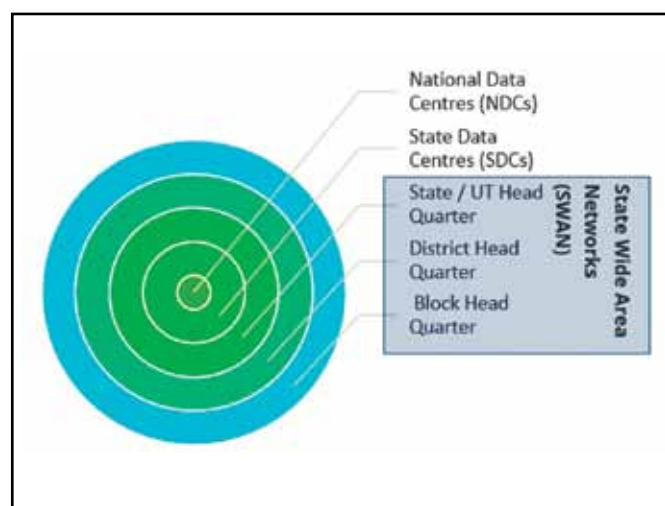

Connecting Remote Locations

- **Connectivity in North East Region:** NKN has ensured stable connectivity in the north-eastern region by connecting major institutions and enabling Digital Inclusion in the region.
- **VSAT Connectivity in remote locations:** NKN has successfully established a High Capacity SCPC VSAT Connectivity at Kavarati, Lakshadweep and Port Blair, Andaman & Nicobar Island.
- **Connectivity in Jammu & Kashmir (J&K) and Ladakh:** NKN has extended its connectivity to some of the major institute of J&K and Ladakh such as IIT Jammu, IIM Jammu, University of Jammu, Sher E Kashmir, Defence Institute of High Altitude Research (DIHAR) Leh etc.

Incessant Network

To ensure high accessibility, availability & sustainability, NKN has focused on dedicated high bandwidth with low latency and redundancy.

- In order to optimise bandwidth utilization, NKN has brought the content close to the users, via direct peering and caching with leading Content Providers such as Google, Microsoft, Facebook and Akamai.
- The peering has been done via servers installed at the premises of NKN in order to ensure enhanced user experience. With the aid of NKN, Near Real Time Data availability is provided along with Service Continuity with High Uptime.



- NKN provides Direct Connectivity to Institutes/Organisations by taking the best path via minimum hops. Hence, due to this quality of services, connected Institutes have given NKN a rating of excellent on all quality of service parameters.

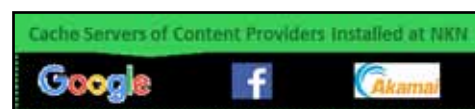

Secure Network

NKN's security eco-system is balanced, robust and provides a resilient backbone network for its user community that can recover quickly from breakdowns and other cyber-attacks.

- Vulnerability Assessment and safe guarding of the network is performed regularly via multiple tools e.g. DDOS Implementation etc.
- NKN is ISO 27001 certified that ensures the right processes for the robustness of the network and applications.

- For time synchronisation, NKN has implemented Network Time Protocol (NTP) which is an Internet time synchronisation protocol, used to synchronise computer clocks to a time reference using the IP network/ internet.
- NKN currently provides multiple free of cost services to the Institutes like Single Sign On (SSO), DDOS, E-mail services, DNS, LDAP, etc.

Bolstering Knowledge Society

NKN has been a key backbone for Research, e-Governance, e-learning and collaboration usage in the fields of education, health, agriculture, science, space and weather etc.

- NKN plays a vital role in resolving the pollution crisis. NKN comprising of IITs (Delhi, Kanpur, Chennai, Mumbai, Roorkee, Guwahati, Hyderabad and Tirupati) and other institutes (PGI Chandigarh and Bose Institute Kolkata) will support and act as a knowledge partner to the national clean air program (NCAP) which aims to reduce air pollution by 20-30 percent in the next five years.
- NKN has implemented 66 Virtual Classroom as part of its e-Learning service. Educational institutes on NKN are connected through studio and web-based video conferencing services.
- By Connecting National Digital Library (NDL) through NKN, the network ensured that every institute of higher learning had access to NDL. It has on boarded 35 lakh users so far.
- In the field of education NKN has been used as a backbone for pan India delivery of NPTEL videos, Knowledge Management Centres (KMC at National Institutes of Design) database accessibility, Training 10 Thousand Teachers (T10KT).

- In the field of health NKN has helped Open Source Drug Discovery (OSDD), Collaborative Digital Diagnosis System, Cancer Grid, Knowledge and Healthcare Delivery Network in SGPGI and in Telemedicine.
- India's efforts in Space & Weather Research has been further enhanced by connecting to NKN. Some of the notable mentions are GARUDA, Indian Space Science Data Centre - Mission Mars, Chandryaan-2.
- In the area of weather forecasting, NKN has supported in establishing "EUMETSAT Terrestrial Broadcasting Reception" at ISRO for receiving EUMETSAT data on real time basis. It has helped in setting a secure network for receiving database from NOAA-NESDIS (USA), which helped immensely in accurate weather forecasting and analysis

"ISRO Congratulated NKN on successfully supporting the Chandryaan-2 Mission Critical event over NKN using ISRO-JPL-VRF.

Also, extended heartfelt gratitude to entire NKN Team for "proactively taking up this activity and supporting us during the entire period"

2.1.7 Mobile Seva Platform

MeitY has initiated a massive countrywide initiative on mobile governance, being implemented by C-DAC Mumbai, to provide Government services to the people through mobile phones and tablets. As a part of this initiative, the Framework for Mobile Governance was notified in February 2012. Mobile Seva has been developed by MeitY as the core infrastructure for all Government departments and agencies in the country for enabling the availability of public services through mobile devices.

Mobile Seva enables the integration of the mobile platform with the common e-Governance

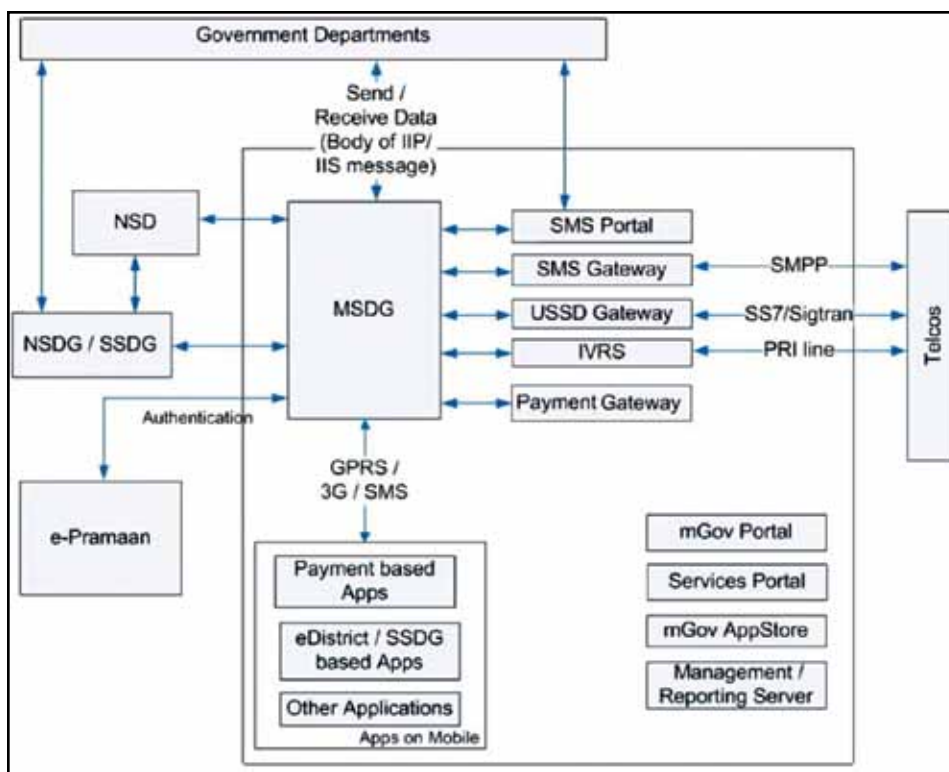

Mobile Seva Platform

infrastructure consisting of SDCs, SWAN and SSDG/NSDG. It enables a Government department to integrate both web and mobile based services seamlessly and enhances the access to electronic services tremendously due to the very high penetration of mobile phones, especially in rural areas.

It provides all possible mobile based channels for delivering services, such as SMS, USSD, IVRS and mobile applications (m-Apps). Availability of Government wide shared infrastructure and services enable rapid development and reduced costs for the departments in rolling out electronic services.

Achievements

- 4,401 Government departments and agencies integrated with the Mobile Seva platform.
- 3,005 crore PUSH SMS were delivered.
- 697 services are available to citizens and businesses over Pull SMS.

- 988 live m-apps have been developed and hosted on Mobile Seva Appstore for different platforms. 7.7 crore downloads of different apps have been done.
- 1.30 crore transactions in IVRS Services and over 17.59 lakh transactions in USSD Service have been completed.
- Mobile Seva project of C-DAC, Mumbai has been selected as one among 41 Gems of Digital India 2017 (Analyst’s Choice) for excellence in eGovernance.
- Mobile Seva Project is a winner for showing Excellence in Designing the Future of eGovernment at Global mobileGov World Summit May, 2017.

2.1.8 Geographical Information System (GIS)

The Geographic Information System (GIS) based decision support system (DSS) platform was established under the National Centre of Geo-

Informatics (NCoG) which was approved on 31st December 2015 with an outlay of Rs. 98.28 crore.

Some of the key features of NCoG based applications include:

- Base map available at 1:5,000 scale
- Compatibility of multi-purpose geo-datasets
- Allows user to plot assets/features on their own
- Self-sustainable
- Cost effective
- Based on Open-Source (no software procured)

The platform is a single source GIS platform for sharing, collaboration, location-based analytics and decision support system, catering to Central and State Government departments across the country. The GIS platform has provision to integrate with MIS data of Ministries/Departments. It is developed by NeGD in collaboration with Bhaskaracharya Institute for Space Applications and Geo-Informatics (BISAG).

The following GIS applications have been developed/under implementation:

- i. Government Land Bank Information System Ministry of Housing and Urban Affairs (MoH&UA): Map all Central Government land parcels, including that of Central Public Sector Enterprises (CPSEs).
- ii. Rural Electrification System (Ministry of Power): Identify and map electrification status of villages under Grameen Vidyutikaran App (GARV).
- iii. Mining Surveillance System (Ministry of Mines): Curb illegal mining through automatic remote sensing detection.
- iv. Industrial Information System (DIPP): GIS based master plan for industrial areas, zones, parks etc.

- v. Geographic Indications Web Portal – A web portal to promote and undertake GIS mapping of Geographic Indications under the Department of Industrial Policy and Promotion.
- vi. Saltpan Information System (DIPP): Central departments may view details of saltpan area/ land at cadastre level across India with details, such as, survey numbers, litigations etc. The departments can then apply to DIPP for buying the land parcels concerned.
- vii. Coal Mining Surveillance System (Ministry of Coal) – System for surveillance and monitoring of any illegal coal mining activity taking place in the coalfield region.
- viii. Textile Mills Information System : Plot all mills of National Textile Corporation Limited (NTCL) to facilitate identification of illegal encroachment.
- ix. e-District services with CSC locations (MeitY): Pilot CSC locations and e-District services available across India.
- x. Digital India outreach (MeitY): To represent live status of Digital India outreach vans.
- xi. GIS for North-Eastern States (Ministry of Development of North Eastern Region): asset mapping of North East region.
- xii. Road Information System (Ministry of Road, Transport & Highways): Geo-mapping present status of lanes, impedances of national highways, state highways etc.
- xiii. Delhi Police GIS system and Mobile App for Dark Spot Area (Ministry of Home Affairs): Web/mobile based application to represent operational status of light poles and dark areas in Delhi.
- xiv. Mapping of water resources under Accelerated Irrigation Benefits Programme and Repair, Renovation and Restoration of Water Bodies Ministry of Water Resources, River Development & Ganga Rejuvenation (MoWR,RD&GR).

- xv. GIS system for NHAI: Plot national highways along with advanced analytics for basic details, construction progress matrix, land status, clearance status, commercial operations, focus projects.
- xvi. AMRUT/Smart Cities, MoH&UA – To provide a facility to map assets/amenities and facilitate developmental planning under AMRUT scheme.
- xvii. Soil Information System - Integration of Soil Health Card with NBSS&LUP soil survey data (Ministry of Agriculture) to represent soil information on GIS platform including crop recommendations.
- xviii. Mapping of mortgaged land assets of companies (Ministry of Corporate Affairs) – GIS based application to represent.
- xix. Logistics Information System (Ministry of Commerce and Industry)
- xx. Training Institute Mapping - Department of Personnel & Training (DoPT)
- xxi. Electronic Manufacturing Units Mapping – MeitY
- xxii. Central Board of Secondary Education (CBSE) applications
 - o GIS based location capture for new school applicants
 - o Plot existing school affiliated with CBSE
 - o Mobile app for students to find shortest route to their exam centres
 - o Capture location of the schools who are to apply as proposed exam centres
 - o Distance analysis of exam centres vs school location (with buffer of 5/10/15 Km)
- xxiii. Decision Support System for AICTE, Ministry of Human Resource Development (MHRD): Technical colleges may share their locational details alongwith videos for AICTE approval (Pilot).
- xxiv. Panchayats Extension to Scheduled Areas – PESA, Ministry of Panchayati Raj (MoPR): Visualization of PESA districts on GIS map
- xxv. National Asset Directory, Ministry of Panchayati Raj (MoPR) – Mapping of assets at panchayat level (Pilot)
- xxvi. Capacity building of Town and Country Planning Organisation (TCPO) under Ministry of Housing and Urban Affairs (MoH & UA) in GIS domain.
- xxvii. GIS bases applications for States, such as, Telangana, Haryana, Kerala, Uttarakhand, Uttar Pradesh, Andaman and Nicobar Islands and Tripura.
- xxviii. GIS based system to monitor progress under 115 Aspirational Districts (NITI Aayog): Under this project, respective GIS portals for 65 districts have been made operational.
- xxix. More than 514 GIS applications including 40+ mobile applications across 27 Central Ministries/Department/Agencies & 19 States/UTs have been implemented under NCoG project.

NCoG is also working on the following new projects:

- Social Benefits Management System – A web portal for loan management, disbursement and recovery. GIS support for monitoring of loan recovery – Design and Development phase.
- Industrial Performance Monitoring System– A web portal for Ministry of Statistics and Programme Implementation and 11 other Ministries to use this portal to report data of their industrial sector – Design phase.
- A dashboard to manage Technology and Innovation Support Centre to capture R&D

Activities is also being created for Department of Industrial Policy and Promotion.

- Delhi Police – ‘Design, development, amalgamation and maintenance of ‘Delhi Police... One Touch Away’ – a citizen centric app with 26 services provided by Delhi Police through the previous apps or Web applications.
- Ayushman Bharat, Ministry of Health and Family Welfare (MoH&FW): Infrastructure and disease level mapping of health facilities, including primary, secondary and tertiary care and identification of gaps therein to plan for new health and wellness centres establishment.
- Implementation of National Mission on Cultural Mapping (Ministry of Culture).

2.1.9 High Speed Broadband Connectivity

Provisioning of internet connectivity in rural areas is under the purview of Department of Telecommunications (DoT), under Ministry of Communications. High speed broadband connectivity would be made available upto all 2.5 lakh Gram Panchayats in the country under NOFN/BharatNet programme being implemented by Department of Telecommunications. With the availability of high speed broadband connectivity upto Gram Panchayats, it would be easier for the central and State Governments to deliver various G2B, G2G and G2C services to the citizens across the county. So far, 4,01,478 Kms of optical fiber has been laid 1,45,101 Gram Panchayats and 1,32,632 Gram Panchayats are service ready.

Availability of robust connectivity in turn would make it feasible to plan and deliver other social sector services like e-Health, e-Education, e-Agriculture, Skill development and also financial inclusion. It is envisaged that it would be possible in the near future under the Digital India Programme to have inter and intra state socio economic development in the country.

2.1.10 Public Internet Access Programme (including Wi-Fi in Universities)

Wi-Fi Enabled Campus Network in Five Universities

For achieving Vision of Digital India, ERNET India has setup Wi-Fi enabled campus Network at following universities :

- Allahabad University, Allahabad, U.P.
- Savitribai Phule Pune University (SPPU), Pune, Maharashtra
- North-Easter Hill University (NEHU), Shillong, Meghalaya
- Osmania University, Hyderabad, Telangana
- Utkal University, Bhubaneswar, Odisha.

The Wi-Fi project is installed, commissioned & made operational at all the above 5 Universities. Phase-2 implementation of Utkal University project is under process to cover the remaining locations/ areas under Wi-Fi.

It provides high speed wireless access to Internet/ Intranet resources on any-time any-where basis across the campus. Students/staff are benefitted largely from it. They are accessing e-Books, E-journals from UGC-Infonet, Video Lectures, Online study material, Digital Repository and sharing their information and knowledge among users. It improved performance and efficiency. It enhanced user’s participation where user from all parts of the world are collaborating & sharing information/data for research & development and education.

It provided freedom of work on the move, easy access to the information, increase in productivity and reduction in day to day cost.



eduroam services-Global Wi-Fi roaming services

Eduroam stands for **education roaming services**. It is a secure, world-wide roaming access service developed for the research and education community. It allows students, researchers and

staff from participating institutions to obtain Internet connectivity across campus and when visiting other participating institutions. ‘eduroam’ service is available in 101 territories worldwide.

ERNET India is a National Roaming Operator for providing eduroam services in India. This eduroam facility has been successfully availed by Indian and foreign participants in the universities/institutions. Academic and Research Institutions including IITs, IIMs, NITs, Central and State Universities and various other renowned institutions have benefited from these services. For more details: <http://www.eduroam.ernet.in>



eduroam worldwide presence

2.2 Governance and Services on Demand

2.2.1 e-District Mission Mode Projects

eDistrict is a Mission Mode Project (MMP) that aims at electronic delivery of identified high volume citizen centric services at the District or Sub-District level. Ministry of Electronics and Information Technology (MeitY), Government of India (GoI) is the nodal Ministry for e-District MMP. This MMP is being implemented by State Governments/UT Administrations through their designated agencies. The MMP envisages leveraging and utilizing the four pillars of e-infrastructure, namely, State Data Centre (SDC), State Wide Area Network (SWAN), State Service Delivery Gateway (SSDG) and Common Services Centre (CSC). The objectives of the e-District project are to ensure end-to-end workflow, to ensure delivery of e-Services by undertaking Business Process Re-engineering (BPR) of services and providing easy, anywhere

and anytime access to Government services.

Intended Benefits/Outcomes: The project intends to achieve the following benefits/outcomes:

- Assured, reliable and efficient delivery of high-volume citizen services, electronically and with process reengineering at the District level in all the districts of the country
- Faster service fulfillment for the citizens
- Citizens save time and money
- Modernization of District Administration with training and capacity building at all levels
- Transparency and Good Governance resulting in empowerment of citizens

Coverage and Services under eDistrict MMP

The eDistrict MMP currently covers all Districts across all 36 States/UTs. Under the scheme, MeitY is funding the State Designated Agencies (SDAs) of each States/UTs for implementation of the project over a period of 4 years. 10 categories (5 mandatory + 5 States/UTs Specific) of identified high volume citizen centric public services at District and Sub-District level will be taken up to be electronically delivered under this project.

Services launch Status: As on 30th September, 2019 eDistrict services have been launched in 685 districts across 32 States/UTs. The status is indicated in the table below:

National Roll-out Status of e-District MMP
1. Andhra Pradesh (13/13)
2. Arunachal Pradesh (23/23)
3. Assam (33/33)
4. Bihar (38/38)
5. Chandigarh (1/1)

6. Chhattisgarh (27/27)
7. Dadra & Nagar Haveli(1/1)
8. Delhi (11/11)
9. Goa (2/2)
10. Gujarat (33/33)
11. Haryana (22/22)
12. Himachal Pradesh (12/12)
13. Jharkhand (24/24)
14. Karnataka (30/30)
15. Kerala (14/14)
16. Madhya Pradesh (51/51)
17. Maharashtra (35/36)
18. Manipur (16/16)
19. Meghalaya (11/11)
20. Mizoram (8/8)
21. Nagaland (11/11)
22. Odisha (30/30)
23. Puducherry (4/4)
24. Punjab (22/22)
25. Rajasthan(33/33)
26. Sikkim(4/4)
27. Tamil Nadu (32/32)
28. Telangana (31/31)
29. Tripura (8/8)
30. Uttar Pradesh(75/75)
31. Uttarakhand (13/13)
32. West Bengal (18/23)

Achievements

- Formation of District e-Governance Societies (DeGS) completed in all 36 States/UTs (100% covered in 30 States/UTs and partially completed in 6 States/UTs; due to newly created districts).
- Selection of eDistrict Managers (eDMs) completed in all 36 States/UTs (100% selected in 32 States/UTs, partially selected in 2 States/UTs, due to newly created districts and process initiated in 2 States/UTs, where the roll-out is in process).
- UT of J&K is in the process of engaging NIC for gap analysis, identification of e-Services in consultation with line departments, M/s CSC–SPV for the development of 10 identified e-services under e-District Service Portfolio. Further, Andaman & Nicobar Islands and Lakshadweep have opted for NIC’s ServicePlus platform for final roll-out of project.
- Issuance of following Guidelines/Advisories have been completed:
 - o National Rollout Guidelines
 - o e-District Manager Hiring Guidelines
 - o Guidelines for Integrated Framework for the Delivery of e-services under National Roll-out of e-District MMP
 - o Implementation Guideline for providing flexibility to States/UTs for the implementation of National Roll-out.
 - o Guidelines for Horizontal Connectivity
 - o Draft Agreement Template for States/ UT opting NIC as the Implementation Agency for e-District MMP
 - o Report on “Business Process Re-engineering of High-volume Government to Citizen Services”.

- o Advisory on Operational Expenses of e-District Manager
- o Advisory on Implementing Ration Card services under e-District MMP
- o Advisory on Implementing Birth and Death services under e-District MMP
- o Guidelines for using Hand-held devices for e-District Services.

2.2.2 All Services through Online & Mobile

Unified Mobile Application for New-Age Governance (UMANG): UMANG has been developed as a single mobile platform to deliver major Government services. Hon'ble Prime Minister has dedicated UMANG to the nation on 23rd November, 2017.

- UMANG has been developed as a single mobile platform to deliver major Government services with Core Platform integrated with Aadhaar, DigiLocker, PayGov, Rapid Assessment System (RAS) etc.
- Citizens can access pan India Government services from the Central Government, State Governments, local bodies and their agencies and some important utility services from corporate.
- UMANG supports 12 Indian languages, in addition to English and has been hosted on cloud. UMANG aims to bring power to the finger tips of citizens.
- Till 31st December, 2019, UMANG has about 490 services from 93 applications of Central Government departments and Government departments of 21 States/UTs and many more are continuously being on-boarded.
- UMANG has won awards, namely, the 'Best m-Government Service Award' during the 6th edition of the World Government Summit at Dubai, UAE (February, 2018) and the IDC Digital Transformation Award 2018 under the

category Omni-Experience Innovator (August, 2018) and Special Jury Choice Award in the category of "Excellence in providing Citizen-Centric Delivery" during National e-Governance Awards 2018-19 in February 2019.

2.2.2.1 Programme on Good Governance and Best Practices

This scheme has been initiated to promote Information and Communication Technology (ICT) enabled good governance in the country. Under this scheme, MeitY has finalized a scheme to promote e-Governance in the country, wherein, the replication of successful e-Governance practices and applications would be taken up and departments would also be encouraged to come up with new applications in uncovered domains. Under this scheme, project proposals were sought (from Central/ State/UTs Government departments) which will be funded after due assessment, depending upon the merit of the project.

Achievements: 5 projects have been approved under the scheme and successfully implemented.

2.2.2.2 World Bank assisted "India: e-Delivery of Public Services" Project

Following approval of a Development Policy Loan amounting to US\$ 150 million from the World Bank for programme management and financial support for National e-Governance Plan (NeGP), MeitY has been utilizing this support as a focal point to convene all the associated departments of the central and state governments around a concrete reform agenda for e-governance in the country. MeitY is supporting critical policy and institutional actions of the Central/State/UT government(s) that entail e-delivery of services leading to more robust implementation of NeGP, with significant social benefits for the population and positive impacts on the poor. As on 28.11.2019, a total of 40 projects have been approved.

Achievements: 24 projects covering various domains such as health, education, legislature, prison, election commission and capacity building have been successfully implemented under the scheme and other projects are at different stages of implementation.

2.2.2.3 National Scholarships Portal (NSP)

National Scholarships Portal is an initiative envisaged to be a single unified portal for online scholarship application submission, verification and final disbursement of scholarships amount directly into a student's bank account. This system brings transparency by avoiding duplication and ensures timely disbursement. It aims at providing a Simplified, Mission-oriented, Accountable, Responsive and Transparent ('SMART') System for faster and effective disposal of scholarships applications and delivery of funds directly into beneficiaries account without any leakages by providing common electronic portal for implementing various scholarships schemes launched by the Union Government, State Governments and Union Territories across the country.

Objectives

- Ensure timely disbursement of Scholarships to the students
- Provide a common portal for various Scholarships schemes of Central and State Governments
- Create a transparent database of scholars
- Avoid duplication in processing
- Harmonization of different Scholarships schemes and norms

Comprehensive Dashboard/MIS System and monitoring system

- Facilitate monitoring at every stage of Scholarships distribution i.e. from student registration to delivery of funds
- NSP advance MIS system allows all stakeholders to generate their on-demand customized report.

Benefits

- Simplified process for the students
 - All scholarships information available under one umbrella
 - Single integrated application for all scholarships
- Improved transparency
 - System suggests the schemes for which a student is eligible
 - Duplicate can be reduced to the maximum extent

Intelligent rule Engine



- NSP is enriched with an intelligent rule-engine based Scheme Identification, that automatically populates schemes for which a student is eligible.

Achievements

In the Academic Year (AY)2018-19, 10 Central Ministries/Departments and 9 States have on-boarded their 60 scholarship schemes. Approximately 1.55 crore applications have been received and over 68 lakh students have received scholarships amount upto Rs.2,342 crore. Disbursement under a few Central and State schemes is in process.

Impact: National Scholarship Portal is increasingly being adopted by various Ministries

and educational institutes for offering scholarship schemes to eligible students. The portal is emerging as a primary channel to apply for scholarships among students. All major central sector schemes and centrally sponsored schemes are already on-boarded on NSP, while many States have also shown their keen interest to process their State-owned scholarship scheme through NSP, so that they could also harness the benefit of the national level platform.

On the other hand, the ultimate beneficiary, i.e., the students are also finding it very easy to identify and apply for the most suitable scheme for themselves. The scholarship amount is directly transferred/disbursed to in their bank account in a timely manner.

2.2.2.4 Digital Locker & other Initiatives

Digital Locker

Digital Locker is a key initiative under Digital India, the Indian Government flagship programme aimed at transforming India into a digitally empowered society and knowledge economy. Targeted at the idea of paperless governance, Digital Locker is a platform for issuance and verification of documents and certificates in a digital way, thus eliminating the use of physical documents. Indian residents who sign up for a DigiLocker account get a dedicated cloud storage space.

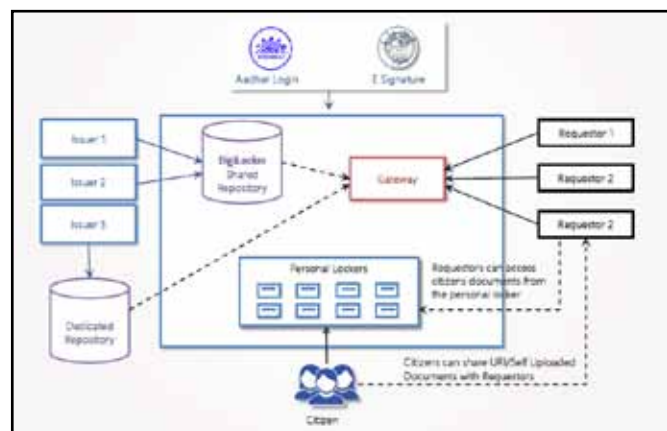

Ecosystem of DigiLocker

Organisations that are registered with Digital Locker can push electronic copies of documents and certificates (e.g. Driving License, School certificates) directly into citizens' lockers. Citizens can also upload scanned copies of their legacy documents in their accounts. These legacy documents can be electronically signed using the eSign facility.

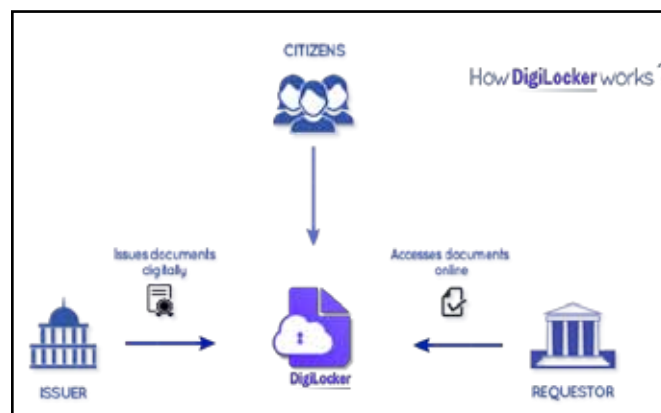

Working of DigiLocker

The following are the key stakeholders in the Digital Locker system:

- **Issuer:** Entity issuing e-documents to individuals in a standard format and making them electronically available, e.g. UIDAI, CBSE, Ministry of Road Transport and Highways, etc.
- **Requester:** Entity requesting secure access to a particular e-document stored within a repository, e.g., University, Passport Office, Regional Transport Office, etc.
- **Resident:** An individual who uses the Digital Locker service based on Aadhaar number.

Benefits of DigiLocker

- **Access:** Citizens can access their digital documents any time, anywhere and share it online.
- **Paperless:** It reduces the administrative overhead of Government departments by minimizing the use of paper.

- **Authenticity:** Digital Locker makes it easier to validate the authenticity of documents as they are issued directly by the registered issuer.

Achievements for DigiLocker (Till 31st Dec. 2019)

- DigiLocker now provides access to over 373 crore authentic certificates from over 195 organisations
- 3.38 crores Registered Users
- CBSE, CISCE, 21 State Education Boards, Skill Development Agencies and Technical Education Councils are providing digital certificates through DigiLocker.
- e-District services of 20 States, Land Records from 4 States and PDS services of 6 States are integrated with DigiLocker.
- Ministry of Road Transport and Highways has been providing Driving Licenses and Vehicle Registrations through DigiLocker since last two years. As an important step to complement this initiative, Ministry of Road Transport and Highways issued an advisory to the State Transport departments to clarify that the Digital Driving Licenses, Vehicle Registrations and other documents such as insurance certificates provided through DigiLocker are at par with the physical documents.
- The photo identification documents such as Driving License and Aadhaar presented through DigiLocker will also be accepted as a valid proof of identity while travelling on Indian Railways. Ministry of Railways issued a notification in June 2018 in this regard.
- Ministry of Civil Aviation has issued a circular stating that if the passenger shows the Aadhaar/Driving License from the 'Issued Documents' section by logging into his/her DigiLocker account, the same shall be considered as valid photo identity documents at airports.

- UIDAI, LPG Vouchers, New India Assurance Co. Ltd., CBDT, PMGDISHA, and Ministry of Skill Development And Entrepreneurship among various others are integrated with DigiLocker.

2.2.2.5 Enabling All Schools with Virtual Classrooms

The objective of the project "Smart Virtual Classroom (SVC)" was to set-up smart virtual classroom facilities in 3,204 Govt. owned / controlled schools plus 50 District Institute for Education & Training (DIETs) in seven pilot States - Himachal Pradesh, Gujarat, Rajasthan, Tripura, Haryana, Andhra Pradesh and Tamil Nadu, with the focus to improve the quality of education to students in remote/rural parts of the country. A Centralized control system was established in Delhi at ERNET's data centre which hosted the MCU, Streaming/ Recording server and other associated component for multiparty audio/video interaction and also offline access of classroom sessions round the clock for learning/ collaboration between all the stakeholders.

The basic aim of the SVC project was to create technology enhanced classrooms that will foster opportunities for teaching and learning by integrating learning technology, such as computers, electronic white boards, projectors, specialized software, interactive audio-video systems, etc. Under the project, the operational usage training of SVC infrastructure was provided to the School and DIETs teachers where DIET act as a mentor. Specialized faculties take the live lectures in which other schools in that district as well as in the adjoining areas participate.

SVC is a scheduled, online, teacher-led pedagogical intervention where, unlike conventional classrooms, teachers are not present with learners physically but instead interact through public network in an online learning environment.

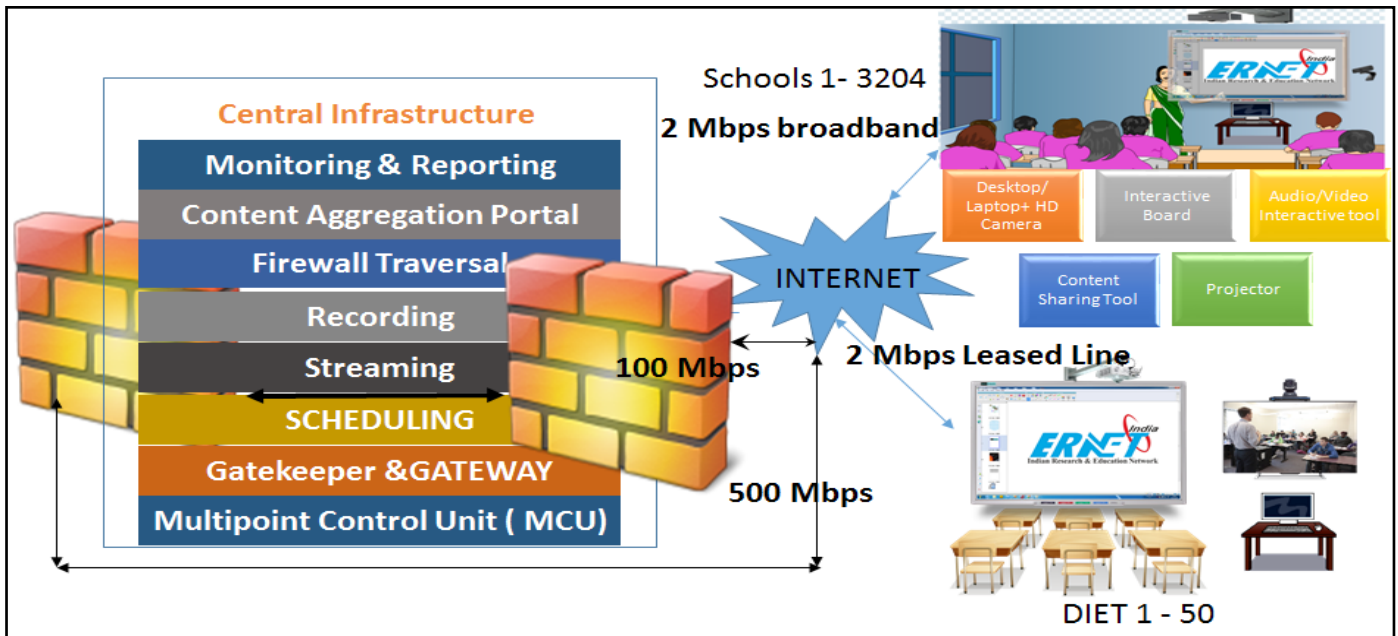

Enabling Schools with Smart Virtual Class Room Facility

Smart Virtual Classroom project’s specific deliverables and achievements:

- Established **1 Central Location** for Hosting MCU, scheduling s/w, Recording/ Streaming Solution for enabling storage of live sessions, offline access and multiparty conferencing.
- Established **50 high-end smart virtual classrooms** in each of the identified 50 DIETs, equipped with hardware based Video Conferencing & electronic teaching aid equipments.
- Established **3,204 smart virtual classrooms** in 7 States, equipped with Software based Video Conferencing & electronic teaching aid equipments. (Andhra Pradesh, Tamil Nadu, Gujarat, Rajasthan, Haryana, Himachal Pradesh, Tripura).
- Established **Knowledge aggregation portal** acting as a single platform for scheduling of sessions, data analytics, accessing off-line repository of sessions through a unique user name password.

- Imparted **operational hands-on training** to the DIETs/ school staff with a training manual.

Project usage statistics

- The live virtual classroom sessions are being conducted through multiple DIETs and total 4,702 such sessions conducted during 2019-20.
- 65,092 teachers have been trained till date under the project for operational skill set.
- 70,77,600 students attended the live sessions till date and increasing on daily basis.
- 16,263 sessions conducted through Smart Virtual Classroom since the inception of this concept.

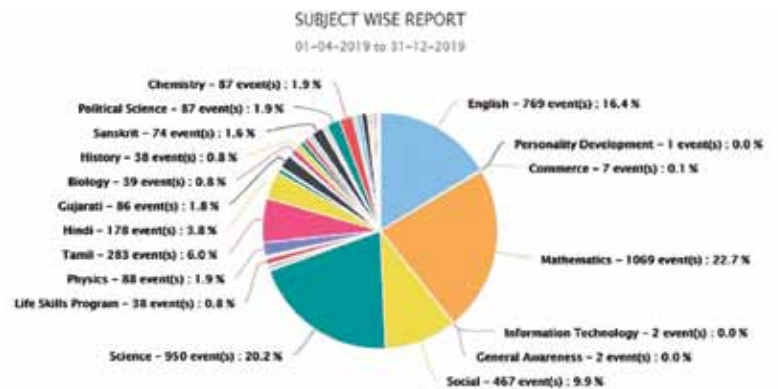



Social Initiatives Undertaken by ERNET through Smart Virtual Classroom (SVC)

• **Social and Vocational Focus: -**

Various sessions/lectures have been conducted regularly towards social awareness and Vocational focus. Social focus includes Environmental Education, Human Right Education, Yoga Education, E-waste Management, Dengue Awareness, Disaster Management, Personal Hygiene, Swachhta Awareness, Promotion of Digital Payment, etc. Vocational focus includes IIT/ JEE medical preparation, NEET Preparation, Career Counselling, B.Ed. training, etc.

• **Launching of Fit India Movement: -**

“Fit India Movement” was launched by Hon’ble Prime Minister Shri Narendra Modi on the occasion of National Sports Day through Smart Virtual Classroom infrastructure on 29th Aug, 2019 from 10:00 AM to 11:15 AM.



The stream was seen by more than 40 Schools across Haryana using the Smart Virtual Classroom infrastructure. Hon’ble Prime Minister focussed that Fit India Movement is the need of the hour and intends to lead India towards a Healthy future. The Hon’ble Prime Minister also asked people to take part in the Movement to make India healthy. Few of the Photographs of the session being streamed through SVC and watched by Students in schools is below:

Presenter	Date	Participant Schools	Students benefited
Parallel stream from DIET Gurugram	29.08.2019	40	800

Celebration of 150th birth anniversary year of Mahatma Gandhi

Special Lecture on Voluntary Community Services:

On the occasion of 150th birth anniversary year of Mahatma Gandhi, ERNET India under the guidance of Ministry of Electronics and IT, Govt. Of India conducted a session on “Voluntary Community Services” using Smart Virtual Class Room for class 10th to 12th students and DIET staffs on 29th Aug, 2019 from 12:35 pm to 01:30 pm.

Few of the Photographs of the session being streamed through SVC and watched by Students in schools is below:

Presenter	Date	Participant Schools	Students benefited
DIET Gurugram	29.08.2019	200	4000



Competitive Exam Specific Feedback

DIET Kota Conducted regular preparatory sessions for IIT/JEE and medical competitive examinations

during 2018-19. According to the JEE mains result declared in April 2019 Twenty-Two Students qualified JEE Mains Exams after benefitting from regular Smart Virtual Classroom sessions from Kota, Rajasthan. Many of the schools also mentioned that their overall school result improved due to such sessions.

Smart Virtual Classroom Transition and handover to State Education

The project was fully funded under Grant-in-Aid by MeitY for Implementation along with 2 years of funding support for O&M. The O & M handover has been completed on 31st December 2019 for all States.

2.2.2.6 Open Government Data (OGD) Platform for National Data Sharing and Accessibility Policy (NDSAP)

The Open Government Data (OGD) Platform India (<https://data.gov.in>) has been set-up by the National Informatics Centre (NIC), in compliance with the National Data Sharing and Accessibility Policy (NDSAP). The objective is to provide proactive access to Government owned shareable data along with its usage information in open/machine readable format, through a wide area of network across the country, in a periodically



Open Government data Platform for Portal

updated manner, within the framework of various related policies, rules, and acts of the Government. Developed using Open Source Stack, the project is one of the initiatives under Pillar 6 (Information for All) of the Digital India initiative.

Similarly, Government Open Data License – India has been developed to give legal frame work to the data consumers wishing to use and build on top of public data. License also gives assurance of what they legally can and can't do with the data both commercially and non-commercially.

All users are provided a worldwide, royalty-free, non-exclusive license to use, adapt, publish (either in original, or in adapted and/or derivative forms), translate, display, add value, and create derivative works (including products and services), for all lawful commercial and non-commercial purposes.

As on 31st December 2019, there were 3,60,095 dataset resources, 8,000 catalogs published by 161 Ministry/Departments 1,892 Visualizations created, 20,709 Application Programming Interfaces (APIs) created, 346 Chief Data Officers on OGD India

Platform. It was viewed 299 lakh times and 76.70 lakh datasets were downloaded.

OGD is promoted through newsletters, social media, workshops, challenges and participation in data meets.

OGD also acts as a knowledge-sharing platform through online communities. It facilitates community participation for development of Apps, Information graphics, etc. by using the available datasets. Dedicated Community (<http://community.data.gov.in>) and event portals (<https://event.data.gov.in>) have also been developed to help in community engagement and event management.

OGD team regularly conducts events like Data Hackathon, Challenges, and Workshops etc. for promotion, data utilization and public engagement. OGD Platform, in association with Internet and Mobile Association of India (IAMAI) has organized Hackathon - “#OpenGovDataHack” for Students, Entrepreneurs, Innovators, Start-ups, Developers and Community to create unique and innovative service delivery Applications and Information-Graphics to foster innovation. The sectors selected

Open Government Data (OGD) Platform Dashboard

Achievements

Items	1 st April, 2017	31 st Oct, 2018	31 st March, 2019	10 th Oct, 2019	31 ST Dec, 2019
Dataset resources	75,146	2,31,792	2,66,640	323,782	3,60095
Catalogs	4,114	4,429	4,633	7,731	8,000
Contributed by Departments	105	141	144	157	161
Visualizations created	1,056	1,509	1,620	1,851	1,892
Application Programming Interfaces(APIs) created	444	7,861	10,808	16,494	20,709
Chief Data Officers	111	204	215	340	346
Viewed	103.8 lakh	193.4 lakh	212.2 lakh	241.9 lakh	249.0 lakh
Downloaded	42.2 lakh	62.0 lakh	66.3 lakh	74.7 lakh	76.7 lakh

for the Hackathon were Water and Sanitation, Transport, Education, Crime and Health.

#OpenGovDataHack was held in 7 cities across the country as well as online. The Esteemed Jury under the Chairmanship of Secretary, MeitY, evaluated the shortlisted Apps and selected One Winner, One 1st runner-up, Two 2nd runner-ups and eight consolation awards, which were given to the teams in the National Award Ceremony on 1st November, 2018.

Other Achievements:

- Launch of Online Hackathon on Data-driven Innovation for Citizen Grievance Redressal by MoS Dr. Jitendra Singh
- Launch of Online Challenge in #OpenGovDataHack2019 by opening Cities and Online Challenges for Students, Professionals, Startups, etc.
- Support for TN, Smart Cities, Punjab, Kerala SaaS Instances
- Presentation on OGD in 2nd Meeting of Committee on Database, chaired by Chief Economic Adviser

2.2.2.7 Electronic Transaction Aggregation and Analysis layer (eTaal-2.0)

National Informatics Centre (NIC), under the Ministry of Electronics and Information Technology (MeitY) has developed eTaal (Electronic Transaction Aggregation and Analysis Layer), an electronic dashboard, with the objective of providing overall view of e-Services, being delivered across the country under various e- Governance applications implemented.

eTaal has been in nation-wide operation since September, 2013 and approx. 3751 eServices from 21 Central Ministries and all 36 States and UTs have been linked to the dashboard with over 14,706 crore e-transactions recorded till 30th November, 2019. This reflects the Government-wide acceptability of the initiative in terms of its utility and importance. A series of workshops have

been organized in various states to discuss various features of eTaal and identify the new features that can be incorporated in eTaal 3.0 to make it more useful. It is felt that several new features may be considered for inclusion in eTaal 2.0 leading to eTaal 3.0.

MeitY and NIC have developed Electronic Transaction Aggregation & Analysis Layer (eTaal); URL: <https://etaal.gov.in>, as an electronic dashboard for providing a real-time aggregated view of eServices being delivered across different states and levels of government. eTaal provides an aggregated view of e-Transactions performed through eGovernance applications implemented including, but not limited to, the national-level projects like the 31 Mission Mode Projects (MMPs) defined under the National eGovernance Plan (NeGP). eTaal automatically pulls the e-transaction count from the applications integrated with it using Web Services technology.

The dashboard also facilitates the quick analysis of transaction data of various applications in tabular as well as graphical form enabling users to drill down to the lowest level of detail without impinging on the privacy of the service-seeker or the security and integrity of the application software.

S. No	Year	e Service Count	e Transaction Count (in crore)
1	2013-14	2042	318.80
2	2014-15	423	458.13
3	2015-16	422	812.99
4	2016-17	285	1235.61
5	2017-18	344	3600.74
6	2018-19	139	4247.65
7	2019-20	96	4062.94
	Total	3745	14736.85*

Note:*eTransaction count recorded till 30th November

Tasks Undertaken Under eTaal 2.0 Project

A number of tasks were undertaken under eTaal

2.0 project. A brief outline of the tasks undertaken is outlined below:

S.No	Description of Tasks Undertaken
1	Around 800 more eServices integrated. E.g. eDistrict (Assam), eDistrict(Telangana), eDistrict (West Bengal), TelanganaeSeva, Social Welfare Scheme, Digital Payments, CCTNS (Tamil Nadu) and Punjab Seva Portal etc.
2	Conducted eTaal 2.0 workshops in various states including Andhra Pradesh, Telangana, and Goa.
3	Developed eTaal mobile app for iOS. Will be available in App Store shortly.
4	Exclusive Ministry portal developed for MSME.
5	eTaal 2.0 developed with attractive BI visuals and heat map of India indicating eTransaction per 1000 population for different regions

2.2.2.8 e-Hospital Project/Online Registration System (ORS)

As part of the Digital India initiative of Ministry of Electronics & Information Technology (MeitY), NIC has developed the e-Hospital, e-BloodBank and ORS applications. The ORS portal was inaugurated by the Hon'ble Prime Minister of India on 1st July 2015. ORS is the patient interface of e-Hospital for citizens to book online appointment for the hospitals. ORS is accessible over the Internet. ORS is a system to link hospitals across the country for online appointment and providing patient centric services like viewing lab reports, checking blood availability status etc.

The e-Hospital application is the Hospital Management Information System for internal workflows and processes of hospitals. ORS as well as e-Hospital applications are hosted at NIC's National Cloud MeghRaj. The availability on cloud has relieved hospitals from application and server management. The e-Hospital application is

made available to Government hospitals on cloud through Software as a Service (SaaS) model. The e-Hospital system is a one-stop solution which helps in connecting patients, hospitals and doctors on a single digital platform. The e-Hospital application is developed based on the global healthcare standards like HL7, SNOMED-CT, ICD10 and LOINC, and Meta Data and Data Standards published by the Ministry of Health & Family Welfare (MoHFW).

Brief objective of the e-Hospital project: The objective of the e-Hospital project is to provide and extend application software related technical support and implementation of the cloud based e-Hospital, ORS and e-BloodBank applications. Apart from this, the project objectives involve provisioning of single interface for patients across the country for delivery of patient centric services and providing technical support to the hospitals through a dedicated helpdesk/call centre.

Current status of implementation: The modules which are currently available on cloud are Patient Registration (OPD & Casualty), IPD (Admission, Discharge & Transfer), Billing, Lab Information System, Radiology Information System, Clinic, Dietary, Laundry, Store & Pharmacy, OT Management along with ORS and e-BloodBank.

STATUS (Till 31st Dec. 2019)

- 345 hospitals have been on-boarded on e-Hospital, from which 268 hospitals are reporting
- 14.23 crore transactions have been generated through e-Hospital since Sept 2015 and over 2.5 lakh transactions on daily basis.
- 48 hospitals in Uttar Pradesh, 73 hospitals in Karnataka and 68 hospitals in Madhya Pradesh are using e-Hospital application
- ORS has been adopted by 237 hospitals across the country
- 32.69 lakh appointments have been booked from ORS since July 2015
- ORS is now available as a part of UMANG app.

Achievements made under the e-Hospital project:

- The e-Hospital application has been implemented in major hospitals like AIIMS (Delhi, Bhopal, Bhubaneswar, Rishikesh and Raipur), RIMS Imphal, KGMU Lucknow, Dr. RML Hospital Delhi etc.
- The states of Uttar Pradesh, Karnataka, Uttarakhand, Jharkhand, Manipur, Assam, Tripura and Madhya Pradesh have planned to roll out the e-Hospital application state-wide.
- Over 2.5 lakh transactions are being done from the e-Hospital application and approx. 3,000 appointments are being booked from ORS portal on daily basis.

2.2.2.9 Rapid Assessment System (RAS)

National e-Governance Division (NeGD) under MeitY has developed a Rapid Assessment System (RAS) for continuous feedback on e-services delivered by Government of India and State Governments. This system has multiple channels for receiving feedback and it is backed by analytics. Analytics will help RAS Integrated Departments/Ministries in continuous system improvement and better governance. It offers trigger-based service integration with department's process workflow through APIs.

A citizen may provide feedback using RAS through various channels – Web Portal, Mobile App and SMS. RAS Portal allows department to quickly build feedback forms as per their requirement, publish them and make these available to end users on Department defined triggers i.e. delivery of service etc. Departments have their own dashboard and have option to view reports. RAS offers Localized Feedback Forms, in 9 languages, i.e. Hindi, Gujarati, Bengali, Kannada, Malayalam, Marathi, Punjabi, Tamil and Telegu.

Physical Progress: As on 27th December, 2019, the RAS application has been integrated with 1,980 e-services of 360 departments in 28 States/UTs and 9 Central Projects/MMPs. Total 11.62 crore feedback requests have been sent till 27th Dec, 2019 and in response 24.51 lakh responses has been received (within a ratio of 2.10% of total feedback requests). Major integrated e-Gov applications of States, include Caste certificate, Income certificate, Domicile certificate, Birth & Death certificates and Central Projects namely VAHAN, SAARTHI, DigiLocker, DAY-NULM, UMANG & Central Pension Accounting Office.

2.2.2.10 Jeevan Pramaan

Jeevan Pramaan is a biometric enabled digital service for pensioners. The Pensioners of the Central Government, the State Governments or any other Government organisation can avail the benefit of this facility. One of the major requisites for the pensioners, post their retirement from service, is to provide life certificates to authorised pension disbursing agencies, such as, banks and post offices etc. following which, their pension is credited to their respective bank accounts. Digital Life Certificate (DLC) for Pensioners aims to streamline the process of getting this certificate and making it hassle free and much easier for the pensioners.

Transformative Impact

Jeevan Pramaan has provided relief to old aged persons by eliminating the need of physical visit to Pension Disbursing Agencies. It provides an opportunity for anytime, anywhere submission of Digital Life Certificate (DLC) by the pensioners. This has streamlined the pensioners' verification process at Pension Disbursing Agency. Cloud and Mobile enablement has enhanced the scalability and accessibility, and digitisation has cut down unnecessary logistic hurdles.

Month/Year	Total DLC's Registered (Lakhs)	Cumulative (Lakhs)
2014-15	6.01	6.01
2015-16	11.21	17.22
2016-17	76.26	93.48
2017-18	80.3	173.78
2018-19	88.76	262.57

Implementation status

- 88.76 lakh pensioners have registered on Jeevan Pramaan Portal since November, 2018.
- 65 PSAs (Pension Sanctioning Authority) including 23 States Governments are on-board on Jeevan Pramaan
- All major banks, EPFOs, DPDOs, Postal departments, Telecom etc. have been on boarded as PDAs (Pension Disbursing Agency). Several state treasuries, as applicable from state to state, are also on-boarded as PDA.

2.2.2.11 Aadhaar Enabled Biometric Attendance System (AEBAS)

Digital India's AEBAS Project has been established and rolled out during September 2014 in Government of India and extended to all State Governments successfully from March 2015.

It is an enabling system to register an employee's attendance by presenting his/her biometric (Finger Print/Iris), which is authenticated online within seconds in real time with UIDAI records. The Cloud-based software is installed and operated from NIC National Data Centre. Front end system is the BAS tablets or the desktop devices. The connectivity of terminals/devices is established through Wi-Fi/GPRS/LAN with Internet, Broadband or SIM based GSM connectivity on tablets.

8,452 Central and State Government Organizations are on-boarded with 32 lakh employees/Candidates registered. Real time attendance statistics are reflected in individual attendance dashboards. 1.20 lakh devices are installed across the country in form of Tablets/Desktop devices/Iris Scan machines. Close to 32 lakh employees/candidates are now marking attendance all over India on this system. Facility of advanced MIS reports is available with separate web-service feature.

AEBAS is made highly scalable and caters to various type of requirements with respect to Ministry scheme beneficiary verification and attendance, e.g. Skill Development trainees, Culture Ministry "Gurus", Sports Authority coaches and athletes, and so on.

AEBAS awareness workshops were conducted for representatives of Centre and States for Nodal Officers, Users and support engineers of Organisations across the country, face to face and through VC. Separate 24x7 Helpdesk team is rendering support to users. Various monitoring mechanisms have been enabled and are monitored online with SMS facilities on the health system of all AEBAS Servers and functions.

Timely updates and enhancements with necessary security features in accordance with UIDAI's security guidelines are being incorporated into the system for safety and smooth process.

2.2.2.12 Proactive Governance and Time Implementation (PRAGATI)

Hon'ble Prime Minister of India launched this ambitious multi-purpose and multi-modal platform PRAGATI on 25th March, 2015, as a part of Digital India program, e-Governance, reforming Government through Technology.

The Prime Minister of India started directly monitoring the progress of PRAGATI schemes /



PRAGATI Meeting Session in progress

projects using videoconferencing facility on every fourth Wednesday of the month. This is a Three Tier System: PMO, all Secretaries of GOI and chief Secretary of all States. This project brings all the Secretaries to Government of India and the Chief Secretaries of the States on a single platform, through which Prime Minister is able to discuss the issues with the concerned on Central and State officials directly with full information and latest visuals of the ground level situation. This make faster implementation of Central level schemes/projects, State level projects and resolution of grievances between State and Central level departments.

This is the PM's unique initiative of resolving bottlenecks in project implementation, cutting delays, reviewing the progress of flagship Government initiatives and keeping tabs on handling and resolution of public grievances. PRAGATI is turning out to be quite a help for the Government as it tries to speed up development schemes.

Every project or issue taken up at PRAGATI meetings comes with a deadline, which Government agencies have to adhere to. NIC managed around 150 sites participants in interactive mode during each PRAGATI VC session.

PRAGATI Project rolled out on March 25, 2015 has pushed 257 projects (Central/State) involving investment of around Rs. 12.05 lakh crore till date. 47 Programmes/Schemes of various Ministries/ Department and 17 Sector Grievances have been reviewed (Ministries/Department). Total of 31 PRAGATI sessions have been chaired by Hon'ble Prime Minister till January, 2020.

2.2.2.13 Digitize India Platform (DIP)

Digitize India Platform (DIP) is an initiative of the Government of India under the Digital India Programme to provide digitization services for scanned document images or physical documents for any Organization. The aim is to digitize and make

usable all the existing content in different formats and media, languages, digitizes and create data extracts for document management, IT applications and records management. This platform was launched in August, 2015 under Digital India.

Achievements

The main objective of this project to provide an end-to-end workflow-based IT framework for digitization of Government records to enhance service delivery to the citizen and to empower numerous self-identified volunteers, part-time workers, housewives, students and general public, who add small portions of their contribution through crowd sourcing mechanism to achieve the greater result.

DIP provides an innovative solution by combining machine intelligence and a cost-effective crowd sourcing model. It features a secure and automated platform for processing and extracting relevant data from document images in a format that is usable for meta-data tagging, IT application processing and analysis. Project has been closed on 31st March 2019.

2.2.3 Financial Transactions Electronic and Cashless

Electronic payments and fund transfers have the advantage of targeted and direct delivery to the intended beneficiaries without the involvement of middlemen who may otherwise subvert the system.

Similarly, online mechanisms for payment of fees for certain public services offer a transparent, friendly and expeditious channel to citizens for payments. It is envisaged that all financial transactions, above a certain threshold shall be made electronic and cashless. Further, there is also a move towards strengthening the implementation of Direct Benefits Transfer (DBT) by leveraging the “JAM Trinity” (Jan Dhan, Aadhaar and Mobile).

As Aadhaar is unique and does not change over the lifecycle of an individual, the 12- digit Aadhaar is

sufficient to transfer any payments to an individual. Today, in order to transfer money to a beneficiary, the Governments/ Institutions need to know the bank account, IFSC Code, and bank branch details etc. which is prone to change. However, Aadhaar offers the possibility of sending money by just using the 12-digit number for life without bothering about any changes in the bank account of the individuals. Thus, with this unique property of being valid for a lifetime, Aadhaar is very well perceived as a Financial Address in the banking sector.

2.2.3.1 Direct Benefit Transfer (DBT)

Fee Reimbursement to Scheduled Caste and Scheduled Tribe with financial support of MeitY under which free training is provided to SC/ST candidates at NIELIT Own Centres

- **Fee Reimbursement to Scheduled Caste and Scheduled Tribe**

As per the directions received from Planning Commission through MeitY (then DeitY) Vide their communication No.D.O.No.M-13054/2/2005-BC dated 05.09.07, NIELIT is implementing a programme titled “**Fee Reimbursement to Scheduled Caste and Scheduled Tribe**” under the Scheduled Caste Sub Plan (SCSP) for Scheduled Castes and Tribal Sub-Plan (TSP) for Scheduled Tribes. According to the directions and guidelines for implementing the scheme, no fee should be charged from the SC and ST candidates for educational and skill development programmes by the Government and autonomous institutions and the expenditure for the Scheme should be accounted for from the SCSP and TSP fund of the respective Ministries /Departments.

Since 2007-08, NIELIT Centres are implementing the programme with financial support of MeitY. Under this programme, NIELIT Centres do not charge fees from the SC or ST candidates for undergoing courses offered by NIELIT. Further, there is no exclusive batch/schedule of training

under this scheme and the beneficiaries are trained as per general training schedule of the respective NIELIT Centre.

Current Status:

Recently, the programme has been notified under Section 7 of the Aadhaar Act 2016 vide Gazette Notification No. D. L.-33004/99 dated 10th August 2019. The courses offered under the programme are limited to NSQF aligned Non-Formal Courses / Formal Courses in association with universities and are conducted at NIELIT's own Centres. The Course Fee is reimbursed in accordance with the Gazette Notification as per the Schedule-I of Common Norms issued by Ministry of Skill Development and Entrepreneurship (MSDE) vide even notification no. H-22011/2/2014-SDE-I dated 15.07.2015, dated 20.05.2016, dated 28.02.2017 & dated 31.12.2018 or the actual charges of NIELIT whichever is less.

Status of MIS Development for the programme:

The development of MIS portal is almost on the verge of completion. NIELIT used the e-pramaan service of C-DAC for aadhaar based authentication of student which is essentially required in DBT portal. Further, testing for Aadhaar authentication module has been done on development system and is under process on pre-production server. Thereafter, the security audit of application is to be carried out followed by integration with DBT Portal.

2.2.4 Technical and Other Support

2.2.4.1 e-Gov App Store

The e-Gov AppStore (<https://apps.gov.in>), launched in May 2013, is a National level common repository of customizable and configurable applications, components and web services, that can be re-used by various Government agencies/departments at Centre and States, with the vision to accelerate delivery of e-services as envisaged under NeGP and optimizing the ICT spending of the Government. Core and Common applications that have high demand and are replicable across the Central and State levels, are the potential applications to be included in e-Gov AppStore and they can be hosted on the National Cloud. The project enables re-use of already developed applications without incurring further cost and effort in development of those applications. Therefore, the Appstore facilitates the Government Departments with the following objectives:

- Speeding up the development and deployment of e-gov applications.
- Easy replication of successful applications across States.
- Avoid duplication of effort and cost in development of similar applications.
- Ensure availability of certified applications following common standards at one place.

The number of candidates trained in 2018-19 and fee reimbursement claimed from MeitY is as under:

Duration	No. of SC Candidates trained	Fund claimed according to Common Norms (Rs.)	No. of ST Candidates trained	Fund claimed according to Common Norms (Rs.)	Total Trained	Total Fund received in (Rs.)
2018-19	6,237	7,37,17,326/-	23,182	15,07,47,521/-	29,419	22,44,64,847/-

Achievements

- Currently, 61 applications (51 Apps, 8 components and 2 web services) are uploaded on eGov App Store and 19 applications have been funded for productization under the outlay of the project
- Selection Criteria prepared for short listing applications for productization/re-engineering has been finalized.
- Important guidelines on Application Development & Re-engineering have been prepared in consultation with various Govt. & Private agencies (CGG, CDAC, NIC & industry experts) and published.
- State level awareness workshops have been organized in various states to educate the Application Owners on Cloud ready application development & deployment
- “Revamping of MMPs /Projects” i.e. Transport, PDS, Prisons, Scholarship etc. was undertaken.
- AppStore Portal has been upgraded to a new version with improved performance and upgraded framework, and increased functionality.
- On boarding guideline has been uploaded on eGov AppStore portal.

2.2.4.2 Development of Common Minimum Framework (CMF) for Government Websites :

- Websites of 92 Ministries/ Departments/ Apex bodies have been made accessible as per the following:
 - Websites of 66 Ministries/ Departments/ Apex bodies migrated to the Content Management Framework (CMF)
 - 26 Ministries/ Departments/ Apex bodies were guided and technically supported to make their websites accessible

- 7 more Ministries/ Departments/ Apex bodies have on-boarded to CMF to make their websites accessible
- Training provided to officials of 57 Ministries/ Departments for Content Management of websites
- Training provided to officials of 55 Ministries/ Departments for obtaining Website Quality Certification by STQC
- 17 Government offices/ entities were provided with the CMF Core Framework for developing accessible websites
- Review and testing for websites’ quality and performance was carried out
- Provided comprehensive WQR to stakeholders of the Ministries/ Departments/ Apex bodies in order to achieve consistent compliance to W3C’s Web Content Accessibility Guidelines (WCAG 2.0), The Rights of Persons with Disabilities Act 2016, Information Technology Act of India and Guidelines for Indian Government Websites (GIGW).

2.2.4.3 India Portal

India Portal, a Mission Mode Project in the integrated services category under the NeGP (National eGovernance Plan), that provides a ‘single-window access’ to information and services that are electronically delivered from all Government departments, institutions and organisations. It has been a most popular source of information to a wide range of stakeholders - from citizens, to Government, to business and to Indian diaspora. It is a gateway of Indian Government websites at Centre, State and District levels. India Portal is built from the citizens’ perspective and information and services are categorized and presented in a way the citizens want. The portal is also integrated with MyGov and Data Portal to present the citizen engagement activities and open data across various sectors.

The India Portal has over 2.5 million visitors per month (5.4 million page views) and 4.25 lakh registered users. India Portal is also a platform for the promotion of various Government initiatives/events such as:

- Micro site for Republic Day showcasing the Republic Day celebrations, President's speech to the nation and awardees of various awards that has been designed, developed and maintained at <http://knowindia.gov.in/republicday/rpday.php>
- Micro site for Independence Day which is maintained at <http://knowindia.gov.in/independenceday/independenceday.php>.
- Spotlights covering important Government initiatives and events like Pradhan Mantri Kisan Sampada Yojana, National Initiative for School Heads' and Teachers' Holistic Advancement (NISHTHA), SE Shagun - School Education Shagun, PradhanMantri Shram Yogi Maan-dhan (PM-SYM) - A pension scheme for unorganised workers, Union Council of Ministers 2019, Nai Manzil: An integrated Education and Livelihood Initiative for the Minority Communities, Voter Information, Rashtriya Vayoshri Yojana, Pradhan Mantri Annadata Aay SanraksHan Abhiyan (PM-AASHA), Bhasha Sangam - Celebrating the Linguistic Diversity of India
- Monthly newsletters that are sent to subscribers of India Portal to keep them updated about the latest happenings related to the nation.

The portal also has a Social Media presence through

- Facebook page that is maintained at <https://www.facebook.com/NationalPortalIndia>
- Twitter handle is maintained at <https://twitter.com/indiagovin>

Other initiatives/activities under the aegis of India Portal are:

Guidelines for Indian Government websites ([https:// web.guidelines.gov.in](https://web.guidelines.gov.in)):

GIGW were formulated under the India Portal project and aim at achieving the objective of making the Indian Government websites Usable, User-Centric and Universally Accessible. GIGW address the leading practices involved in the entire lifecycle of websites, web portals and web applications right from their conceptualization, design, development, maintenance to the management stage.

The first version of Guidelines for Indian Government Websites (GIGW) was released in 2009. Consequently, with the change in technology and user needs, a new version of the guidelines was proposed and has come into effect from February 2019. The new version features inclusion of the latest standards in web technologies and accessibility, and a new section with guidelines pertaining to Mobile Apps. Two certification schemes are also in place, one with respect to compliance with GIGW v2 and the other with respect to accessibility compliance. GIGW has also been adopted by DARPG and included in the Central Secretariat Manual of Office Procedure (CSMOP).

Digital India Awards (<https://digitalindiaawards.gov.in>)

Digital India Awards under the ambit of India Portal have been instituted to acknowledge the exemplary initiatives in digital governance. Government entities at the Centre, State, district and local levels and Indian missions abroad are eligible to participate in the awards. The awards are biennial and the 5th edition of Digital India Awards was organized in 2018. The previous four editions of the awards were held in the years 2009, 2012, 2014 and 2016.

Last edition of the awards saw the inclusion of a new category Emerging Technologies to recognize



brilliance in the use of new technologies such as Artificial Intelligence, Block Chain, Internet of Things, Machine Learning, Natural Language

Processing, Voice User Interface, Big Data & Analytics. It witnessed an enthusiastic participation from across the nation with around 600 nominations received from Government entities at Centre, State, district and local levels. The nominations were shortlisted using a scientific methodology and the awardees were chosen by a jury comprising of representatives from Government, academia and industry. In DIA 2018, 35 awards were conferred in 10 categories by the Hon'ble Minister of Electronics and Information Technology, Law and Justice, Shri Ravi Shankar Prasad, in a ceremony held on 22 February 2019 that was witnessed by participants from across the country. Compendium of winners was also released during the event.

National Government Services Portal (<https://services.india.gov.in>): To facilitate the availability of online services that are provided by various Government entities from one platform, in a citizen centric manner under categories like health and wellness, education and learning, money and taxes, National Government Services Portal has been developed. The portal lists 9860 services that can be searched by categories. The portal also features an advanced search where the services can be searched by location and PIN code. The portal has a distributed content contribution system



National Government Service Portal

where each Ministry/department and State can contribute and manage their own services. The portal also sources its content from other initiatives like ServicePlus and UMANG (Unified Mobile Application for New-age Governance).

Know India (<https://knowindia.gov.in>): This website showcases India's profile, its unique and rich culture & heritage, National Identity Symbols, States/UTs/Districts etc. The microsites on republic day and independence day celebrations are a part of this website.

2.2.4.4 Setting up of India Enterprise Architecture (IndEA)

Under the overarching vision of Digital India, Government of India aims to make all Government services digitally accessible in an integrated manner to citizens through multiple channels, such as web, mobile and common service delivery outlets. In order to facilitate better governance to citizens and enable whole-of-Government approach, policy integration and use of big data analytics is required. These trends require breaking of sectoral barriers and silos and re-architecting the Government as a single enterprise. Keeping in view the above facts, MeitY formulated India Enterprise Architecture (IndEA) Framework along with its Adoption Guide.

The vision of IndEA is “to establish best-in-class architectural governance, processes and practices with optimal utilization of ICT infrastructure and applications to offer ONE Government experience to the citizens and businesses”. IndEA provides a generic framework, comprising of a set of architecture reference models, which can be converted into a Whole-of-Government Architecture for India, Ministries, States, Govt. Agencies etc. The IndEA framework is based on Federated architecture approach and recognizes need to accommodate both green field (new) and brown field (existing / legacy) e-Gov initiatives.

IndEA shall provide an opportunity to the Government Departments to revise their service portfolios and undertake process reforms leading to transformation in e-Governance rather than automation. IndEA shall help the Government in achieving cost-effectiveness through use of shared infrastructure and services. IndEA shall enable cashless, paperless, frictionless, personalized, time bound and quick delivery of Government services to the citizens. After implementation of IndEA, citizen can experience a seamless ONE Government Experience.

For pilot implementation of IndEA, a project titled ‘To set-up India Enterprise Architecture (IndEA) Division at NeGD’ has been initiated in March, 2019 under which 2 Ministries/Departments and 2 States/UTs have been targeted. One State and one Ministries have been finalised i.e. Meghalaya and Ministry of Agriculture, the remaining Ministry and State for pilot study would be finalized shortly.

Achievements

The MeghEA vision document is currently under finalization stage. The vision document maps the departmental goals and services to the State goal of becoming a high income State by 2030, while mapping to UN Sustainable Development Goals (SDGs).

2.2.4.5 Capacity Building Scheme 2.0

The Digital India led transformation requires considerable enhancement of capacities within the Government at both the Central and the State levels to lead and manage various Digital Governance initiatives. In order to address the emerging and increasing need to build internal capacity in the Government to envision, conceptualise and implement digital transformation, Capacity Building (CB) scheme was launched in 2009. The scheme's phase-II started in January, 2015 and is upto March 31, 2020.

Capacity Building scheme components broadly cover:

- **State e-Mission Teams (SeMTs):** Professional and technical manpower support to the States/UTs;
- Various need-based training programmes and thematic workshops that range from short duration sensitization and awareness sessions to long duration in-depth, role-based trainings;
- **Learning and Knowledge Management System (LMS & KMS):** Technology enabled learning and knowledge management for anytime, anywhere learning and sharing;
- **Content development and strengthening of training institutes, collaborations and partnerships:** Covers content and faculty support to ATI & CTI and incorporates digital governance modules in the regular calendar, besides collaboration with premier institutes for conducting capacity building programmes.

With the recent focus on new emerging areas, enterprise architecture and cyber security, new programmes, such as Cyber Surakshit Bharat has been introduced and existing programme modules like CIO programme has been revamped and revised, accordingly. Various need-based training modules have been developed and standardised. Also, a resource pool has been identified and trained under Train the Trainer programme to scale up capacity building efforts across the country.

The details on capacity building components and programmes are also available at www.negd.gov.in.

Achievements (till Dec., 2019)

SeMT support to States/UTs: Recruitment for vacant positions in SeMTs was initiated in June 2018. 28 employees have joined since 1st April 2019. Current Strength is 171 in 36 States & UT out of approved strength of 231.

Training is an ongoing activity offered to various Central and State level officers, from time-to-time. In the FY 2019-20, 156 Government officers from various Central and States ministries/departments and other organisations are trained in relevant training programmes. The programmes conducted are as follows:

- **Chief Information Officer’s training programme** is a high value programme targeted at policy programme and project level Government officers from the Centre and the States, who are involved in leading and managing e-governance projects. The programme comprises of domestic and international exposure components and has two variants - Leadership and Champions level. Some of the recently conducted CIO programmes were based on new emerging areas (such as AI, Block Chain, Enterprise architecture, IOT, Cyber security, DSS, Design & thinking etc). Two programmes have been conducted in FY 19-20 including



Mr. Ajay Prakash Sawhney, Secretary, MeitY with the participants of eGovernance Leadership programme held in New Delhi.

Leadership and Champions, and international exposure visits covered were to New Zealand and Singapore.

- **Thematic Workshops:** These theme based workshops intended to create awareness on the new, critical focus areas. One workshop was organised based on the emerging technologies (such as Blockchain, IOT, AI, etc.) in collaboration with MCHRD, Telangana for Government employees.
- National e-Governance Division (NeGD) has partnered with Indian Institute of Management, Visakhapatnam (IIM-V) to launch a bespoke MBA programme specialising in digital governance and management. The programme is a judicious mix of management and technology courses offered in classrooms and in virtual mode (to minimise absence from work situations of participants). A capstone project of practical importance and international immersion of two weeks are also part of the programme. The program is going to commence from Jan 6, 2020.
- **Collaboration with Apex & Administrative Training Institutes:** The scheme especially focuses on strengthening training and academic institutes within and beyond the Government sector to maximise its reach for covering officials and simultaneously, seed in e-governance as a part of the curriculum in various Central and Administrative Training Institutes (ATIs-CTIs). All partner institutes have been conducting specialised trainings; CIO and CISO role-based trainings; thematic workshops; and developing master trainers in e-governance along with facilitation from NeGD. Content and faculty support has been provided to ATI-Mysore, NIFM-Faridabad, IGNSA-Dehradun, MGSIPA-Punjab and DIT-Delhi, Uttarakhand, Jammu and Kashmir, and Uttar Pradesh (UP). During this year,

MOUs were extended with existing partners and National Productivity Council has also collaborated with NeGD.

This innovative model has sensitised 438 Govt. officers in 11 cadre based training programmes, on various topics of e-Governance and Digital India ecosystem.

- **Learning Management System (LMS)** (<https://lms.gov.in/>): A virtual learning platform for administration, documentation, tracking and reporting of training programmes, classroom and online events, e-learning programmes, and training content.
 - o 45+ Trainings institutes have been onboarded so far. 4000+ registered users, 500+ Group A officers have been trained and 200+ Group A officers are as of now leveraging online trainings.
 - o In the last six months, 34 Webinars conducted with 17,988 Participants. On 05 April 2019, NeGD was honored by Revenue Secretary/Chairman GSTN with an award in recognition of the valuable contribution and support in development of Goods and Services Tax (GST) ecosystem.
 - o NeGD, under the Digital India programme has taken the initiative to offer 'Online PG Diploma in Cyber Law, Crime Investigation & Digital Forensics' in a phased manner to 1,000 officials including Police, State Cyber Cells, Law Enforcement Agencies, Prosecutors and Judicial Officers through Learning Management System (LMS). It is a separate project funded by CLeS Division, MeitY. This programme will be conducted in collaboration with consortium of NLIU (Bhopal) and other law schools/ universities, such as National Law University (Delhi),

National Law School of India University (Bengaluru), Rajiv Gandhi National University of Law (Patiala) etc., in the hub and spoke model, throughout the country. The program will commence from January 15, 2020.

- In order to support knowledge management in Governance, a **Knowledge Management System (KMS)** (<https://kms.gov.in/>) has been developed under Digital India programme. It facilitates access, collaboration and sharing of information and knowledge on e-governance issues and projects under Digital India. Department of Administrative Reforms and Public Grievances (DARPG), Bureau of Indian Standards (BIS), State Government of Meghalaya and Income Tax Department have requested the NeGD KMS services.

The status of training programmes and workshops conducted under CB scheme phase II in FY 2019-20 is stated below:

Training Programme/ Workshops	No. of Programmes	No. of Participants
Thematic Workshop (On emerging technologies)	1	65
Chief Information Officer (CIO) programme	2	44
Orientation program for SeMTs	2	47
Innovative engagement model with State Administrative / Central Training Institutes by seeding e-Governance training module in cadre based training programmes.	11	438
TOTAL	16	594

2.2.5 Common Services Centers (CSC-2.0: A Way Forward Project)

The Common Services Centers (CSCs) are internet enabled access points for delivery of various Digital Services (eServices) to the citizens. The CSCs enable citizens to avail the Government and other services closer to their locality in an effective & transparent manner. The primary objective of the CSC is to provide e-Governance services within the reach of the citizen, by creating the physical service delivery ICT infrastructure. It helps in making a transparent service delivery mechanism and eliminating citizens' effort in visiting Government offices.

CSCs are run by Village Level Entrepreneurs (VLEs), who are co-opted into the ecosystem from the community they serve. To ensure sustainability of the CSC, the entrepreneurship capabilities of the VLEs are nurtured from time to time through Entrepreneurship Development Programmes (EDP) and training workshops.

The CSCs aim to provide individual access to internet and access devices to citizens in rural India where the ICT intervention is very low, thereby, reducing / eliminating the digital divide. CSCs being well equipped ICT enabled centers necessarily play a significant role in enabling universal access to plethora of e-Services for citizens and acting as cornerstone for the citizens' digital empowerment, hence creating a transparent governance ecosystem. Altogether, these CSCs are becoming a game changer by providing a common Information Technology (IT) platform for rural citizens.

Today, CSCs are more than service delivery points in rural India. They are positioned as change agents, promoting rural entrepreneurship and building rural capacities and livelihoods. They are enablers of community participation and collective action for



engendering social change through a bottom-up approach with key focus on the rural citizens.

This Ministry has launched CSC-2.0 Project in August, 2015, under Pillar-3 of Digital India Programme, to expand the outreach of the CSCs to all 2.50 lakhs Gram Panchayats (GPs) across the country and to make the CSCs the integral part of the Digital India Programme. It has aimed to set up at least one CSC in every GP across the Country.

The CSC-2.0 is envisaged as service delivery & transaction based self-sustainable model, delivering a large bouquet of e-services through a single delivery technological platform known as Digital Seva Portal (DSP), which would increase the sustainability of the CSCs across the country. As on 30th November, 2019, there are total 3,65,490 CSCs are functional in PAN India, out of them, 2,68,931 CSCs are functional at Gram Panchayat (GP) level.

CSC – Service Delivery platform: Digital Seva Portal (DSP)

The number of services offered by CSCs has increased steadily over the years and the CSCs are offering more and more G2C services (Central and State Government services), UIDAI Services, Election Commission Services, Digital literacy and other educational, banking & FI services, Agriculture related services through IFFCO, healthcare services, Digital Payments, Insurance, Pension, Skill Development, and other B2C services (IRCTC, Utility Bill Payment, E-Commerce, E-Recharge) through Digital Seva Portal.

Currently, 28 central Government services are offered to the citizens through the CSC network using the centralized Digital Seva Portal. State G2C services, ranging from 10 to 400 in various States, are also being delivered through the CSCs in collaboration with various State governments and

their departments. By partnering with Government and private service providers, CSC -SPV is enabling the CSCs to deliver a wide range of services and thus ensuring the viability and sustainability of the CSCs. The total number of services being delivered through the CSCs, including B2C services, is around 350+.

New Initiatives through CSCs

During the Financial Year, 2019-20, CSC e-Governance Services India Limited (i.e. CSC -SPV), under the guidance of the Ministry of Electronics & Information Technology (MeitY), has undertaken a number of new initiatives and engaged the CSCs to implement various flagship programmes of the Government under Digital India Programme for digital empowerment and simplifying life of people through citizen centric service delivery efforts.

A few of the important new initiatives as well as other services that are implemented and provided through the CSCs are:

- Ayushman Bharat Yojana
- Pradhan Mantri Kisan Maandhan Yojana (PM-KMY)
- Pradhan Mantri Shram Yogi Mann-dhan Pension Yojana (PM-SYM)
- Pradhan Mantri Fasal Bima Yojana (PM-FBY)
- 7th National Economic Census
- National Pension Scheme (NPS)
- FASTag Registration & Distribution
- Jeevan Pramaan
- FSSAI Registration
- Udyam Parichay / Udyam Jyoti
- HIMCARE - Himachal Health Care Scheme

- Tele-Centre Entrepreneurship Course
- Printing of Ration Card in Himachal Pradesh
- Tele-Centre Entrepreneurship Course
- HDFC Current Bank Account Opening
- PWD Scheme
- E-Courts Service
- Sarathi Services
- LPG Booking
- E-Stamp
- Product Distribution

Other programmes of national importance:

Apart from the above noted initiatives, during the Financial Year, 2019-20, CSC e-Governance Services India Limited implemented the following Programmes/ Projects of national importance –

- Pradhan Mantri Digital Saksharata Abhiyan (PMGDISHA)
- Wi-Fi Choupal
- Setting up of Sanitary Napkin Micro Manufacturing Units
- Digital Village

Generation of employment through CSCs

CSCs have been promoting entrepreneurship in rural and semi-urban areas and creating employment avenues locally as majority of the CSCs employ around 3-4 persons from the community for running their activities. Besides, CSCs have also been setting up Micro Manufacturing Units for sanitary napkins, LED bulbs, paper plate making, etc., which additionally employ around 5-10 persons in a CSC. In a rough estimate, today, around 10 lakh people have been provided direct or indirect employment through their engagement with CSC across the country.

Services through CSCs under CSC ecosystem:

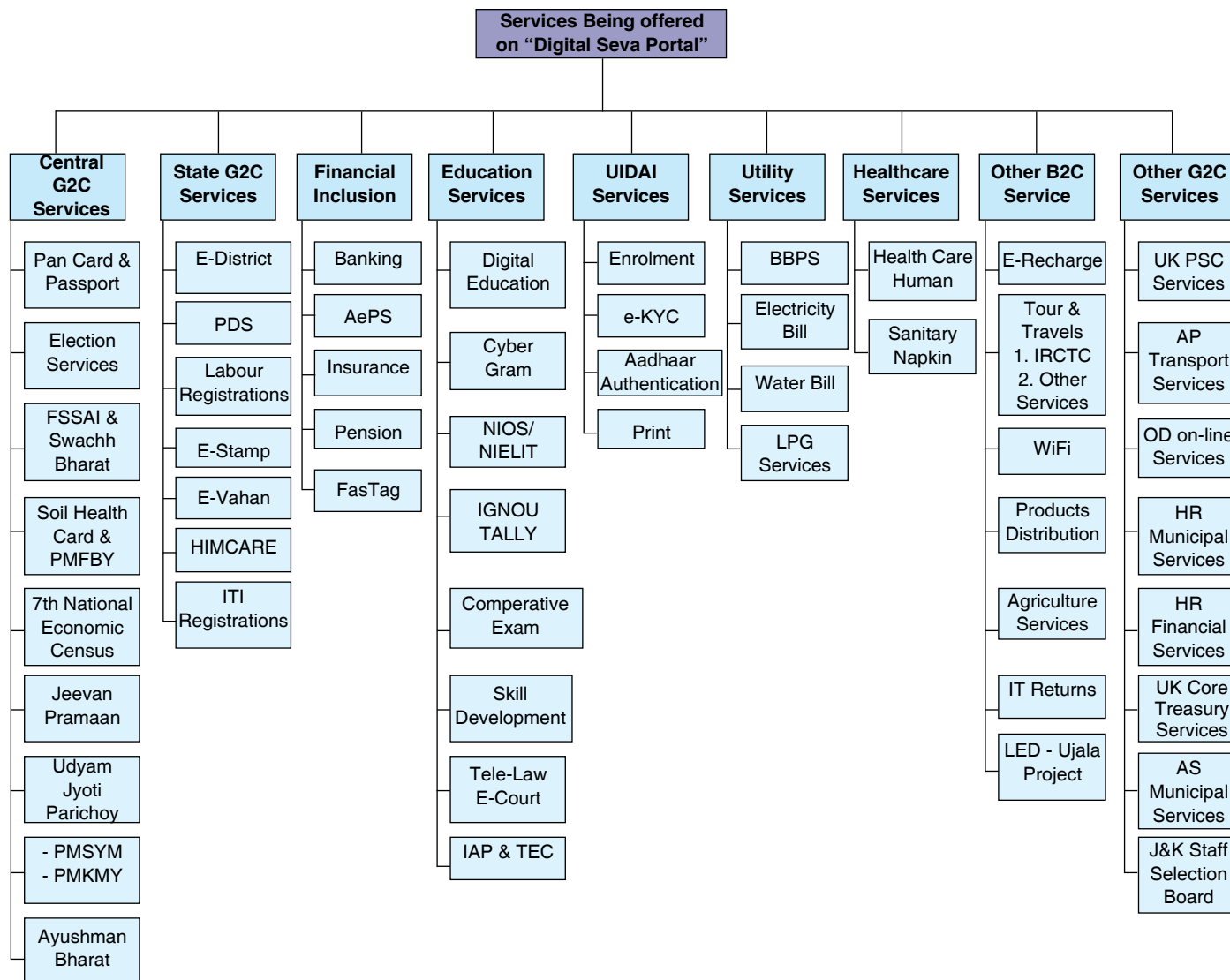

2.3 Digital India Initiatives by NIC

With its Digital India Programme, government has embraced technology driven solutions for providing effective governance that leads to all-encompassing growth and access to public services for all its citizens. ICT initiatives are making treads in bridging the digital divide within the country by creating an information society where citizens are aware and empowered. National Informatics Centre (NIC), an attached office of MeitY, provides nationwide ICT infrastructure to support e-Governance services

and various initiatives of Digital India. Since last four decades, NIC has been associated with design and development of software for improving delivery of services undertaken by government departments at Centre, State and District level. NIC platforms and services are being offered through multiple technology interfaces thereby providing rich benefits of enterprise mobility and accessibility on the go covering practically all core sectors of governance - health, education, agriculture, rural development, finance and many more. Through initiatives like MyGov, eVisitors, eCourts, e-Hospital, e-Transport,



Digitizing Core Sectors for Sustainable National Development

TPDS, eProcurement, ICT solutions have radically transformed government services delivery system. Last-mile delivery of government services has now become a reality.

Pradesh, CSCs, mFMS, CM/DM Dashboards and e-Disha. Infrastructure enhancement and e-learning sessions are conducted regularly for capacity building and effective service delivery.

2.3.1 Agriculture

2.3.1.1 Soil Health Card Portal

Top soil health monitoring is essential for promoting sustainable and climate resilient agricultural practices and optimum usage of water resources. Soil Health Card portal has been developed by NIC to facilitate centralized generation and monitoring of Soil Health Cards. Fertilizers Recommendations are worked out for Fruits and Vegetable Crops based on crop stage/age helping farmers adapt to ever-changing climate and soil nutrient cycles. National Soil Health Dashboard has been created for scheme monitoring and generation of Soil Health Card Maps. Some of the other activities are fertilizers assessment, Generation of nutrient status reports, Migration of data from State portals to National Portal and Database optimization. Portal has been integrated with Land Records for Andhra Pradesh, Karnataka, Uttar Pradesh, Haryana and Himachal

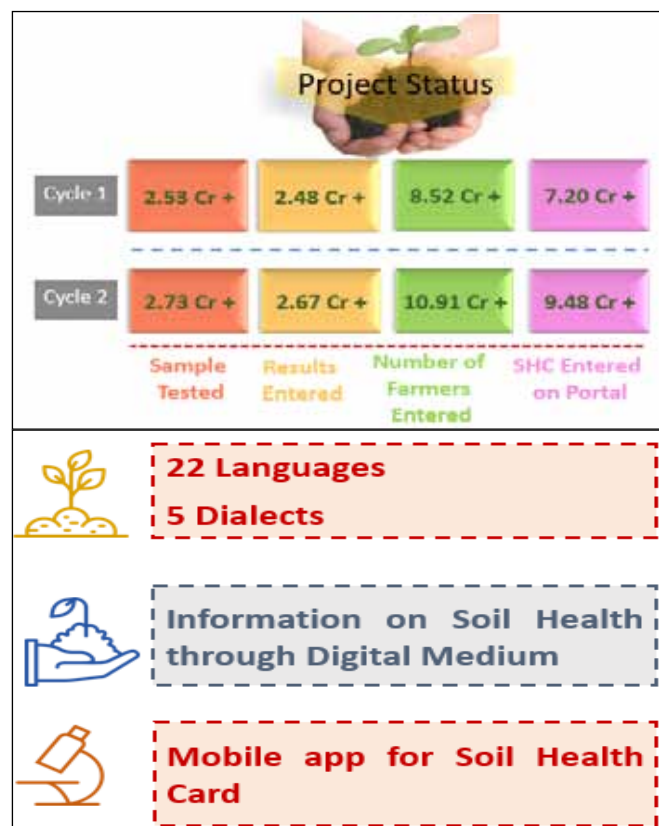

2.3.1.2 PM Kisan- Pradhan Mantri Kisan Samman Nidhi (PM-KISAN)

NIC has developed a Centralized PMKISAN portal (<https://pmkisan.gov.in>) for direct benefit transfer under the Central Sector Scheme, “Pradhan Mantri Kisan Samman Nidhi (PM-KISAN)”. PM Kisan Portal facilitated instant disbursal of funds to large number of farmers while providing assessment tools for monitoring the progress of the scheme and transaction details at all levels. Various modules are farmer registration through direct entry and bulk uploading, account validation and lot creation: Request for fund transfer (RFT)/ Fund transfer order (FTO) module, correction windows for data rejected at various levels, dashboards and reports, beneficiary tracking, self-registration by farmers and approval by States, Aadhaar Authentication and user management. This has benefitted more than 6 crore beneficiaries of India.

Training through e-learning and Help-desk support is being provided. PM-KISAN has received the ‘GEMS of Digital India Award 2019’.

2.3.1.3 Integrated Fertilizer Management System (iFMS)/ DBT in Fertilizers (eUrvarak)

eUrvarak(iFMS), a technology solution developed by NIC for the scheme "Direct Benefit Transfer in Fertilizers" to ensure adequate and timely availability of fertilizers in the country. It aims to manage fertilizer subsidy disbursement by the Department of Fertilizers and covers all functionalities in entire supply chain for capturing transactional data starting from procurement of raw material, production of fertilizers, imports at different ports, movement from plant and ports by rail or road to district warehouses in accordance to the monthly supply plan, sales from district to wholesalers and from wholesalers to retailers. POS based application enabled with Aadhaar based biometric authentication is used to capture fertilizer sale from 2.25 lakh retailers to farmers. The system

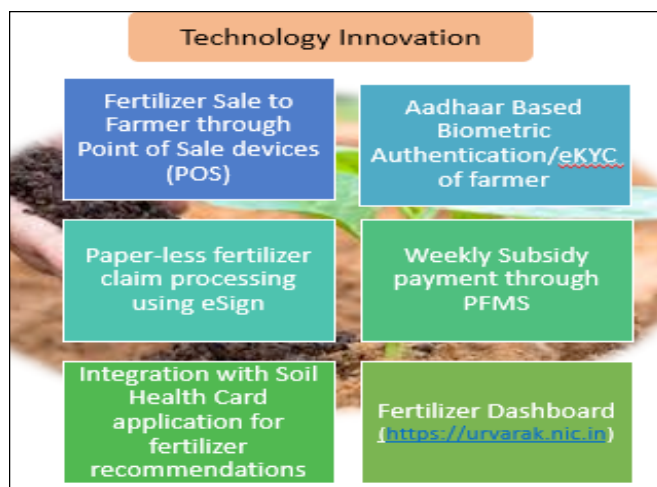

is used to calculate subsidy amount of different types of subsidy claims, with an estimated yearly outlay of Rs. 74,000 crores and further processing for payment to fertilizer companies through PFMS. As per data available with DBT Bharat Portal, “DBT in Fertilizers” saved Rs. 10,000/- crore on Fertilizer subsidy during 2018-19.

2.3.2 Health & Family Welfare

2.3.2.1 e-Hospital

As part of the Digital India initiative of Ministry of Electronics and Information Technology, NIC has developed the cloud-based e-Hospital, e-Blood Bank and ORS applications.

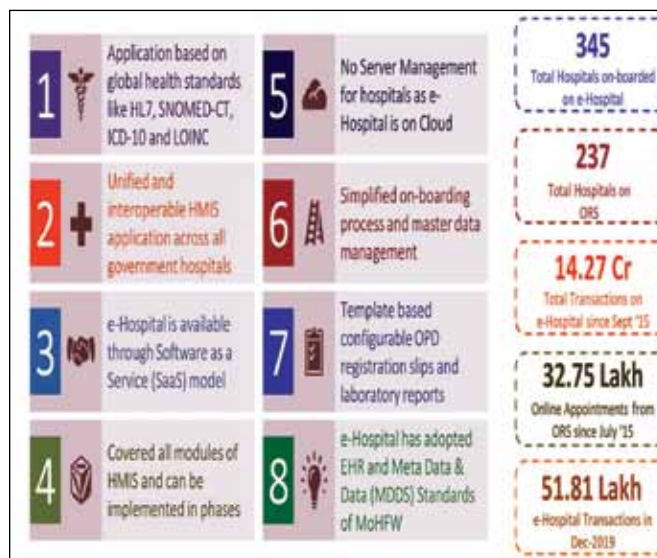

e-Hospital system is a one-stop solution which connects patients, hospitals and doctors on a single digital platform. The modules of e-Hospital which are currently available on cloud are Patient Registration (OPD & Casualty), IPD (Admission, Discharge & Transfer), Billing, Lab Information System (LIS), Radiology Information System (RIS), Clinic, Dietary, Laundry, Store & Pharmacy, OT Management along with ORS and e-Blood Bank. ORS (<https://ors.gov.in>) is the online patient portal for booking online appointment and for providing patient centric services like viewing lab reports, checking blood availability status and making online payment.

2.3.2.2 Beneficiary Identification System (PM-JAY)

Beneficiary Identification System (BIS) is a process to apply and approve entitled beneficiaries on the Socio-Economic Caste Census (SECC), Rashtriya Swasthya Bima Yojana (RSBY) database and State databases. Aayushman Bharat - Pradhan Mantri Jan Arogya Yojna (ABPM-JAY) aims to target about 10.74 crore poor, deprived rural families and identified occupational category of urban workers' families as per the latest Socio-Economic Caste Census (SECC) data and all active enrolled families under RSBY. It consists of approx. 50 crore target beneficiaries to be identified through BIS. BIS has been integrated with Aadhaar, SMS, e-Mail and States APIs for data of 10 States (PDS, Samagra and State Health Insurance Beneficiaries, etc.). PM-JAY e-Card is printed and handed over to the beneficiary to serve as a proof of verified beneficiary to get health insurance benefits under PM-JAY. The benefits can be availed in NHA empaneled hospitals for approved Medical Packages. 7 crores+ PM-JAY beneficiaries have been identified and issued e-Cards using BIS. 91% of which have been identified using Aadhaar.

2.3.2.3 Central Government Health Scheme (CGHS)

CGHS software has been developed to facilitate Central Government employees to avail better health services. Online appointments can be booked from home for desired doctor for specific date and time. Doctors can prescribe medicines and convey instructions for pharmacists to disburse medicines. Complete transparency is maintained by triggering SMS updates for every medicine handed over to beneficiary. Online QR code based mobile app has been developed for CGHS beneficiaries to submit their feedback on defined CGHS services. Self-printing of CGHS Card has also been facilitated. It also features Automatic Purchase Order placement without human intervention for 272 medicines at Wellness Centres. On transfer of Government Servant, online transfer of CGHS card to any of the CGHS cities for serving beneficiaries has been facilitated.

429 Wellness Centres have adopted CGHS application. 35.80 Lakh Beneficiaries have been benefitted through CGHS system. Total 12.13 CGHS Card Holders are onboarded in the system. Total 5.89 Lakhs CGHS cards have been printed.

2.3.2.4 Reproductive & Child Health (RCH)

Reproductive & Child Health (RCH) is an augmented version of Mother and Child Tracking System. RCH application tracks individual beneficiaries and provides them services and facilitates service record capturing and monitoring at all levels (National, State, District, Block, PHC and Sub Centre level). Application facilitates timely delivery of all components of antenatal, postnatal and delivery services of Pregnant Women, complete immunization services to children and family planning services to eligible couples. 19.45 crore eligible couples have been registered with RCH. 17.83 crore pregnant women have been registered with RCH. 15.28 crore children have been registered

with RCH. 15.72 Lakh health workers have been registered with RCH.

2.3.2.5 Direct Benefit Transfer - Health (DBT)

DBT Health portal enables States/UTs to maintain and track DBT related progress and generate consolidated reports for Ministry. DBT Health Portal has been integrated with DBT Bharat portal. Total 9 schemes have been on boarded and integrated on DBT Health Portal. These include Janani Suraksha Yojana, ASHA Incentives, Payment to Contractual Staff, Family Planning Compensation, Janani Shishu Suraksha Karyakram, NIKSHAY – TB Patient Incentive for Nutritional Support, NIKSHAY – Tribal TB Patients, NIKSHAY – DOT Provider Honorarium, NIKSHAY – TB Notification Incentive for Private Sector.

2.3.2.6 CollabDDS

CollabDDS (Collaborative Digital Diagnosis System) provides a real time collaborative environment to visualize medical (Skeletal) and dental images (digitized X-Ray images or DICOM data) for radiological diagnosis and treatment planning. Doctors at remote location can also collaborate using CollabDDS to discuss critical radiological cases. Further, it can also be used for two way or multi-point session between different Medical Colleges for educational purposes.

CORS (CollabDDS Online Radiological Services) provides a web interface to different health communities for resolution of radiological and dental issues. CORS is accessible to local as well as remotely situated doctors for seeking guidance from expert radiologists. Using CORS, doctors can either upload cases for forwarding to experts or can conduct real time collaboration with the experts, thereby reducing the turnaround time. As a part of implementation, 8 Centers Of Excellence or Regional Resource Centers (RRC) selected under (NMCN) who are going to be the First level

of Centers. Currently 79 hospitals are registered in CORS with approximately 550 registered cases.



Indicleft is a web-based tool that captures approximately 350 parameters for patients with cleft-related diseases. This tool provides an interface for doctors from different disciplines like Orthodontics, ENT, Plastic Surgery, Genetics, and Psychology to enter different parameters related to cleft patients. Indicleft has been successfully deployed at ICMR data centre. Indicleft has been extensively used by doctors from different centres like namely AIIMS, New Delhi, KGMU, Lucknow, GSR, Hyderabad, and MMCH, Guwahati. Till now more than 700 cases have been registered.

2.3.3 Finance

2.3.3.1 Public Financial Management System (PFMS)

PFMS aims to develop an integrated digital finance network of Central, State Governments, and the agencies of State Governments. It plans to provide a financial management platform for all plan schemes, a database of all recipient agencies, integration with core banking solutions of banks handling plan funds, integration with State Treasuries, and efficient and effective tracking of fund flow to the lowest level of implementation for plan schemes of the Government.

Integration has been done with the Banks/India Post who are authorized to collect Small Saving Schemes deposits from customers for daily monitoring of deposits/withdrawal from saving

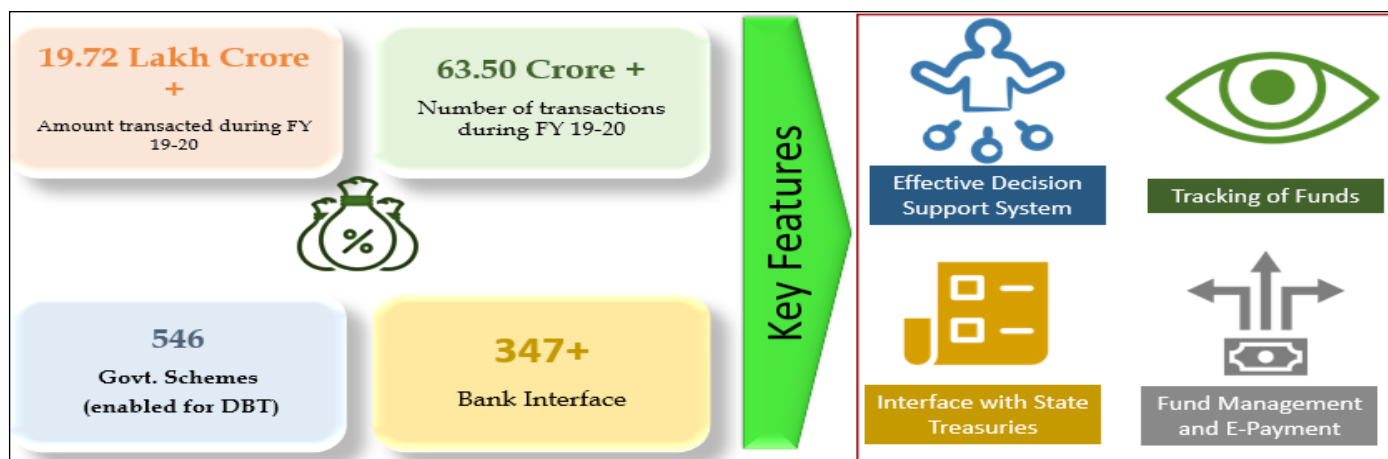

schemes and maturity pattern of deposits. Advance and Transfer (EAT) modules, provisions have been made in PFMS for all the concerned authorities to prepare scheme components for the next financial year through the user interface.

In National Tax Revenue Portal (NTRP) Module, implemented UPI payment mode, Enabled NEFT/RTGS payments for Line of Business Application (LOBA), Integrated NTRP with Umang application through web service to provide the receipt information collected through NTRP, Provision of selling of Supreme court Book/Magazine. Seven new ministries/departments are on-boarded on NTRP.

2.3.3.2 e-Way Bill

e-Way Bill (EWB) mechanism is put in place to ensure that goods are transported in accordance with GST laws and tax is paid for the supply of goods. e-Way Bill is an electronic document which gives details regarding the movement of goods and needs to be carried by transporters for any consignment exceeding Rs.50,000. The application, developed by National Informatics Centre (NIC), facilitates operations on e-Way Bill through multiple modes like Web, Mobile, SMS, API and Offline tool.

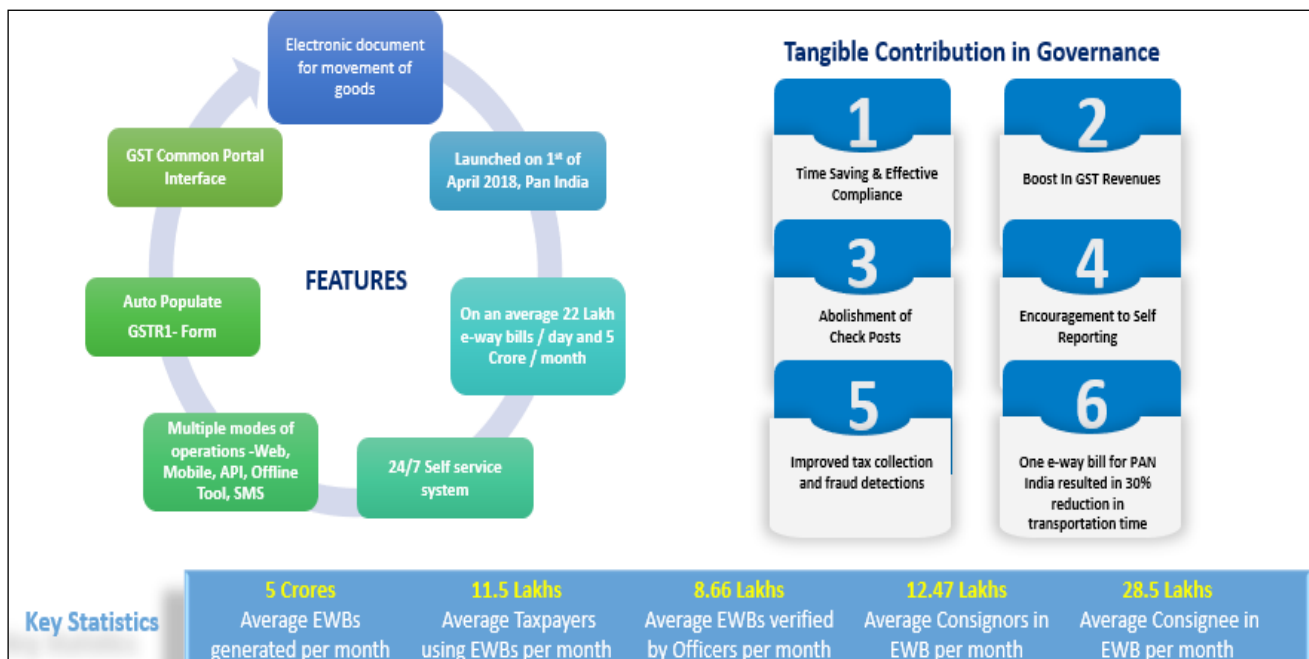

Through e-Way Bill system, Taxpayers, Transporters and Tax officers accomplish all work within a unified system hence conforming to the Unique Selling Proposition (USP) of Goods and Services Tax i.e. “One Nation... One Tax... One Market... One e-Way Bill...”

2.3.3.3 GST Prime

An online system for processing of back-end activities related to GST system. This has been designed, developed and implemented in-house by NIC, Bangalore for Commercial Taxes Department (CTD), Karnataka. GST-Prime is a product to help the tax administrators to analyze and monitor the tax collection and compliance within their jurisdiction. GST-Prime improves the GST compliance, increase the tax collection, increase the tax base, detect the tax evasion and fraud and predict the effect of policy change. It has been successfully implemented in Karnataka and recently being implemented in, Chhattisgarh, Jharkhand, Himachal Pradesh and Haryana. It is under implementation stage for few more states. GST e-Invoice System is designed for B2B, B2C (High value) and Export type of transactions and more than 50 Lakhs tax payers are expected to use the system per month basis.

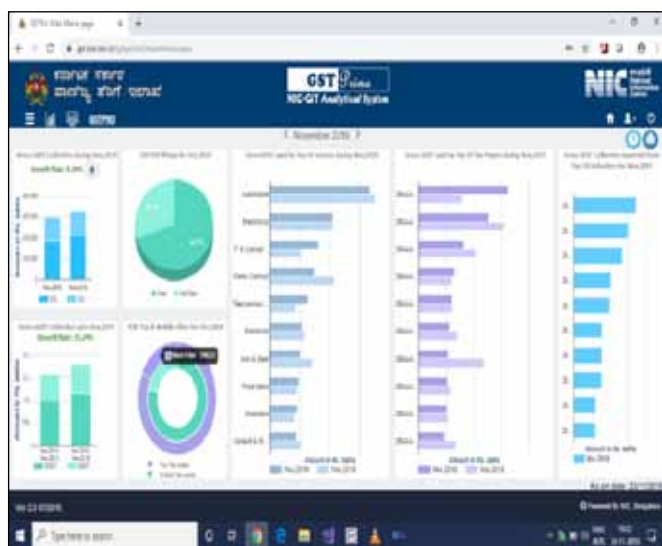

GST Prime

2.3.3.4 Indian Customs EDI Systems (ICES)

The ICES Application took giant strides towards achieving the highest standards in “Ease of Doing Business” in international trade. The Single Window Interface for Trade (SWIFT), was implemented successfully which would reduce interface with Governmental agencies, dwell time and the cost of doing business. The objectives of SWIFT are in line with two key programmes of Government namely ‘Make in India’ and ‘Digital India’. The basic idea behind this concept is Exponential improvement in Ease of Doing Business and Radically fast Customs clearance of imported goods. The benefits accruing to the international trade community include Virtual Customs assessment of Imported goods, Customs clearance at Port of Import, Changes in IGM for faster clearance, Cash Ledger for faster Duty payment, Post clearance compliance, SMS and E-mail alerts to stakeholders at various stages etc.

Various other modules at various stages of development / implementation are Digitally signed copies of Bill of Entry / Shipping Bills, Automated queuing of Facilitated BES, JSON based Data download facility, API based interface with Participating Govt. agencies, International AQ certificate exchange with BENELUX countries and Partial Re-credit of Bonds. As a recognition of the efforts done by the ICES Team, the ICE-DASH – The EODB (Ease of Doing Business) Dashboard has been recently launched by the Hon’ble Finance Minister.

2.3.4 Education

2.3.4.1 E-Counselling

NIC e-Counselling services provide web enabled solution to academic institutions/bodies across the country for examination management, counselling and admissions. Services cater to all the stakeholders namely, aspirants, examination boards, counselling board, participating institutions and reporting cum document verification centres.

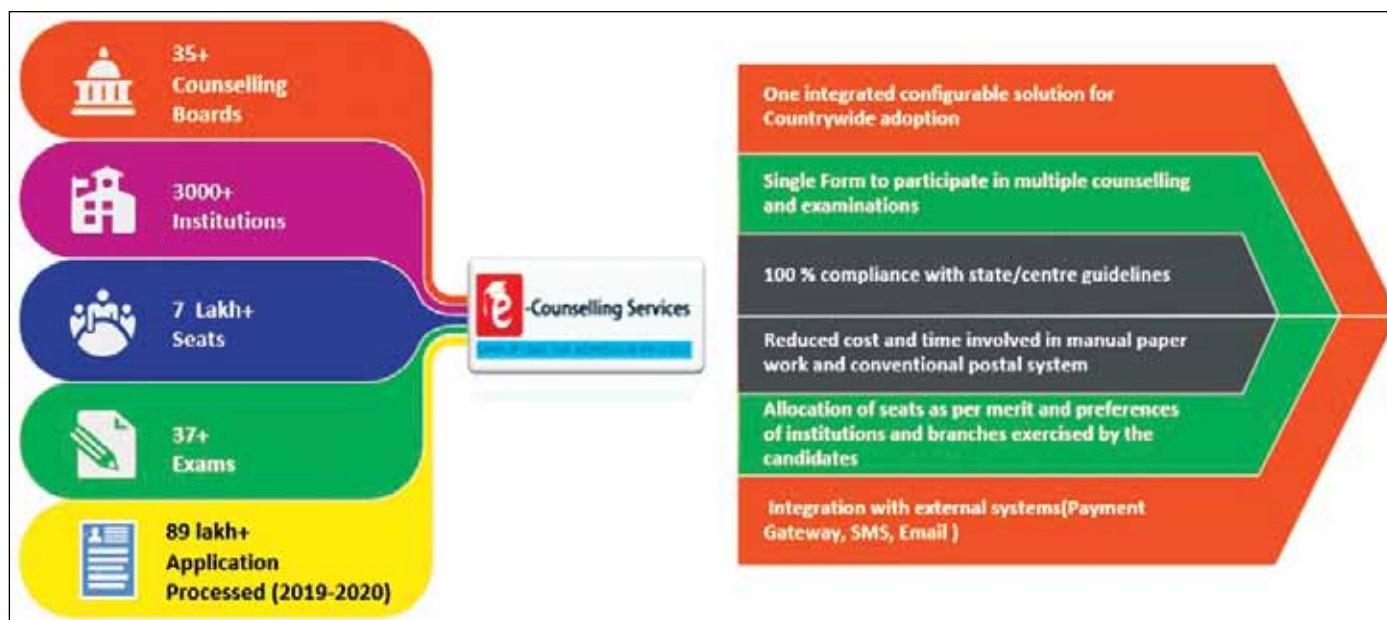

End-to-End technical services/solution are provided for conducting more than 37 examinations by assisting premier organizing bodies and other institutions such as NTA, CBSE, UP, WB, Odisha, etc. NIC has been instrumental in partnering with various examination bodies in conducting central and state level examinations such as JEE (Main/Advanced), NEET, UGC National Eligibility Test, and Central Teacher’s Eligibility Test (CTET). In addition to this, it caters to counselling services for counselling boards across India for admission to premier institutions such as IITs, NITs, IIITs and Central/State funded universities/institutions in various domains like engineering (Degree, Diploma, ITI), medical, architecture, pharmacy, agriculture, hotel management, etc. catering to candidates from 8th/10th pass to Post Graduates. It has been conferred with Gems of Digital India Award 2019(Jury’s Choice) for software excellence in e-Governance.

2.3.4.2 National Scholarships Portal

National Scholarship Portal is a one stop solution for end to end scholarship process right from submission of student application, verification,

sanction and disbursement to beneficiaries for all categories of scholarships provided by the Government of India and states as well. It encompasses various Scholarships schemes launched by Union Government, State Government and Union Territories across the country. This initiative aims at providing a Simplified, Mission-oriented, Accountable, Responsive & Transparent 'SMART' System for faster & effective disposal of Scholarships applications and delivery of funds directly into beneficiaries account through DBT without any leakages.

National Scholarship Portal works through the seamless integration of the activities of diverse entities: students, colleges, departments, IT service provider, banks and treasury and 18 Ministries/ Departments. NSP has won “Governance Now Digital Transformation Awards, 2019” in the category End to End Digital Services (G2C), by Governance Now.

In the Academic Year (AY) 2018-19, total of 10 Central Ministries/Departments & 7 States have on-boarded their 59 scholarship schemes with 1.5 crore applicants, 69 lakh recipients and with

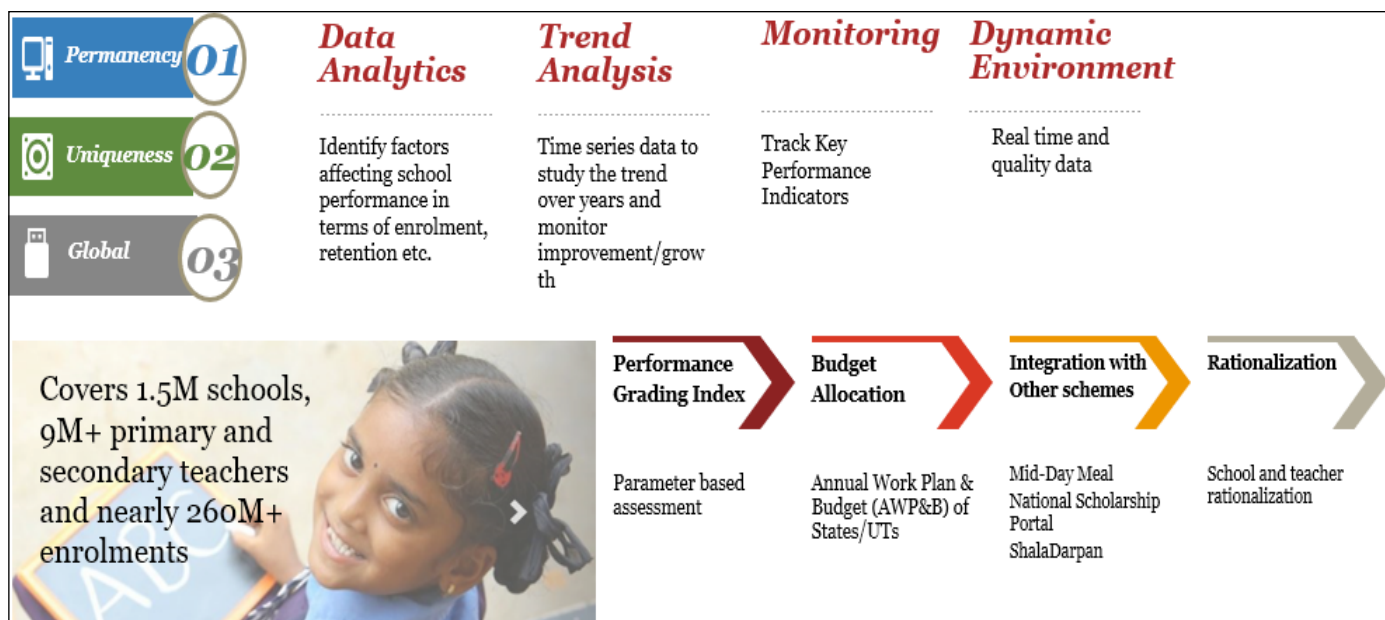

disbursement of Rs. 2165 crores. The scholarship processing is underway for the current Academic Year 2019-20.

2.3.4.3 UDISE+: Unified District Information on School Education

UDISE+ is an annual survey conducted to create a sustainable Educational Management Information System for schools by capturing essential parameters regarding infrastructure, finance and accounting, faculty, students, geo-location etc. It has emerged as an integrated junction for citizens of the country to acquire contemporary and credible facts for the school education system. It has drastically improved the quality and credibility of the data provided. UDISE+ has been awarded Gems of Digital India Award 2019 (Analyst’s Choice) for excellence in e-Governance, SKOCH Platinum Award 2019 and SKOCH Challenger Award 2019.

All the schools enrolled in the UDISE database are allotted unique codes called UDISE code and are used by various departments/applications for identification and record maintenance for each school. Some of them are National Scholarship portal, School GIS, NGOs, Central/State education

boards, Shagun, Performance Grading Index, Vidyanjali etc.

2.3.4.4 AISHE-All India Survey on Higher Education

All India Survey on Higher Education (AISHE) has emerged as single source of truth for higher education sector providing an all-inclusive spectacle of Higher Education in the country. It provides year-on-year trends in the key performance indicators for the sector. All the major Stakeholders in Higher Education such as University Grants Commission, All India Council for Technical Education, Medical Council of India and the State Governments participate in data capturing exercise. Survey is a web-based solution with a dedicated portal <http://aishe.gov.in> providing role based administrative rights to users spanning across ministry, state, district and end user level thus making the exercise completely paperless. Data is being collected on several parameters such as teachers, student enrolment, programmes, examination results, education finance, infrastructure etc. Sustainable development pointers for education sector such as Gross Enrolment Ratio, Pupil Teacher Ratio, Gender Parity Index etc. are calculated from the

data collected through AISHE. It plays crucial role in making data backed policy decisions and research for development of education sector.

In the survey conducted in the year 2019, data was captured for 38179 colleges, 962 universities and 9190 standalone institutions. All the institutions part of higher education network received enrollment of around 37.4 million applicants for various courses with 48.6% being female candidates.

2.3.4.5 Mid-Day Meals Automated Reporting and Management System (MDM-PRMS)

In order to efficiently manage the enrolment and meals being served in the Schools of various States under the National Programme of Nutritional Support to Primary Education (NP-NSPE), the MDM-ARMS software has been developed as a product so that any State Education Department can use it. The data collected is reflected on the National Portal on daily basis.

The MDM-ARMS application provides a standard generalized, cost-effective, Toll-free SMS-based, easy to use/on-board and effective monitoring solution to users. 17 State/UTs who have adapted the system are Himachal Pradesh, Assam,

Chandigarh, Chhattisgarh, Haryana, Madhya Pradesh, Meghalaya, Mizoram, Nagaland, Rajasthan, Telangana, Daman & Diu, Uttarakhand, Tripura, Dadra and Nagar Haveli, Jammu & Kashmir, Arunachal Pradesh. The backend software is used for storing location, school profile, teacher details, reason for non-serving, student/teacher attendance, alerts, monitoring tools, direct entry of meals data, graphical reports, interfacing with the mobile app, GIS reports etc.

2.3.4.6 ShalaDarpan

ShalaDarpan has been developed as an integrated platform to cater to data requirements for complete school education ecosystem of the country. The vision of ShalaDarpan is to leverage technology (mobiles, tablets, web-based applications) to enable data collection in streamlined manner with aims to fulfill data needs of school education in the country. It also seeks to provide a common platform that will unify all the digital systems at the Central and State level. This will improve accessibility of data, promote standardization, and enable data usage to improve efficiency, create transparency and enhance accountability in system. All these changes will invariably result into improved student learning outcomes in longer run.

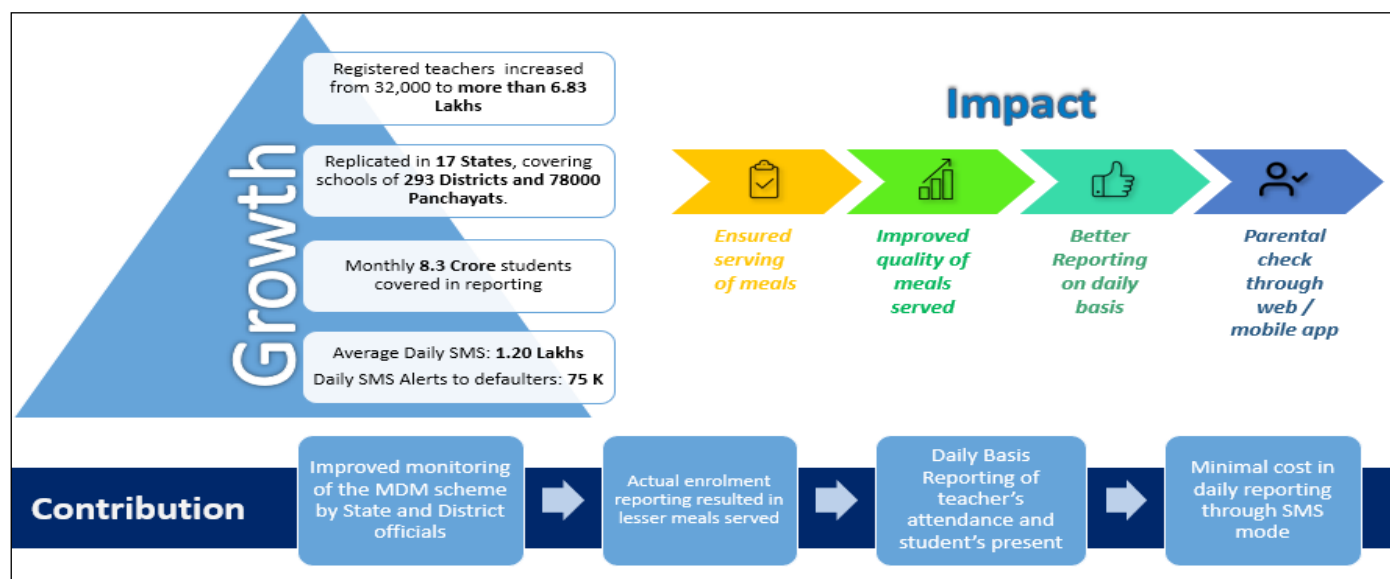

Screenshot from MDM-ARMS Software

Therefore, a holistic platform that caters to the entire value chain of the major stakeholders like students, teachers and school management is required, while resolving of existing issues. Platform acts as a junction for data needs of all stakeholders in the school education system. It facilitates the transition from a paper-based system to a complete digital system. School management and sector governance have been enhanced by streamlining processes, creating transparency and driving accountability. Complete support is provided for improving student learning outcomes.

GIS enabled portal to monitor the location of all schools across the country at central level and STS (Karnataka), Shala Darpan (Rajasthan), SARAL (Maharashtra), E-Vidyavahini (Jharkhand) etc. at state level. It is with this recognition that MHRD envisions ShalaDarpan as a decentralized platform where states will have the flexibility to determine the level of integration of the existing systems based on their requirements.

2.3.5 Transport

Transport Sector has seen phenomenal progress in terms of process automation, IT enablement, process re-engineering etc. – at both Central and State levels. Vahan 4.0 is a centralized one stop solution for services like vehicle registration, permit, tax payments, fees payments. It has been running successfully for 1185 RTOs across the country with registration of over 25 crore vehicles. Sarathi 4.0 offers various services like issuance of driving license, learner license and international permit. It has offered a digital solution for issuance of 15 crore licenses across 1157 RTOs across the country.

2.3.5.1 eChallan

A comprehensive traffic management solution using a mobile-based app and complimentary web application. It is Integrated with CCTV/ ANPR (Automatic Number Plate Reading) Cameras,

RLVD/OSVD (Red Light/ Over Speed Violation) Devices, Later Guns etc for issuance of challan/ notices. Web interfaces have been developed for enforcement/police officials, RTOs, higher officials, transporters as well as citizen along with integration with Smart City System in various states.

Nation-wide data sharing has been facilitated for traffic violations across states. History of past offences, automatic identification of frequent offenders is recorded and monitored. There is provision for spot challan & settlement facility through cash, card, PayTM, UPI and other options. Citizens can pay for challans “anytime and anywhere”. Portal offers speedy and efficient disposal of challans through integration with Virtual Court. There are integrations with back-end data sources like Vahan, Sarathi, PUCC, NCRB, IRDA etc. It ensures ease of use, almost-zero paperwork, real-time access to back-end vehicle and license data, automatic calculation of penalty amount and so on. Ensures better compliance of traffic rules, lesser errors through integrated online system. Project was awarded Gems of Digital India Award 2019.

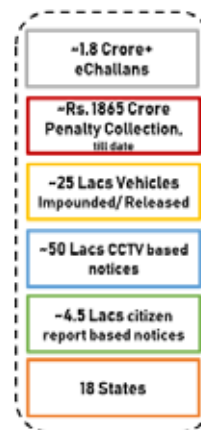

2.3.5.2 mParivahan

mParivahan is a Citizen Centric Transport Solution- primarily a mobile-based app for citizens and transport operators providing access to all transport services related to driving license, vehicle registration, taxation, fitness and vehicle permit.

The app is applicable across the country, covering all DL & RC holders, and its key stakeholders are citizens and enforcement agencies. Engineering a 180-degree shift in the earlier process, i.e. saves the citizens from the hassle of carrying physical documents/ cards, for verification/ inspection/

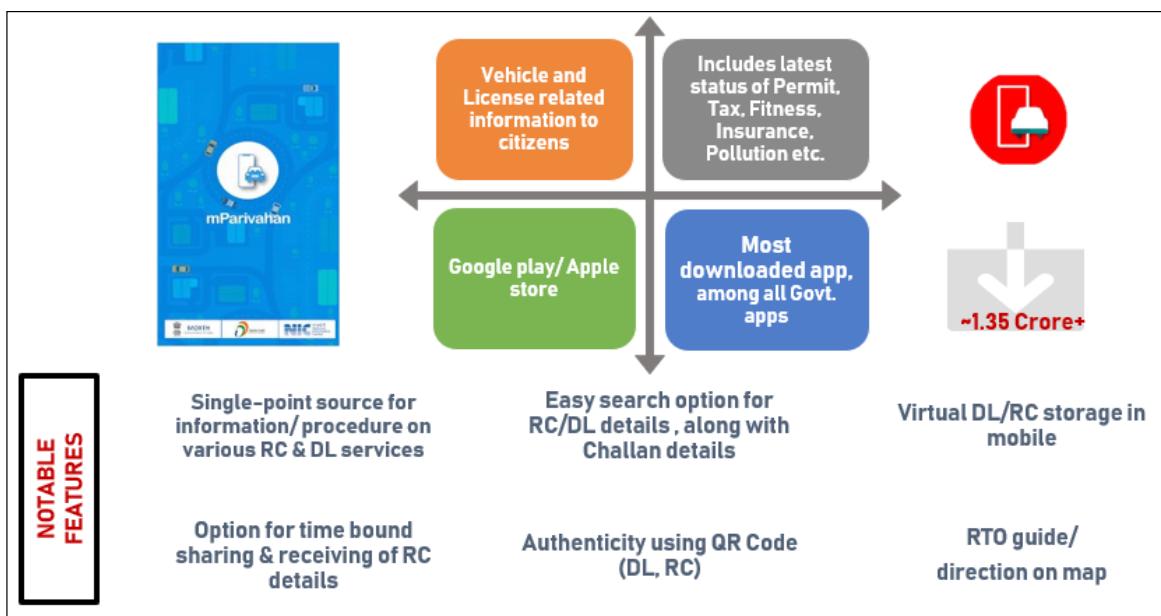

offence filing related purposes - Virtual DL/ RC are now acceptable. It is integrated with other databases (eChallan, Vahan, Sarathi) for sharing/receiving data through APIs.

The mobile app provides features like Virtual RC/DL Certificate in place of paper-based documents, tracing RTO/Traffic Office Locations, QR code-based authentication etc. services. Additionally, a web-based platform is provisioned for Analytics, MIS, Reports, etc. requirements of various stakeholders. Available in both Android and iOS platforms. It has 4.6 ranking on Google App store with 1.35 Crdownloads. There are Options for online reporting by Citizen – for Traffic Violation and Road Accidents.

2.3.5.3 PUCC (Pollution Under Control Certificate)

Pollution Under Control Certificate (PUCC) application is centralized, web-enabled application for testing and certification of vehicular emission. It caters to the Pollution Check Points across the country and enables issuance of PUCC, as well as updates National Database with Pollution compliance status as per MoRTH notification and Hon'ble Supreme Court guidelines. It comprises a single database and single-core application having configurable option to address inter-state variations in the work flow, fees structure, output formats, payment modes and so on. Integrated with Transport National Database for verification of technical parameters Citizen can avail the PUC Certification process in a transparent and

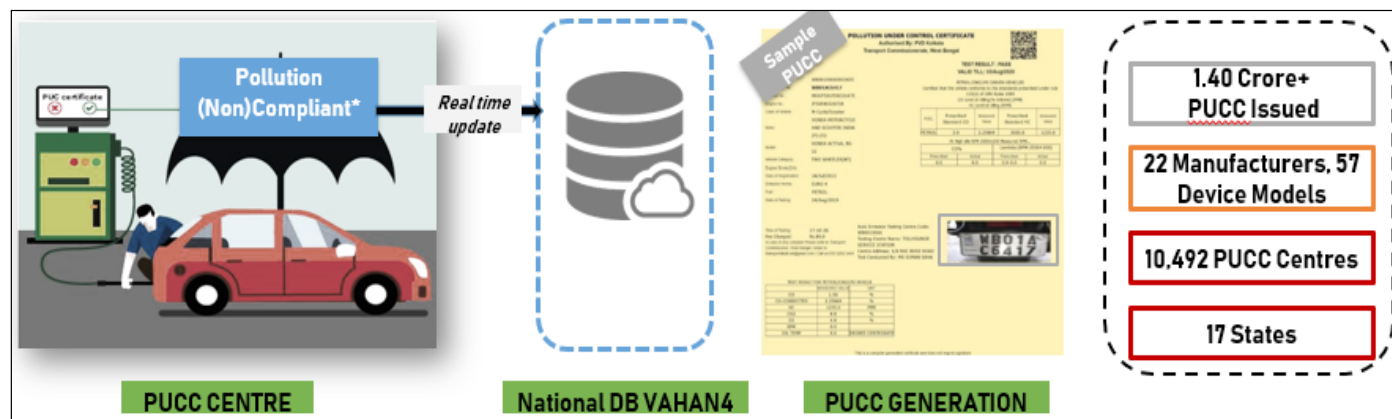

tamper-proof manner. Certificate is stored in Central system and status is reflected in National Register, DigiLocker, mParivahan etc.

Malpractices involved in manual process have been replaced by automated reading, analysis, approval and certification by machine. PUC Operators can register online, pay fees through ePayment mode. Transport Department can approve and monitor centres – convenience to users, bringing transparency & efficiencies in the system. It caters to a large number of stake holders like ARAI, Device manufacturers, PUC stations, citizens apart from the core user base of RTO/ Transport Department staffs.

A large bouquet of digital payment options (Net Banking, Card Payment, PoS Payment, etc.) have been incorporated in PUC 1.0 as per state's requirements

2.3.6 Inclusive Development

2.3.6.1 Swachh Bharat Mission

Rural

The Swachh Bharat Mission (Gramin) was launched by the Hon'ble Prime Minister of India for eradicating the practice of open defecation across the country by 2019. The nation was declared as Open Defecation Free (ODF) by him, on Swachh Bharat Diwas (2nd October, 2019). The mission led to the construction of more than 10 crores household toilets. As an outcome, 36 States/UTs, 699 Districts, and 599,963 villages were also declared ODF.

The name-wise database of beneficiaries with parameters like name, category, sub-category, etc. of around 17 crore households was captured using SBM (G) online digital platform. Along with this, the details of 11 crore toilets built under SBM program, with photograph and geo-codes of the toilets have also been captured. The KPIs have been modelled around the main aim, which is, sustaining the gains of the SBM-G and ensuring sustained access

to safely managed sanitation in all rural areas as well as focussing on achievement of a clean-living environment through solid and liquid waste management.



The digital platform related to SBM-G and ODF Plus integrates the SBM-G web portal, online monitoring application, mSBM mobile App, SwachhApp citizen mobile App, Swachhata Hi Seva (SHS) 2019, Swachhata Action Plan, Sujal Swachh Sangraha Portal, Swachhata Darpan, all Event portals like Swachh Shakti, Swachh Survekshan Grameen, Swachh Bharat Diwas, etc. The concept of Always On availability Group clustering mode helped in providing uninterrupted services for the digital platform. The mobile applications contributed to the campaign where other digital devices such as webcams, desktops could not fulfil the purpose. Geotagged photographs were captured using an easy-to-use intuitive interface. Map Services have been consumed used to provide dynamic pictorial representation of ODF status and geotagged images on the map.

Urban

The Government of India is implementing 'Swachh Bharat Mission Urban' (SBM(U)) since October 2, 2014 with the goal of achieving a Clean India by 2nd October 2019. As part of this engagement, NIC developed a portal "swachhbharaturban.gov.

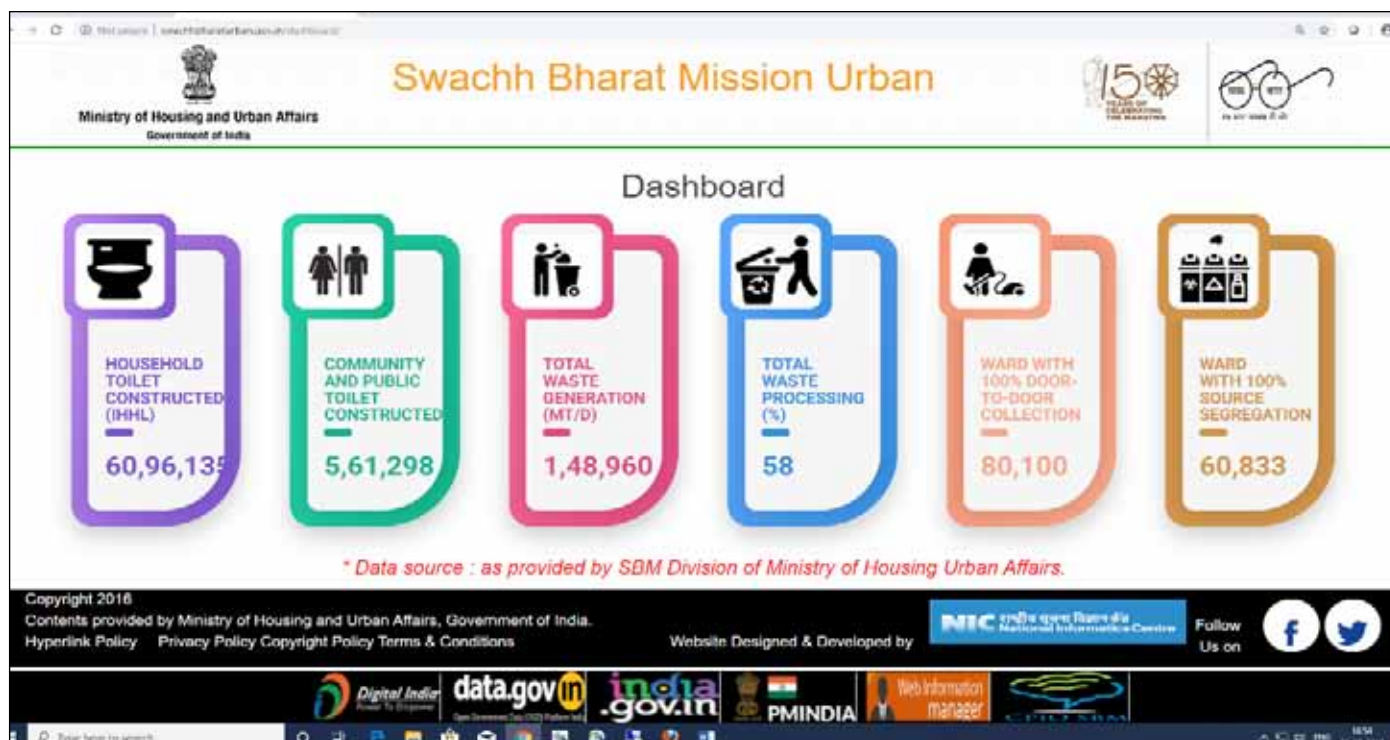

in” to monitor and track the sanitation progress of all 4000+ ULBs and 8000+ wards of India and to provide complete online support for construction of approx. One crore individual House Hold latrines (IHHL). Portal also Capturing the data of various components (CT, PT, SWM, Swachh Survekshan, ODF rating, GFC ranking etc.) and Monitoring the status of sanitation activities of all ULBs and Wards.

SBM(U) Portal is a one stop portal which gives access for submission, verification, Approval of application for IHHL and transfer of subsidy to beneficiaries in their bank account. Various mobile apps made available to all stakeholders (National Mission Directorate, State Mission Directorate, Urban Local Bodies, Wards, Beneficiaries) as well as to Citizens for effective execution of Swachh Bharat Mission Urban.

Services are rolled out to user through various mobile apps like Toilet Locator, SWM Treatment Plant App for KARVY, mSBM App, Geo Tagged Photo App, Offline Geo Tagged Photo App, mSBMUrban Dashboard, IHHL Application Status, Swachhalaya,

IHHL Verification, AI enable mobile app SwachhAL. Application is integrated with Secretary Dashboard, CM Darpan and Ministry’s website. Largest online digital survey “Swachh Survekshan” is carried out every year to award swachh ranking to each city.

2.3.6.2 Pradhan Mantri Adarsh Gram Yojana – PMAGY

NIC implemented the <http://pmagy.gov.in> in 2019-2020 for the physical and financial monitoring of PMAGY scheme. Scheme aimsintegrated development of the selected villages with more than 500 village population and more than 50% SC populationto provide basic infrastructure and services in the villages. The portal facilitates the district nodal officer to digitize the village level and household level survey for the generation of Village Development Plan (VDP). Infrastructural and individual oriented physical and financial progress enables the village to achieve the benchmark score for declaration as Adarsh Gram. An extensive

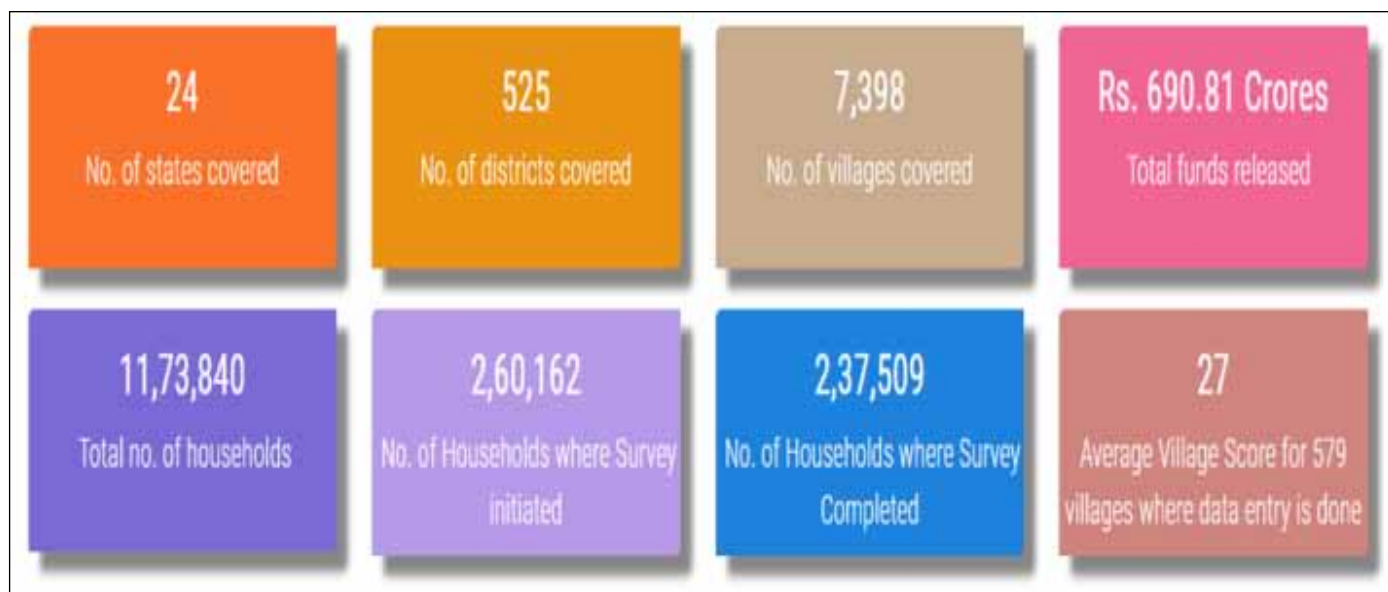

Progress Dashboard is made available with drilldown reports up to district level. 7,398 villages are currently being covered.

2.3.6.3 Mahatma Gandhi National Rural Employment Guarantee Act (MGNREGA)

MGNREGA is one of the largest employment guarantee schemes in the world. NREGASoft is an end to end work flow-based e-Governance application designed and developed in collaboration with Ministry of Rural Development, GOI. The software covers all the activities from MGNREGA MIS to Citizen centric App and training modules to end users. Since NREGASoft MIS captures all the activities under MGNREGA scheme, it processes approximately 1 crore Transactions per day including around 10-12 lakhs financial transactions related to Wage, Material and Admin payments. MGNREGA scheme caters to 691 districts, 6,921 Blocks and 2,62,631 Gram panchayats.

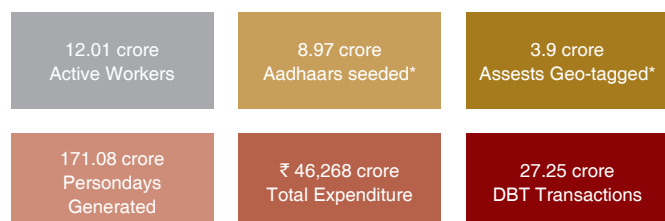

In the last one year, due to multiple IT interventions MGNREGA has achieved 96.97% timely payments generation. Further, to increase transparency all work assets under the programmes are being geo-tagged and time-stamped, using ISRO’s Bhuvan platform. Analytics and GIS based planning is now making it possible to better identify areas and works that need focus under the programme. Another step taken in direction of transparency, financial and technical estimation that were manually done till last year have been automated and use the State specific Schedule of Rates for estimation through the new integrated application – SECURE (Software for Estimation Calculation Using Rural rates for Employment). SECURE also increases the accountability since it is a complete workflow system requiring approvals from the respective authorities for all estimates calculated based on unit rates compared to earlier process where the capture and approval was only of the lump sum amount.

2.3.6.4 National Generic Document Registration System (NGDRS)

Digitization of the document registration system (governed by registration act 1908) has been taken

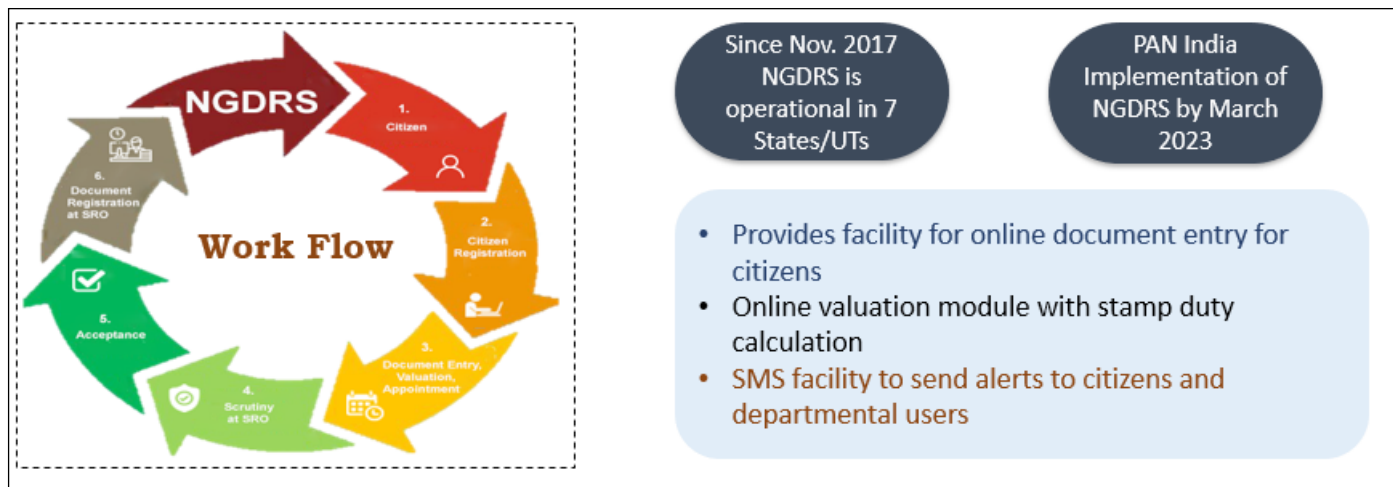

under Digital India Land Records Modernization DILRMP Programme. Development of national generic document registration system application addresses the diversity and variations in document registration across states and union territories because of languages, processes, formulae and formats. It fulfills the need of ONE NATION ONE SOFTWARE which can cater to all the states and union territories requirements. While the application was built, there was a need of providing a holistic view of the document registration system, its capabilities to deliver the services from different viewpoints and to provide standards and guidelines to manage and enhance the solution built.

2.3.7 Food and Public Distribution

2.3.7.1 Targeted Public Distribution System

The Public distribution system (PDS) is an extensive food Security System established under the Ministry of Consumer Affairs, Food, and Public Distribution. The System is operated under the shared responsibility of the Central and the State Governments. The scheme envisages to provide efficient and transparent system and create an ecosystem for the delivery of beneficiary-centric and qualitative PDS services to more than 81 crore beneficiaries across the country on a digital platform.

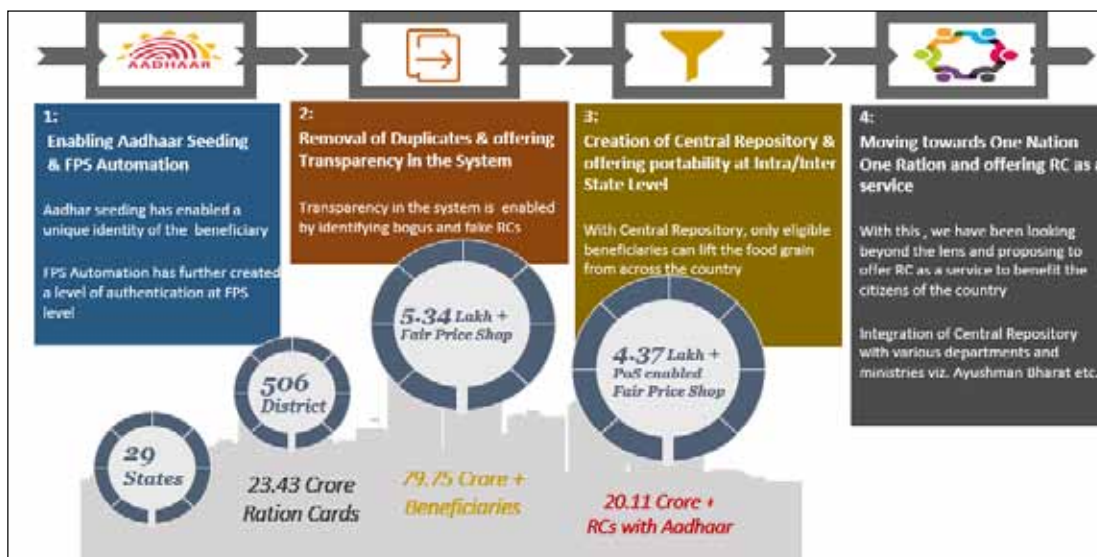

As part of the Digital India initiative, NIC have developed various applications for Digitization of beneficiary data (RCMS), Computerization of Supply Chain Management (FEAST), Setting up of Transparency portal and Grievance Redressal mechanisms (NFSA, ANNAVITRAN etc.).

2.3.7.2 Computerization and Computer Networking of Consumer Fora in the country (CONFONET)

The scheme of 'Computerization and Computer Networking of Consumer Fora in the country, (CONFONET)' aims to digitalize the functioning of the Consumer Fora at all the three tiers throughout the country to enable access of information and quicker disposal of cases established under the Consumer Protection Act, 1986. The project is extended as a sub scheme of Consumer Protection Scheme with a layout of Rs. 79.88 crore for CONFONET exclusively for 2017-20.

Through the portal <https://confonet.nic.in>, consumers have easy access to accurate and dependable information regarding cause lists, judgments, case status and case history. Quick search facility using case number, complainant name, respondent name etc. and free text search for judgments is also available. The Online Case Monitoring system has been fully implemented & operational at NCDRC, all State Commissions and more than 600 Consumer Forums including few clubbed DCFs. More than 19 Lakhs cases have been updated on Central Server. Various services for consumers/public like Case Status, Case History, Cause Lists, Judgments, Display Board, Pull SMS have been developed. Dashboards have been developed for administrator and public. IVRS and CHATBOT facility have been introduced to know the Case Status.

2.3.8 Law & Justice

2.3.8.1 eCourts

An application for Judiciary, Case Information System (CIS) is developed and implemented in High Courts and District & Sub-ordinate courts in the country. Currently CIS version 3.1 is

implemented in District & Sub-ordinate courts and CIS HC Version 1.0 is implemented in 21 High Courts in the country. Data from all these courts are replicated in real time to the NIC Data Centre at New Delhi.

National Judicial Data Grid (NJDG) <http://njdg.ecourts.gov.in>, a consolidated nationwide judicial data warehouse was set up with real time updation. NJDG provides statistics of pending and disposed cases in the country. It works as monitoring tool to identify and manage the pendency of cases. This information can be used by management authorities for policy making and decision support.



Citizen centric services like Case Status, Cause lists, Orders/Judgements, SMS etc. are provided using eCourts portal <http://ecourts.gov.in>, eCourts Services Mobile App(Available on both Android and iOS platforms) and JustIS App for Judicial Officers.

Unique 16 Character Case Number Record (CNR) is created for each case. Automated SMSes and emails are triggered to Advocate/Litigants on case events. It is integrated with CSC's, UMANG, ICJS etc. eCourts portal is GIGW compliant and differently-abled friendly. Metadata and Data Standard (MDDS) are used for standardized information exchange within the application.

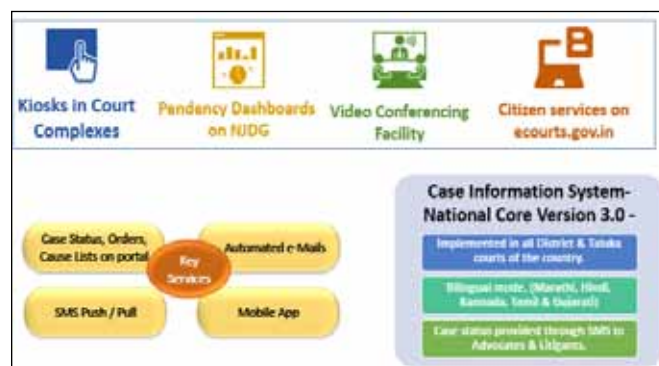

2.3.8.2 eGovernance Support to Supreme Court

Website for Supreme Court of India is hosted on NIC Cloud providing benefits of scalability and extensibility for managing inbound traffic. Website is integrated with content delivery network for faster and unlimited concurrency handling ensuring availability of recently delivered Judgments (Ayodhya, Sabrimala, Rafael, CJI office under RTI Act etc). It is available in nine vernacular languages other than English (Hindi, Tamil, Telegu, Kannada, Bengali, Marathi, Punjabi, Gujrati, Malayalam). Litigants and Advocates specific platform independent Mobile App has been developed in Nine Vernacular Languages which was inaugurated by Hon'ble The President of India.



2.3.8.3 National Tribunal

2.3.8.3.1 National Green Tribunal

NGT with the help of NIC has initiated **NGTOnline Portal** to enrich public awareness on the clean and green environment by publishing various Govt. Initiatives/ acts/ notifications on the portal and to facilitate IT based effective and paperless Grievance Redress System through digitization of various processes. The software has three modules viz. E-Filing, Case Information System and Document Management System. NGTOnline has been developed under the aegis of Ease of Doing Business, keeping in mind the concept of completely paperless courts for efficient G2C services and optimum use energy and natural resources. Digitalization of courts and digitization of the filing system has reduced consumption of

paper for different purposes. Ver 2.0 of NGTOnline has been implemented in all benches offering a Complete paperless solution.

2.3.8.3.2 National Company Law Tribunal

National Company Law Tribunal (NCLT) with the help of NIC has initiated Online portal for filing petitions/applications/documents and to facilitate IT based effective and less-paper Grievance Redress System through digitization of various processes.

Portal has led to ICT enablement of National Company Law Tribunal by Automating judicial functions. Records are digitized and preserves in digital medium significantly reducing the required storage space. Process Re-engineering for excellence in delivery has made the system user friendly and transparent.

Paperless court has been launched at NCLT Principal Bench, New Delhi and New Delhi Bench in January 2019. Metadata capturing has been completed for Mumbai, Jaipur, Chandigarh and Allahabad bench till November 2019.

2.3.8.4 Virtual Courts

A novel concept of virtual courts has been introduced under the eCourts project. The concept is aimed at reducing footfalls in the courts by eliminating the physical presence of violator or advocate in the court. Virtual court can be managed by virtual judge whose jurisdiction can be extended to entire state and working hours may be 24x7. Neither litigant need to visit the court nor judge will have to physically preside over the court thus saving precious judicial time.

A Virtual Court was inaugurated in Delhi on 26th July and in Haryana on 17th August to initially try Traffic Challan Cases. The Virtual Court concept will reduce the pendency of cases tremendously, considering the large number of traffic offences and offences under local and special laws.

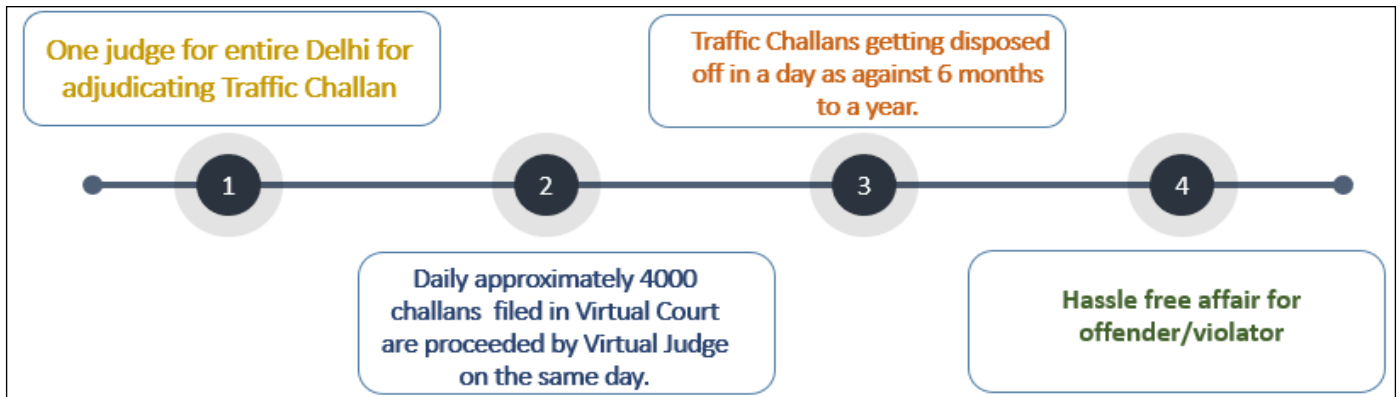

Number of judges required for adjudicating traffic challans across the state can be reduced virtually to single judge. eChallans to be submitted in the court are automatically filed to the virtual court for adjudication. Virtual Judge can access the Virtual Court application from anywhere, view the cases and adjudicate the cases online.

2.3.9 Home Affairs

2.3.9.1 Interoperable Criminal Justice System (ICJS)

ICJS is interoperable Criminal Justice System. ICJS involved key pillars of Criminal Justice System such as CCTNS (Police), Court, Prison, Prosecution, Forensic, WCD, Track Child etc. It's main objective is to offer 24x7 data availability to all ICJS

Stakeholders by integrating all pillar applications- CCTNS, eCourts, ePrisons, eProsecution, eForensics, Track Child, Arm License.

It enables Interoperability between various pillars of justice system. National Search Dashboard has been created for Police, MHA, law enforcement agencies etc. Analytical dashboard predicts trends in crimes to control criminal activities. 360° Profiling of the persons involved in various pillars is done. Data Exchange is carried out through secure protocols.

Statistics	
Challans Received in eCourts	5.65 Lakh +
Challans in which Proceedings Over	5.64 Lakh +
Challans disposed off	3.24 Lakh +
Fine Collected	46.28 Cr +

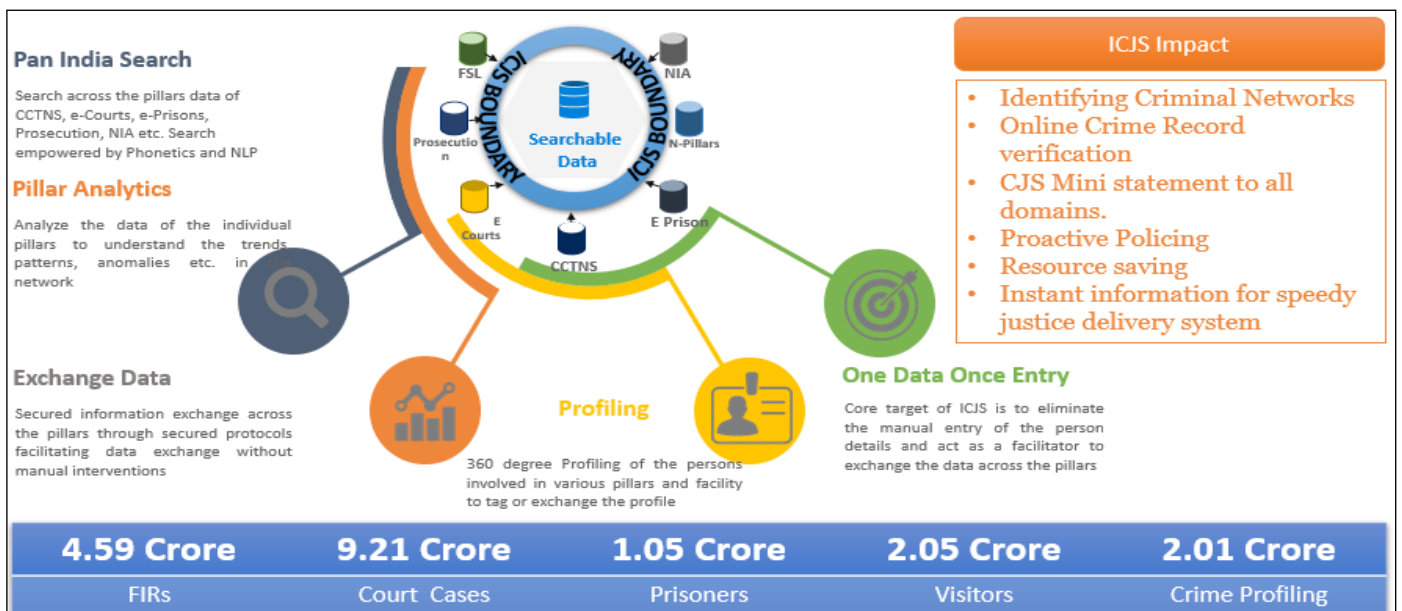

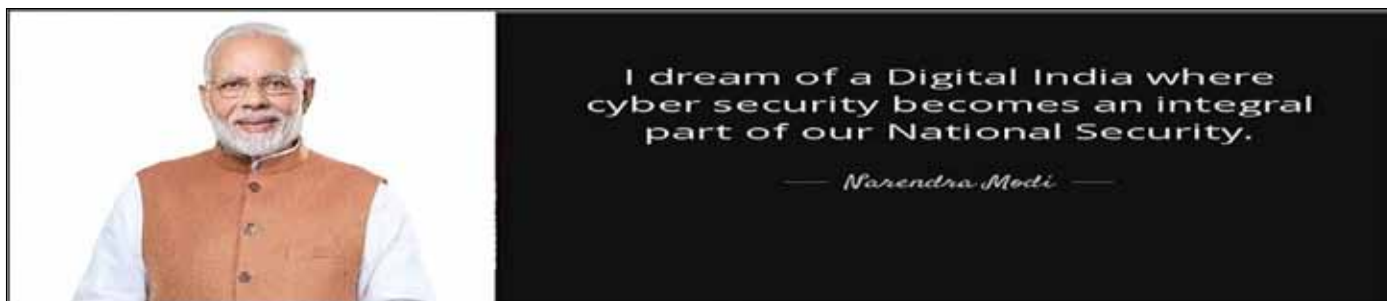

2.3.9.2 National Cyber Crime Reporting Portal 2.0

National Cyber Crime Reporting portal 2.0 facilitates recording of crimes against women and children. Multiple felonies are included namely Child Pornography (CP) Child Sexual Abuse Material (CSAM), Rape / Gang Rape (RGR), Sexually abusive content, Sexually explicit content and other cybercrimes. Complaint reporting can be anonymous or using a mobile number. As per the existing norms, the objectionable contents are to be taken down within 36 hours of receiving the complaint. Once the complaint is submitted, corresponding investigating officer are alerted through SMS and email for immediate attention.

The application also caters to reporting of financial fraud, social media abuse, hacking, online gambling etc. This portal is also integrated with ICJS and CCTNS. Some additional features are

inter dialogue box for police officials, change of jurisdiction mismatch, suspect tagging, complaint tagging, complaint withdrawal and MIS dashboard.

This web portal went live on 30th August 2019 and it is listed as one of the achievements of the 100 days programme of MHA.

2.3.9.3 E-Prisons

ePrisons Suite is a cloud-based application software with easy to use graphical interface and embedded with a comprehensive security feature. This is a unified application for all the states of India where states need to configure state specific parameters.

It has enhanced the administrative capabilities of the Prisons, country-wide digitization of the prison administration, monitoring various activities of the prison, improving the efficiency and productivity of the Prisons.

Features

- Common Application for Prisons Pan India
- Configurable and integrated with ICJS
- End-to-end IT solution for automation
- Biometric based Identification / verification.
- Prisoner Information Management
- Visitor Information Management
- Court Information Management
- Police Intelligence System
- Kiosk Information outlet for Prisoners



Impact

- Online request for Visiting Prisons by wards of the inmates
- VC based meeting with inmates
- Profiling of Criminals
- Alerts to Prison and Police officials
- Cr.P.C.436A Report (Half sentence)
- eCustody Certificate to the Court
- Support to Legal Aid for Prisoners

Coverage	
States	31
Total Jails	1182 / 1452

Coverage	
Visitors Data	2.05 Cr
Cases / FIRs	1.13 Cr
Inmates	1.04 Cr

2.3.9.4 E-Visa

Scheme facilitates international business seekers, medical patients, and tourists to avail Visa on short notice. Faceless, Cashless and Paperless service for foreigners have decreased Visa application processing time. Electronic Travel Authorisation is conveyed to applicant via e-mail within 72 hours of online application. Software aided Passenger profiling is conducted to identify risky travelers and generation of automated alerts. Centralized system has been created for sharing of information across all concerned stake holders. Travelers authentication is carried out at various touch points through intelligent document scanners and biometrics.

Visa-on-Arrival service has been extended to the nationals of South Korea and UAE. e-FRRO Service has been introduced for all Foreigners Regional Registration Offices (FRROs) and Foreigners Registration Offices (FROs) across the country. Dera Baba Nanak (Kartarpur) Corridor project has been implemented with the release of Praksahpurb550.mha.gov.in portal and operationalization of Immigration Check Post.

2.3.10 Social Welfare & Skill Development

2.3.10.1 National Social Assistance Programme (NSAP)

NSAP-PPS (Pension Processing system) is a workflow-based e-governance solution for identification, verification, approval, sanction of new applications and monthly pension processing system. It captures the entire beneficiary profile. NSAP-PPS is integrated with PFMS, UIDAI and NPCI. It manages 3.26 crore of NSAP pensioners out of them 2.78 crore having bank account and 23 lakhs pensioners with postal accounts. Through NSAP-PPS total 14 States process end

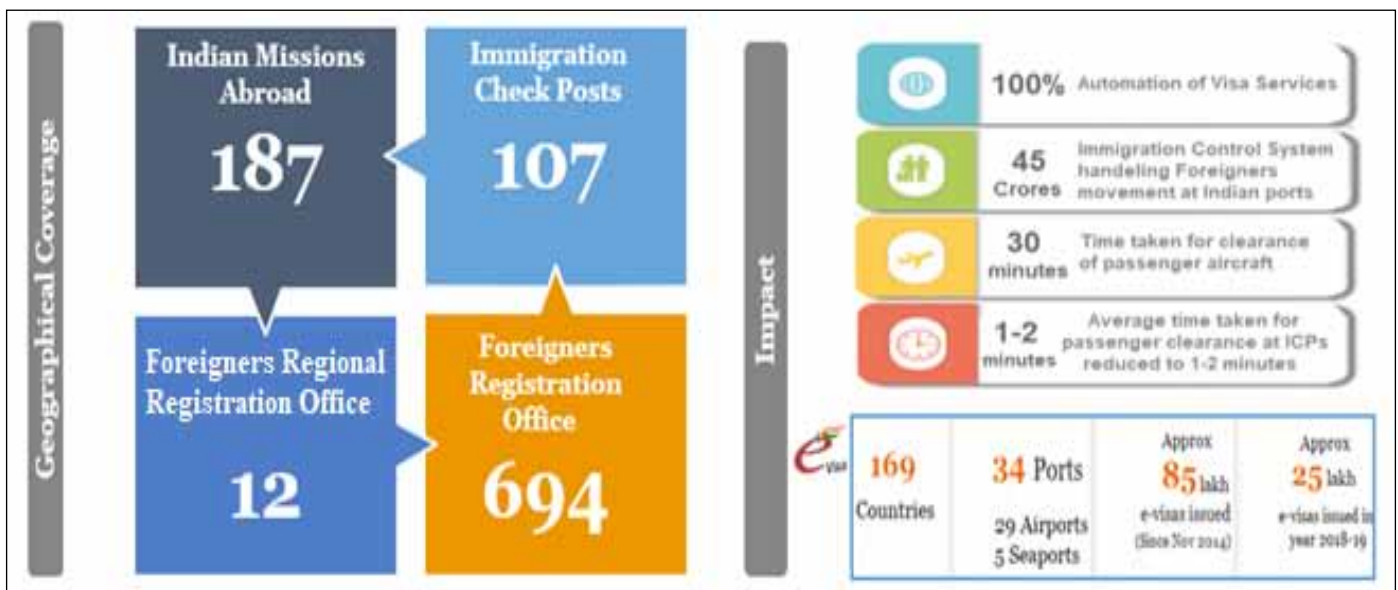
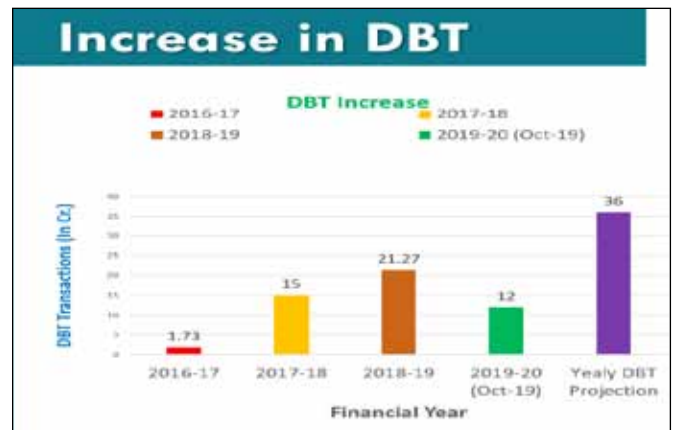

to end transaction and pension to beneficiaries is given directly in their bank/postal accounts i.e. Direct Benefit Transfer (DBT). This has resulted in quick disbursement of monthly pensions to the account of beneficiaries, besides also getting real-time feedback through SMS. To further enhance transparency in the system, the detail of all beneficiaries at GP level under NSAP are displayed in 'Gram Samvad' (rural mobile app). In year 2019-20 approx. 21.26 crore DBT transaction reported on DBT Bharat portal via NSAP-PPS. Total 33 state funded pension schemes have already on-boarded on NSAP-PPS platform.

As per the recent guideline of NSAP, Life certificate using Jeevan Praman has been developed for annual verification of pensioners through Biometric and pilot testing has been completed in state Gujarat and Tamil Nadu.

2.3.10.2 National Overseas Scholarship Scheme – NOS

Every year, applications are invited by Ministry of Social Justice and Empowerment, for National Overseas Scholarship Scheme for Scheduled Caste (SC), Denotified Nomadic and Semi-Nomadic Tribe, Landless Agricultural Laborer and Traditional Artisan categories. Applications are scrutinized as per the eligibility criteria w.r.t grades, age limit, and family income. Scholarships are awarded for diverse fields of study including Engineering and Management, Pure Sciences and Applied Sciences, Agricultural Sciences and Medicine, International Commerce, Accounting & Finance and Humanities & Social Science. Portal developed by NIC facilitates online submission of applications, document upload and verification, scrutiny and subsequent processing by various officials and Screening committee. Entire process involved in the awarding of scholarship is digitized with role-based access rights provided to all stakeholders.

2.3.10.3 National Rural Livelihood Mission (NRLM)

Core application covers the details of all Community Based Organizations (CBOs) i.e. Self Help Groups (SHGs), Village Organizations (VOs), Cluster Level Federations (CLFs) along with Community Cadre Profiles (CCPs) and Capacity Building activities. This also covers the process-based module for Funds Disbursements to all CBOs in addition to important features like managing master data at the local level, LGD Code seeding, Aadhaar seeding and details of core staff and Mission Management Units involved in the ground level implementation of the scheme.

Near about 59 lakh SHGs along with 6.44 crore Members details, 2.33 lakh VOs, 17,600 CLFs, 2.57 lakh CCPs profiles are being maintained. In addition to the above, NIC has also developed an application to manage the interest subsidy component of the Mission which is being disbursed to SHGs who have taken loan from Banks for some livelihood activity and who are repaying it as per the schedule prescribed by the respective Bank. NIC is also coordinating the applications developed for Startup Village Entrepreneur Program (SVEP) and CBO Transaction system, which records the transactions of above-mentioned CBOs, which meet at regular intervals, during which all the financial transactions among the members and the CBOs takes place.

2.3.11 Good Governance & Enforcement

2.3.11.1 E-Office

eOffice is a digital workplace solution with the vision to achieve Simplified, Responsive, Effective and Transparent paperless working in Government office by providing convenient way for officials to access information related to every aspect of their working and knowledge sharing by presenting a single gateway to information and services. The eOffice product is a suite of applications comprises of File Management System (eFile), Knowledge

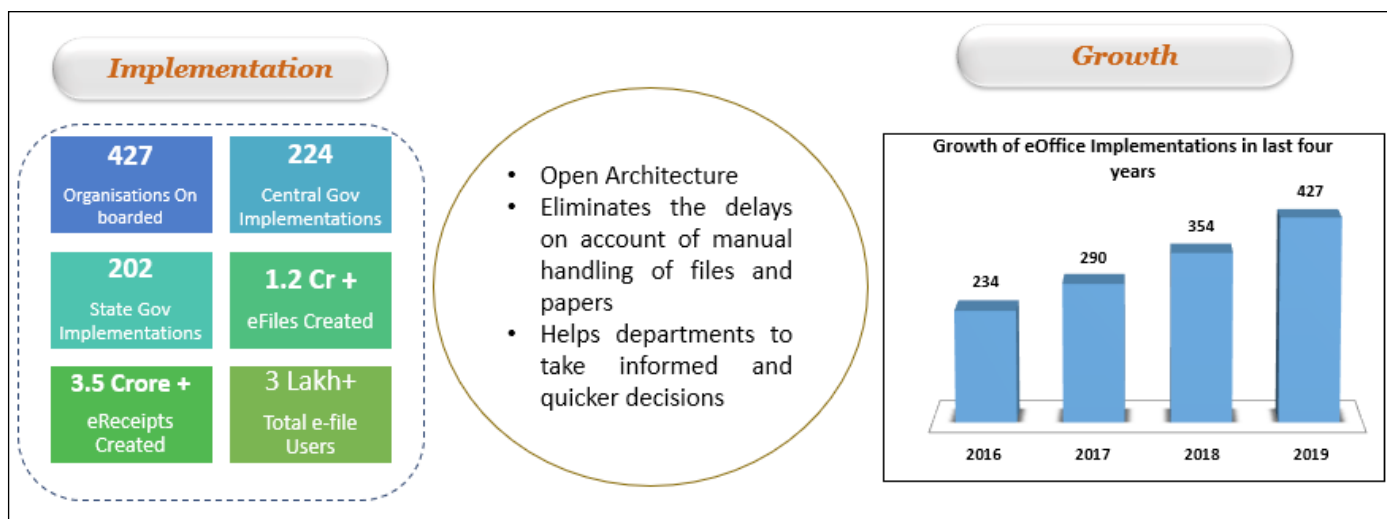

Management System (KMS), Leave Management System (eLeave), Tour Management System (eTour), Personnel Information Management System (PIMS), Collaboration and Messaging Services (CAMS), Smart Performance Appraisal Report Recording Online Window (SPARROW), and Property Related Information System (PRISM).

Applet free digital signer service was released for both eOffice and SPARROW which are SSO (Parichay) enabled. System is integrated to audit the electronic files by the auditor. Letter of Appreciation/ Testimonials were received from various eOffice implementing organizations, namely, Central Water Commission (CWC), Government of Telangana, Survey of India (SOI), Lal Bahadur Shastri National Academy of Administration (LBSNAA), Jawaharlal Nehru University (JNU), Government of West Bengal, etc. Mahabunagar District, Telangana received “Governance Now Digital Transformation Award (2019)”.

2.3.11.2 Service Plus

Service Plus has been developed as part of Panchayat Enterprise Suite (PES) under e-panchayat Mission Mode Project (MMP). It aims to make all Government services accessible to the common man in his locality, through common service delivery outlets. ServicePlus is a unified platform

based on multi-tenant architecture for delivering electronic-services to citizens, an application which is quick to learn and easy to use with minimal effort or very less skill set. ServicePlus provides all types of components and modules one needs to define, configure and commission an e-service. It involves modules like, Service Definition, Service Coverage, Target Beneficiary, Creation of application forms and output certificates, Applicable Service Charges, Work Flow Player’s & tasks mapping and others. SP covers all these modules at the stages like apply, verify, provision and commission required in the process of delivering an e-service as part of Service Life Cycle. It is being used by 5 central departments and 24 states for delivering over 1000 services.

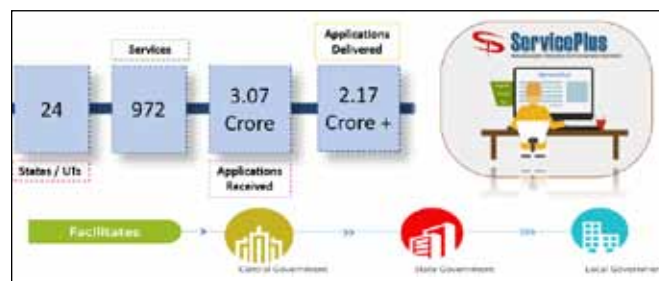

2.3.11.3 Manav Samapada- A tool for Human Resource Management

Manav Sampada is a standard ICT solution for the Government sector, addressing maximum

requirements of State Governments related to personnel management. It is also referred as the eHRMS or the electronic Human Resource Management for Government Departments to help them in taking right decisions at right time and for proper monitoring, manpower planning, recruitments, postings, promotion and transfer based on employee skill sets and State policies.

Manav Sampada” has significantly reduced the delays in service related matters in government Departments. It provides important statistical report like vacancy, staff strength, retiree detail and employee service detail etc. at each level which allows online solution in timely and effective manner. The Lower cost of maintenance, User convenience, Standardization of forms and procedures, Improvement in Carbon-Credit rating by reducing the usage of paper and Multi-channels delivery through mobile phones, web-application (eHRMS-Manav Sampada) and Android/iOS mobile Apps (eHRMS and eTransfer) are additional features of this application.

It has been implemented/under replication in the States of Himachal Pradesh, Jharkhand, Punjab,

Maharashtra, Uttar Pradesh, Bihar, Goa, Assam, Madhya Pradesh, Chandigarh, National Human Right Commission, New Delhi, Chhattisgarh, Gujarat, Mizoram, Uttarakhand, Telangana, Puducherry. Presently, 25 lakh service books are available in the system.

2.3.11.4 Dashboard for Analytical Review of Projects Across Nation (DARPAN)

Dashboard for Analytical Review of Projects Across Nation (DARPAN) Dashboard is a configurable Multilingual product of NIC to transform complex Government data into compelling visuals. DARPAN provide seamless, authenticated and secure integration with user repository through APIs/ Web Services for automatic updates of data on predefined frequency. The single window online solution can be accessed anytime anywhere on heterogeneous devices.

DARPAN is a consolidated dashboard product for Central Ministries and Departments at Central and at State level for Hon’ble Governors, Chief Ministers, Chief Secretaries, Divisional Commissioners and DMs/DCs across Districts.

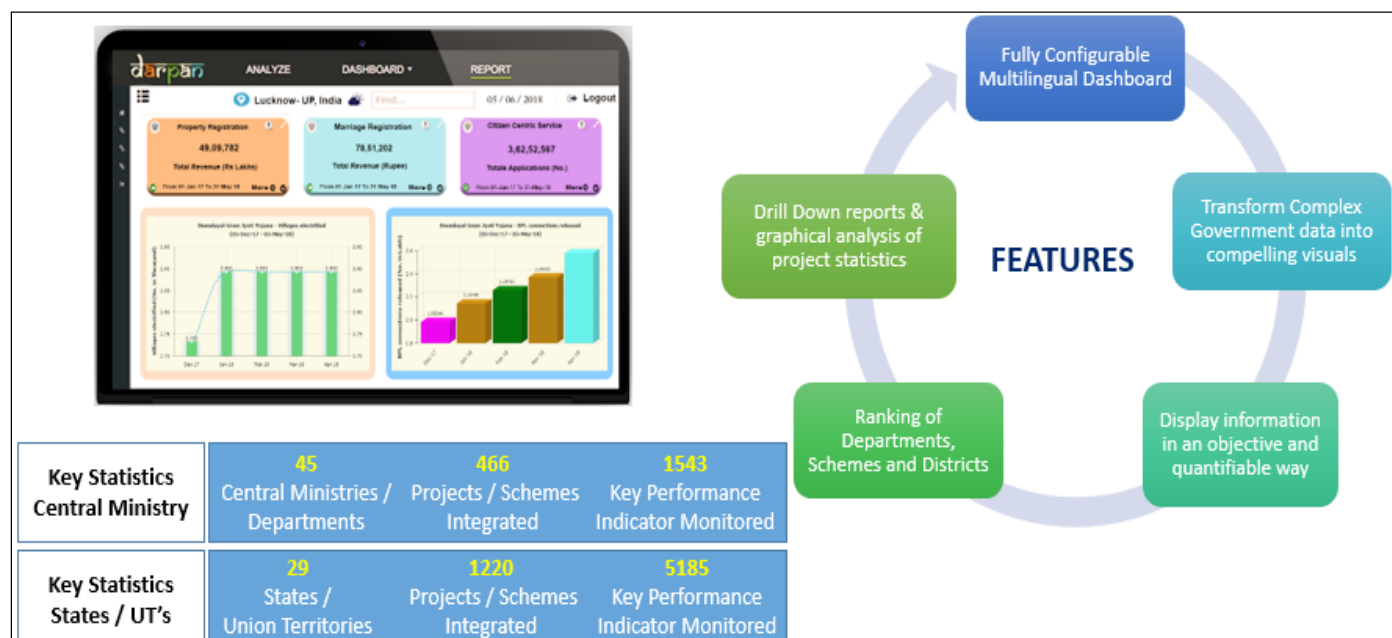



2.3.11.5 Aadhaar Authentication Services

NIC has setup Aadhaar Authentication Services for E-governance Applications of NIC. The services are setup at Shastri Park, Pune and Hyderabad data centers. NIC has redundant leased line connectivity with UIDAI Data centre at Hebbal, Bangalore and Manesar. Aadhaar Authentication services also been extended to the applications hosted in the NIC data Centres. Using the Aadhaar Authentication services of NIC, many projects are being executed like Biometric Attendance System, PDS for Various states, Scholarship etc. Type of Aadhaar Authentication services offered for applications are Demographic Authentication, Biometric Authentication, OTP Authentication and eKYC based on Biometric, OTP. Average response time for authentication is around 1 second and 95% transactions are served within 1 second. NIC is one of the leading transaction requestors for Aadhaar services of UIDAI. NIC has also launched Aadhaar service based on the new framework of UIDAI i.e. Registered Device Concept. All the applications have been migrated to new RD service environment.

NIC has signed agreement with UIDAI to provide AUA/ASA platform for NIC's e-Governance projects. NIC is also rendering the AUA Service on NIC's AUA/ASA platform and is also providing ASA service to requesting AUAs. Presently over 130 State/Central Projects are on board.

2.3.11.6 Jeevan Pramaan

In a big relief to over a crore retired employee of Government and PSUs, with Jeevan Pramaan, a pensioner can now digitally provide proof of his/her existence to the authorities for continuity of pension every year instead of requiring to present himself physically or through a Life Certificate issued by specified authorities. This facility has been widely acclaimed by the pensioners. The Aadhaar enabled biometric digital certification does away with the requirement of a pensioner having to submit a physical Life Certificate in the month of November every year, in order to ensure continuity of pension being credited in the account.

2.3.11.7 Public Grievances

2.3.11.7.1 Centralized Public Grievance Redress And Monitoring System (CPGRAMS)

CPGRAMS is an online web-enabled system developed by NIC, in association with Directorate of Public Grievances (DPG) and Department of Administrative Reforms and Public Grievances (DARPG). It is an integrated platform based on web technology that primarily aims to enable submission of grievances by the aggrieved citizens from anywhere and anytime (24x7) basis to the concerned Ministries/Departments/Organizations/ State Governments and facilitates the departments to scrutinize and act for speedy and appropriate

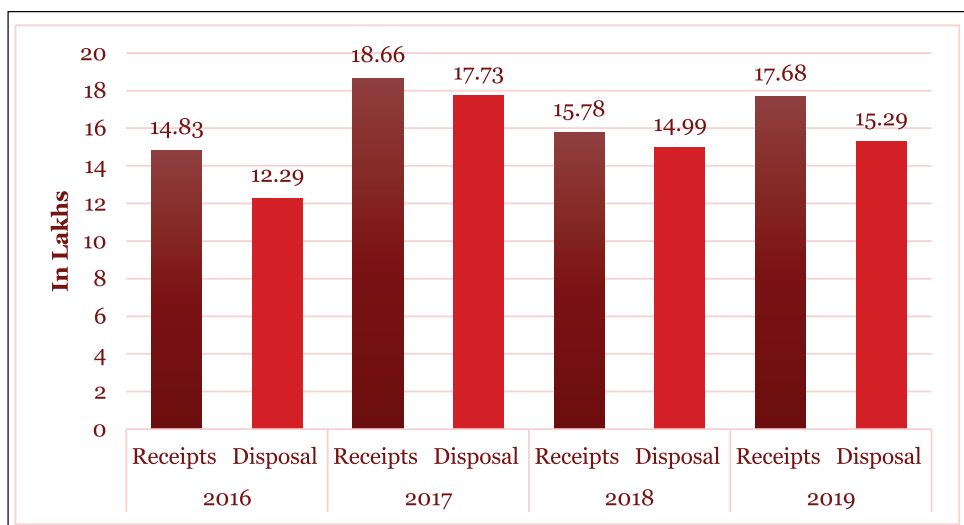

Receipt/Disposal graph of Total receipts in CPGRAMS, as on 08-12-2019

redress of these grievances. Tracking of the grievances is also facilitated on this portal through the system generated unique registration number.

CPGRAMS is receiving more than 18 Lakhs grievances per year and having disposal percentage of more than 90%. The CPGRAMS interlinks 87 Central Ministries/Departments and 37 States / UTs. There are more than 55,000 sub-ordinate users onboard which also includes subordinate and field offices. A dashboard for citizen is provided for easy access. Bi-lingual interface is provided. For Nodal PG officers, bulk closure, parallel transfer, multi forwarding, manage subordinate offices, dashboard, reports on pendency, alert on pending cases, Attachment of Action Taken Report (ATR) etc. are provisioned.

CPGRAMS has been integrated with grievance systems of various states such as Punjab (publicgrievancepb.gov.in), Uttar Pradesh (jansunwai.up.nic.in), Karnataka (espandana.karnataka.gov.in), Jharkhand (cmjansamvad.jharkhand.gov.in), Uttarakhand (cmhelpline.uk.gov.in), Rajasthan (sampark.rajasthan.gov.in) and Jammu & Kashmir (jkgrievance.in) Awaz-e-Awam through web APIs. Other states are coming up for integration. CPGRAMS has also been integrated with grievance system of SEBI viz. SCORES.

2.3.11.7.2 Jansunwayi

Jansunwai (IGRS) (<http://jansunwai.up.nic.in/>) is an integrated application system based on web technology that brings all Grievances Redressal mechanism to one platform. It enables instant and easy communication among the concerned Departments/Officers of the state and citizens resulting in the speedy redressal of grievances on anywhere and anytime basis. More than 1.7 crore references have been registered and out of which more than 1.66 crore have been disposed by the system. Categorization of grievances has been done for each department and is continuously updated by Departments.

Jansunwai is an Integrated Single platform in which different existing forums like CM Janta Darbaar, CM Helpline, Dy.CM Office, DM, SSP, Commissioner/DIG/ IG, State level Departments, Tehsil level Sampurna Samadhan Divas, CSC/Lokvani, Anti Bhu-Mafia, Anti-Corruption, district level call centers and PG Portal have also integrated with it. Additionally, Portal provided the facility to register and track the grievances through portal & mobile app. All grievances are being handled at single platform using uniform Forms for all channels using single username/password.

Citizen can file applications, send reminder and view action taken reports (ATR) by the Government authorities as well as track status online from his home, internet cafe from any geographical location or Kiosks (CSC) established in Districts or through CM Helpline by dialing toll free no. 1076.

Various additional features are:

- GIS dashboard
- Reminder and feedback
- Duplicate complaint identification
- Adaptability, Replicability, Response of the Stakeholders
- Statistical data analysis

2.3.11.8 Swagatam Portal

Swagatam is an initiative by the NIC under “100 Days Programme” of new Government. The main objective of this project is to facilitate the common man for making an appointment with the government officials. It will bridge the gap between the Government and the common man and will

enhance the opportunity of a common man to meet a government officer hassle free. It is an open system and can be adopted by any central / state government.

Swagatam is currently operational at NIC Data Centre, Pune and Hyderabad. Delhi Excise & Entertainment Tax Department is using the swagatam portal. Tripura Secretariat is using Swagatam portal. Bihar, Chandigarh, Punjab, MP are some of the States/UT who have been imparted training/workshop on Swagatam. eVisitors serves the purpose of Temporary passes also where few more documents are added for verification purpose. The system provides a QR coded pass with photograph of the visitor which can be scanned at the entry of the office to enable seamless entry for the visitor. Presently it is being used at 290 Receptions of various Ministry / Departments of the Government of India.

2.3.11.9 Unified Shram Suvidha Platform (USSP)

USSP portal facilitate MoLE and it's Labour Law Enforcement Agencies to monitor the

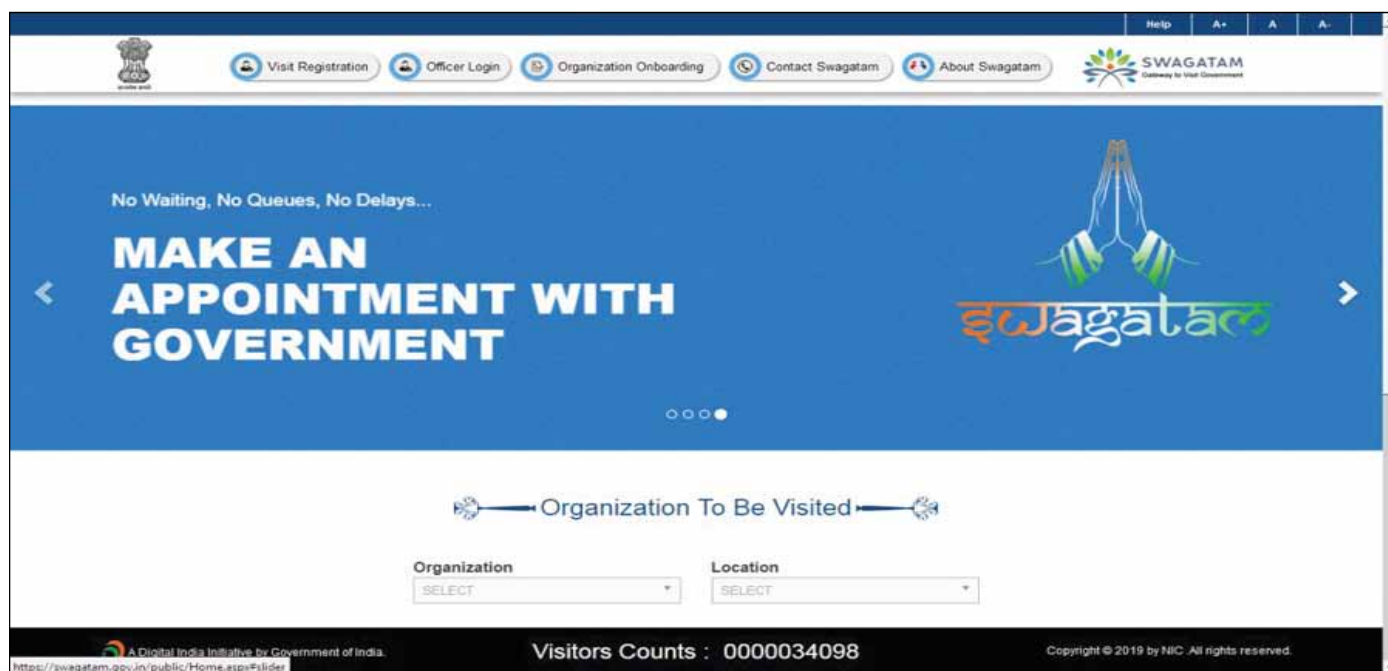

Swagatam - A Gateway to the Government

implementation of labour laws in various establishments in central sphere. It facilitates the employer/establishment to common registration, filing monthly and annual returns under 8 Labour Law along with online common Return under Mines Act. Unique Labour Identification Number (LIN) is allotted to each establishment registered under any labour law after de-duplication of data coming from various enforcement agencies. The USSP Platform provided transparent Labour Inspection Scheme through computerized system on Risk based criteria and uploading the inspection reports within 48 hours by the Labour inspectors. As on 31st December 2019 around 27.95 Lakh LIN are generated, more than 5.44 Lakh inspections are carried out and more than 50 thousand annual returns are submitted. Online Registration under Five Central Labour Acts has been done around 1.46 Lakh and the more than 20800 online Licenses for Work has been granted. Nine State Governments are also on-boarding with Shram Suvidha Portal. LIN Only Regime is being established within various agencies in labour sector.

Common registration service under Five acts for EPFO, ESIC and CLC acts was launched to upgrade the ranking of India under Ease-Of-Doing-Business initiatives.

Common Electronic-Challan cum Return (ECR) service for filling monthly contribution to EPFO and ESIC by employer under Ease-Of-Doing-Business initiatives were launched.

2.3.11.10 Centralized eAuction system

Portal provides a robust platform for conduction auctions in a fair and transparent way. Organisations are on boarded, trained and then facilitated to carry out the auctions themselves. System facilitates Forward Auction, Reverse Auction with Single Lot and Multi Lot Auctions which can be conducted in parallel. Auction Hall is dynamic and is available at the dashboard of auctioneers as well as Auction

Inviting authorities. The system has all security mechanism as available in eTendering portal.

States like Maharashtra, Odisha, West Bengal are using the system extensively whereas few departments of Assam, HP, Puducherry, Jharkhand, Uttarakhand and Haryana etc. are also using the system. The system is also implemented in Central Govt departments like Defences Estates. Auctions were conducted on Sand Mining, Timber Sale, Sale of Property, Sale of Tendu leaves, Sale of Unmilled paddy produce, Unserviceable/ Condemned Item, etc.

It has been noticed that the auctions conducted so far have fetched around 950 % of profit on an average from the base amount.

2.4 Digital Empowerment of Citizens

2.4.1 DigiDhan - Digital Payments

India is at the cusp of transformation towards Digital Economy, enabled by Digital Payments. In the last decade, there have been great advancements in the mobility, internet usage, banking sector, greater enrolments of Aadhaar, evolution of innovative payments platforms and advancements in banking sector accompanied by suitable regulatory guidelines by Reserve Bank of India (RBI) regarding digital banking. Such developments have allowed the payments space to mature, forming the core while building a cohesive ecosystem with enabled services like m-Commerce / e-Commerce, fintech and sector specific integrated services etc.

DigiDhan Mission

In 2017-18 union budget speech, it was decided to set up a mission to achieve a target of 2500 crore digital transactions. Pursuant to this, DigiDhan mission was constituted and a Project Management Unit (PMU) has been set up.

- In order to increase the penetration of Digital Payments Acceptance infrastructure, the

Mission has allocated deployment targets of 20 lakh PoS in Urban, Rural and Northeast sector to 39 Banks in FY 18-19. Also, DFS has allocated target to 35 banks to deploy 20 lakh BHIM Aadhaar PoS devices in FY 17-18, same has been taken forward in FY 18-19 and in current Financial Year.

- In addition, Acquirer Banks have been given target of 1.6 crores merchant acquisition on digital modes (PoS, mPoS, QR, UPI and Wallets etc.) in Rural (Tier III and below) and Northeastern geographies for FY 19-20. Also, it may be noted that in FY 19-20, all the Banks will have to maintain at least 50% of their total merchant base as 'Active' in Urban areas (Tier I & II).
- MeitY extended two incentive Schemes of BHIM namely BHIM Referral for Individuals and BHIM Aadhaar Pay Scheme, till 31st March 2019,

- MeitY further allocated digital transaction targets to Ministries/ Departments based on citizen touch points for each Ministry/Department and its affiliated institutions.
- In order to enhance the awareness level on digital payments modes, its benefits and its enablement process, MeitY regularly participates in training workshops with various stakeholder agencies.
- Digidhan mission is monitoring growth of digital payments adoption in Banks, Ministries/ Departments, States and Smart Cities using Digital payments dashboard (www.Digipay.gov.in). The Dashboard constitutes information from all the 56 banks, NPCI, RBI, DFS and Closed loop PPIs.

Growth in Digital Payments

Over the years there has been a significant growth in digital payments, as indicated below:

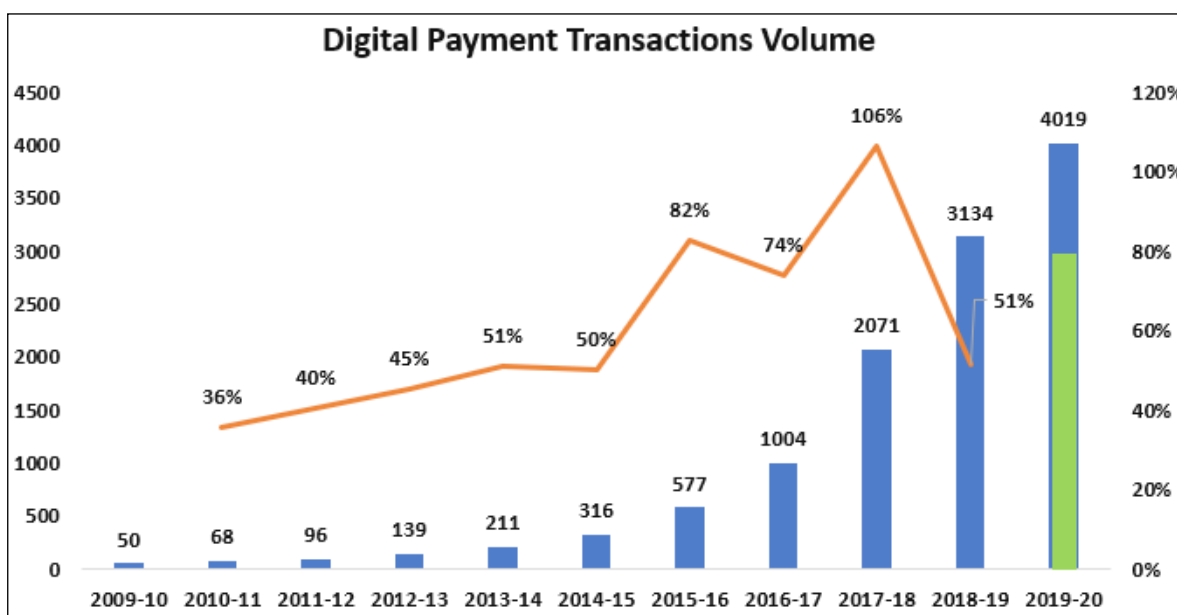

Growth of Digital Payments (in Cr)

Source: RBI, NPCI and Banks

Note – Final data for September 2019 is yet to be published by RBI

In 2016-17, country has seen 1004 (1003.67) cr digital transaction which reflected an increase of 74% YoY. In 2017-18, 2071 cr digital transaction has been recorded with an increase of 106% growth YoY, against the total target of 2500 cr. In FY 18-19, mission has targeted to increase the digital transactions to 3013 crore and till 31st March 2019, 3134 crore digital transactions have been recorded which reflect an increase of 51% YoY. In FY 19-20, mission has allocated a target of 4019 crore digital transactions where 2923 crore has been achieved till December 2019 (Final data is yet to be published by RBI). This increase can be attributed to development of innovative digital payment platforms such as Bharat Interface for Money (BHIM)-UPI, BHIM Aadhaar and BharatQR code. In Dec 2016, NPCI launched BHIM app (based on BHIM-UPI platform), which has been downloaded by more than 6 Cr users. Several Payment Service Providers (PSPs) have launched BHIM-UPI based apps such as Google (GPay), PhonePe and Paytm. This has made BHIM-UPI crossed a milestone of

258 Lakh transactions per day and emerged as the most used digital payment platform after cards and wallets. Since demonetization, five modes of payments namely BHIM-UPI, Immediate Mobile Payments System (IMPS), Aadhaar enabled Payments System (AePS), mWallets and Debit Cards) have significantly contributed to the growth of digital transactions.

Growth of Digital Payment Acceptance Infrastructure

The associated institutions — Banks and NPCI have also upped the ante on the payment acceptance infrastructure front, wherein the digital Payment acceptance infrastructure has increased from 15.12 lakh PoS machines in Oct 2016 to 33.32 lakh PoS machines in Aug 2018 (as per RBI published report). Till September 2018, 152 lakh merchants PoS devices are present in the market including Bank’s wallets, BHIM (UPI), Bharat QR Code, BHIM app, Bank’s own QR Code, BHIM Aadhaar Pay, USSD (*99#) (as per DFS). Similarly, there

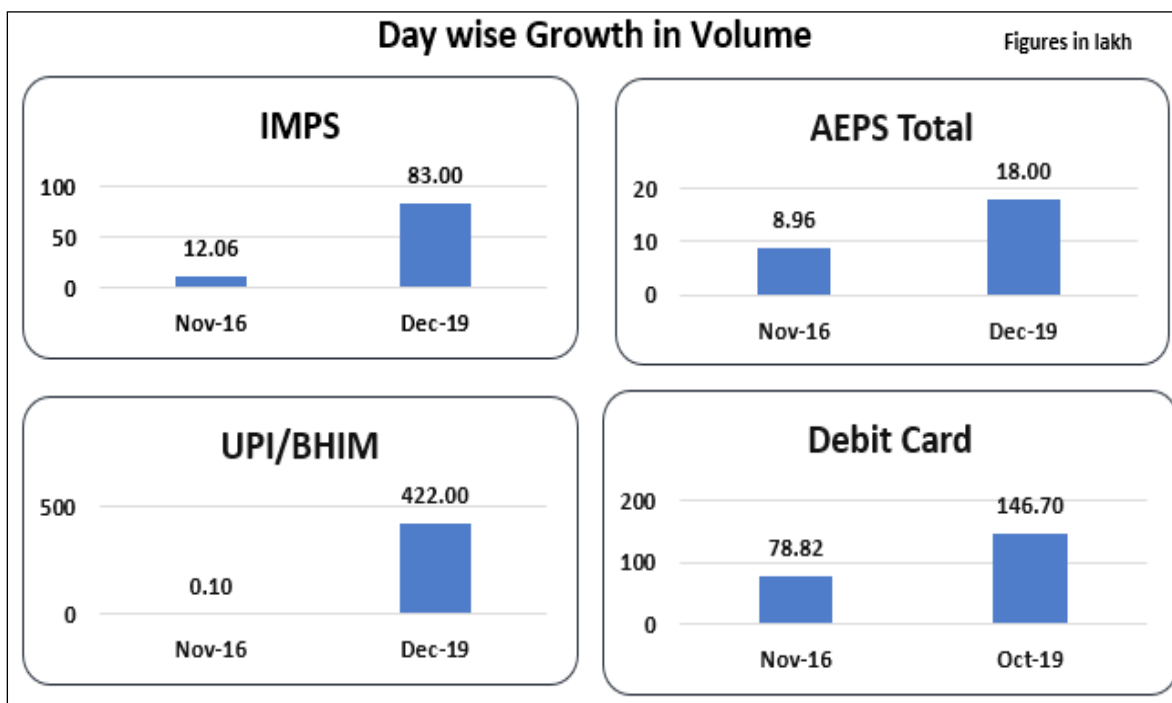

Growth in the Volume of Digital Payment Transactions modes since Demonetization (Source: NPCI and RBI)

Note – Final data of Debit Card for September month is yet to be published by RBI

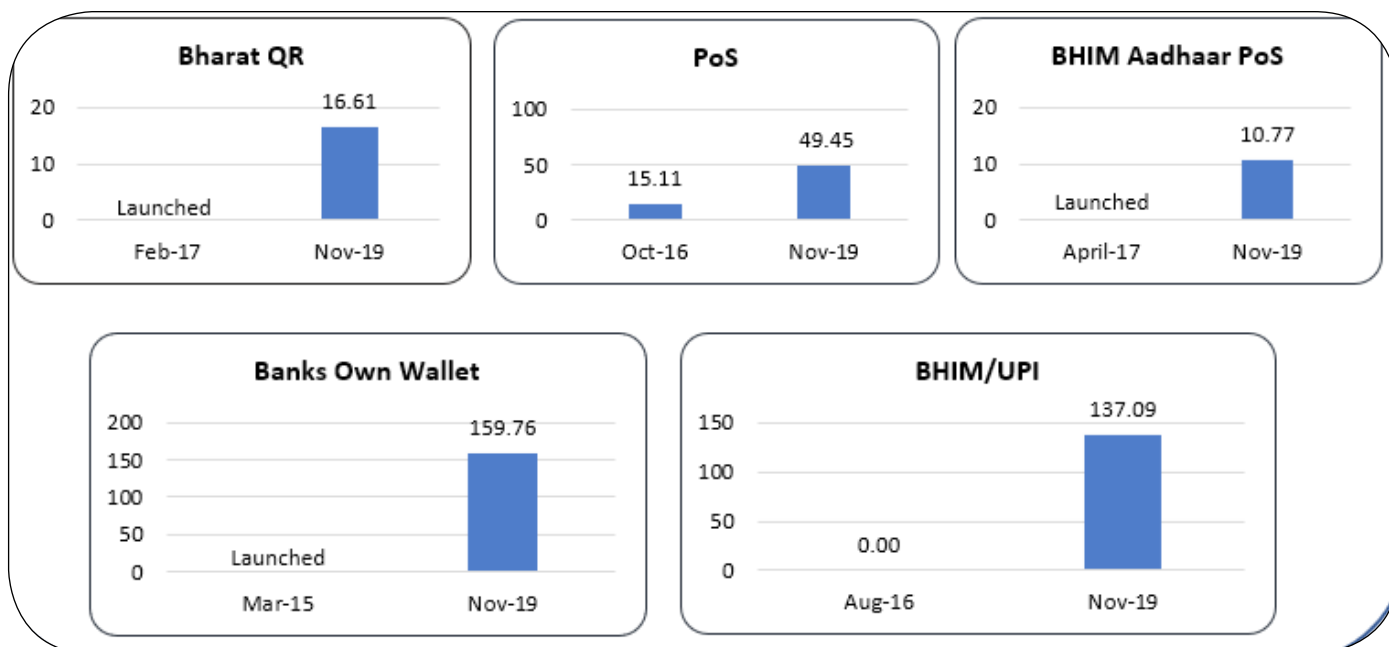

Growth of Digital Payments Acceptance Infrastructure (in lakh)

Note – Data is available till November, 2019

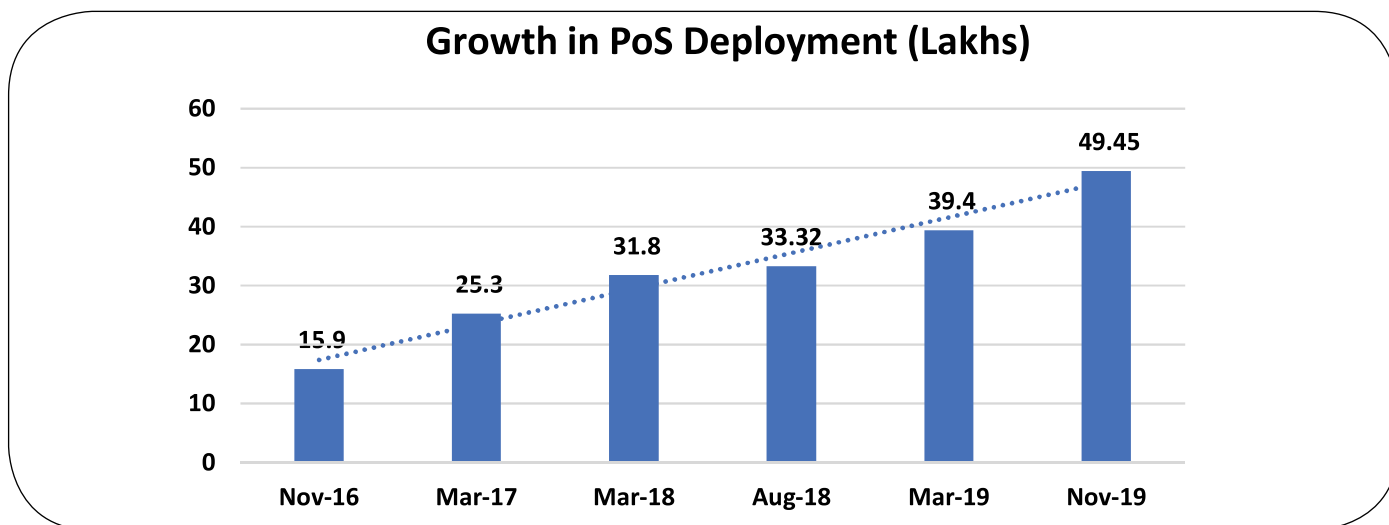

Growth of Digital Payments Acceptance Infrastructure As per DFS report

has been growth in number of Pre-Paid Instruments (PPIs) in the market and regulatory regime is moving towards greater interoperability of PPIs.

Universalization of Digital Payment Infrastructure

In order to enable every citizen in the country who may belong to any economic strata, suitable

technologies are adopted. People with smart phones applications have a host of options to make payments through apps that run on BHIM-UPI platform. People having feature phones can opt to make transactions using USSD. People who do not have any phone can use Aadhaar enabled Payment System (AePS) and BHIM Aadhaar Pay for banking transactions.

Incentivization of Digital Payments & Dis-incentivize Cash transactions

- Notification on Subsidizing MDR Charges on Debit Cards/BHIM UPI/AePS transactions of value less than or equal to 2000/- has been issued on 27th December 2017.
- The duration of the Scheme for two years from 01-01-2018 to 31-12-2019.
- All the Acquiring Banks are eligible for the Scheme.
- Banks are submitting Quarterly claims to RBI and RBI is releasing payments to the respective banks.

Preferred Approach

On digital payment acceptance infrastructure side, Government of India has strategized to saturate the acceptance points with BHIM QR code, in addition to any other modes. In respect of payments that are repetitive in nature such as utility payments, the strategy is to onboard all the utilities on the Bharat Bill Payment System (BBPS). This will enable to have the option of accepting payments from any consumer through any mode from any bank. Ultimately any entity receiving payments should be able to offer following options to the citizens:

- Printing of BHIM QR code (preferably dynamic) on bills

- Enabling following options in all shops/physical payment receipt counters:
 - Pull request through Mobile no. /Virtual Payment address (VPA) wherein a request of bill amount is received on BHIM/UPI enabled App of the customer,
 - Prominent display of printed static BHIM QR code at the billing counter to enable customer to scan and pay,

Considering benefits of digital payments, any payment acceptance entity may consider offering a visible discount on digital payment vis-a-vis cash.

New Products and Services

• BHIM 2.0

About BHIM: In order to encourage the digital payments and unleash the power of mobile phones for digital payments, BHIM app was launched by Hon'ble PM on 30th December, 2016. BHIM app is a UPI (Unified Payments Interface) based payment interface developed by NPCI (National Payments Corporation of India) which allows real time fund transfer using a single identity like your mobile number or name. BHIM App is bank agnostic app for online person to person funds transfer and is available on Android and iOS platforms.

In order to make BHIM app more effective the following new features alongwith enhancement in



Launch of BHIM 2.0 by Hon'ble Minister (Electronics & Information Technology)

existing features have been incorporated under BHIM 2.0 which was launched by Hon'ble MEIT on 21st Oct, 2019:

New features

- Introduction of "Donation": Now any BHIM user will be able to donate directly to organizations that are working towards humanitarian cause including PMNRF and various CM relief funds.
- Merchant offers: BHIM users will be able to view offers from leading merchant on BHIM UPI
- Introduction of new languages: Currently BHIM users can access the app in 13 languages and in order to make it easier for others to use, the next version will introduce new languages.

Enhancements

- Increased limits for merchant (P2M) transactions: Currently the upper limit for a transaction in BHIM is Rs. 20000/-. This limit will now be increased.
- Linking of multiple bank accounts: Currently a BHIM user can only do transaction with a single linked account. Now, the customer shall be able to link more than one bank account and use any account at the time of the transactions without changing the default bank account.
- Send to self: Customer shall now be able to transfer funds between own linked bank accounts.

National Common Mobility Card (NCMC)

National Common Mobility Card (NCMC) has been launched by the Government, to provide an easy, convenient and fast method of digital payment to the citizens for all routine low value transactions including public transport and retail. This will enable a single interoperable digital payment mode in all the Metros, Railways and Bus services along with

retail to fulfill the vision of 'One Nation One Card'. NCMC supports both online and offline transactions through dual interface (contact and contactless). Passengers no longer have to stand in multiple queues for purchasing tickets. The card will meet the ticket expenses based on stored value of money and the user will be able to top up the stored value through various modes of payment like Internet Banking, IVR, Cash at customer service point etc. at the option of the issuing authority or bank. Going ahead, the card will support more and more applications for increased convenience which will allow the citizens to use the same card for variety of needs and also free them for carrying separate cards for banking and transit requirements.

Digidhan Mitra Chatbot

'Digidhan Mitra' has been developed which is an Artificial Intelligence (AI) based chatbot which provides on-demand data and information from Digidhan Dashboard portal, which tracks digital payments made through various modes. The dashboard acts as a central platform for accurate reporting, monitoring and analysis of all digital payments' transactions occurring in the country and enablement of infrastructure through deployment of Physical/Mobile/BHIM Aadhaar PoS devices. Salient features of chatbot are as given:

- Functions 24 × 7 with due diligence
- Capable of handling queries in English and Hindi
- Text and Voice based interactions
- Powered by AI with a conversational UI
- Provides data in tabular as well as graphical form

MeitY Campaigns

Promotion of Digital Payments in North East State Capitals: MeitY organized promotional workshops on Digital Payments in all the capitals of the North East States.

Ministries & Departments Progress

For FY 2019-20, a target of 3971 crore Digital payment transactions have been allocated to Ministries/ Departments.

Promotion and Publicity of Digital Payment Transactions

In order to create awareness of this programme amongst citizens of India and proliferate the intended benefits of digital transaction, a 360-degree communication and awareness campaign was undertaken through various channels, including Print, Television, Radio, Digital and on-ground activities.

- **Digital Payments promotion template for Banks:** MeitY has created a template for Banks on promotion of digital payments. The promotional plan from 27 Banks has been received and those plans have been assessed.
- **Digital Payments page on MeitY website:** The page containing matter related to the Digital Payments is being regularly updated on the details of incentives and promotion schemes to make the citizen well-informed.
- **Launch for incentive/promotion schemes:** MeitY has launched several incentive/promotion schemes such as,
- **Meeting with Ministries & Departments:** MeitY Digital Promotion team has conducted a number of meetings and workshops with various Ministries & Departments across Central and State level for promotion and creating awareness for digital payments.
- **Digital Jagriti** - Common Service Centers are conducting Digital Financial Inclusion Awareness and Access (Digital Jagriti) programmes for citizens on usage of digital payments modes and supporting merchant on-boarding for acceptance of digital payments.

- **DigiShala-** Free Doordarshan DTH educational channel available in Hindi, English and regional languages for creating awareness regarding various forms of electronic payment. DigiShala is available through GSAT15 (DD Direct DTH), 93.5-degree East, Receive frequency: 11,590 MH.

Ministries/Department and States/UTs related

For FY 2019-20, a target of 3,971 crore Digital payment transactions have been allocated to Ministries/ Departments.

MeitY has been actively engaged in promotion of Bharat Bill Payment System (BBPS) and pursuing all the Utility Billers (Power/Gas/Water/Telecom/DTH) throughout the country for onboarding on the BBPS ecosystem. Bharat Bill Payment System is a unified ecosystem, which aggregates multiple billers onto a single platform. BBPS provides an interoperable and easily accessible bill payment service to consumers via multiple channels like Internet Banking, Mobile Banking, Mobile App, etc. On-boarding of all utilities on the BBPS ecosystem would be a major enabler of Digital Payments by providing an easy interface to citizens for digital payment of bills. As a result of efforts made by MeitY and NPCI, the number of BBPS on-boarded billers has significantly increased from 51 in Oct-2017 to 140 in October 2019

	Oct-2017	Oct-18	Oct-19
Live Billers	51	107	140
Transactions Volume (Mn)	0.76	6.95	12.60
Transaction Value (In Cr)	₹ 67.39	₹ 910.49	₹ 2,251.81

Note: Volume and value of transactions represented are passing through BBPCU (Bharat Bill Payment Central Unit)

- MeitY has been making efforts for promotion of BHIM, BHIM QR, NCMC, BHIM Aadhaar and Rupay Card. All Ministries and States

have been communicated for promotion of these modes of Digital Payments. Further, all Payment Service Providers/aggregators has been communicated to ensure adoption of BHIM and Rupay Cards.

- Till date more than 100 grievances, pertaining to Digital Payments, received on the Centralized Public Grievance Redress and Monitoring System (CPGRAMS) portal and from PMO, O/o MEIT were attended and resolved. Cases relating to cyber digital frauds were also analyzed and resolved with the support of Police Departments. Due to MeitY's efforts many disputes of wrong online transactions were resolved, and the petitioners received their money back.
- To promote and create awareness about benefits of digital payments and incentives schemes being offered by MeitY and other Ministries/Departments, through social media platform and websites, various creatives were prepared in collaboration with NPCI and the same were uploaded on MeitY's social media handle/page (twitter and Facebook).

MDR Reimbursement Scheme

To promote digital payment transactions in the country, MeitY was implementing the following Merchant Discount Rate (MDR) Reimbursement Schemes, wherein MDR claims of the acquiring banks were being reimbursed by the Government:

- MDR Reimbursement Scheme on transactions of value upto Rs.2000 done through Debit cards/ BHIM Unified Payments Interface (UPI)/ Aadhaar Pay
- MDR Reimbursement Scheme on Government receipts upto Rs.1 lakh for transactions made through Debit cards

MDR Reimbursement Schemes have ended on 31st December, 2019.

Strengthening Grievance redressal mechanism

MeitY has integrated Digital Payment Grievances along with Ministry of Consumer Affairs (MoCA) for utilizing it with National Consumer Helpline (NCH) platform of Department of Consumer Affairs (DoCA) in addition to the existing Grievance Redressal Mechanism of digital payments with the respective banks. Almost 56 banks and other financial service institutions have been on boarded into NCH Platform. NPCI has also been integrated as a convergence partner in National Consumer Helpline (NCH) platform. The NCH platform is live and receiving Digital Payment related grievances.

Promotion and Publicity of Digital Payment Transactions

The Demonetization gave Government of India an opportunity to take up Digital Payments initiative aggressively.

The Indian Fintech market is forecast to touch USD 2.4 billion by 2020* from a current USD 1.2 billion. The transaction value for the Indian fintech sector was estimated to be approximately USD 33 billion in 2016 and is forecast to reach USD 73** billion in 2020 growing at a five-year CAGR of 22%. As per EY's recently released Fintech adoption Index India ranks second with 52% adoption rate only behind China at 69%.

Payment systems like UPI / IMPS are likely to register average annualized growth of over 100*** %. FinTech's are actively working towards expanding the acceptance infrastructure through acquisition of low revenue merchants on digital acceptance platform.

Awards: MeitY has invited proposals from fintechs and banks working in digital payment infrastructure space especially in rural sector, using emerging technologies in digital payment space, creating financial inclusion through innovating products in digital lending sector. After a thorough evaluation which included proposal submission followed by in

* Source: NASSCOM

** Source: India fintech landscape report by IFOR and Yes Bank

*** Source: RBI Payment vision document 2019-21

person presentation, below are the top performing financial institutions in different sectors.

Fintechs:

Financial Technology (Fintech's) Institutions have seen a tremendous growth over the last few years, contributing significant amount of advancement and innovation in Digital Payments across India.

Indian Fintech's have earmarked upon its digital journey and is catching up fast with its global peers in terms of adoption. Below is the list of Fintechs receiving awards for their outstanding performance in different categories –

Sr. No.	Fintech Company	Category
1	PayNearby	For Innovation in Digital Payment Acceptance Infrastructure in Rural India For their outstanding performance in improving Digital Payment Acceptance Infrastructure in Rural India
2	PhiCommerce	
3	ToneTag	For Innovation in Digital Payments through Emerging Technology
4	BharatPe	
5	ePayLater	
6	Aye Finance	
		For excellent performance in Digital Payments in Lending sector

Banks:

Banks has been the key player in driving this whole digital economy and below is the list of Titles/Awardees being given to Banks for their outstanding achievements in different categories.

S. No.	Bank	Title
1	Paytm Payments Bank	For Outstanding Performance in Digital Payment Transactions under Category of above 100 Cr Target

S. No.	Bank	Title
2	Punjab National Bank	For Outstanding Performance in Digital Payment Transactions under Category of 50-100 Cr Target
3	Airtel Payments Bank	For Outstanding Performance in Digital Payment Transactions under Category of 10-50 Cr Target
4	Indian Bank	
5	Fino Payments Bank	For Outstanding Performance in Digital Payment Transactions under Category of less than 10 Cr Target
6	State Bank of India	For Outstanding Performance in POS Deployment in Rural India in Public Bank Category
7	ICICI Bank	For Outstanding Performance in POS Deployment in Rural India in Private Bank Category
8	Indian Overseas Bank	For Outstanding Performance in POS Deployment in Northeast in Public Bank Category
9	RBL Bank	For Outstanding Performance in POS Deployment in Northeast in Private Bank Category
10	State Bank of India	For Outstanding Performance in BHIM Aadhaar POS Deployment in Public Bank Category
11	ICICI	For Outstanding Performance in BHIM Aadhaar POS Deployment in Private Bank Category
12	SBI Bank	For Outstanding Performance in Merchant Onboarding on BHIM and Bharat QR in Public Bank Category
13	HDFC Bank	For Outstanding Performance in Merchant Onboarding on BHIM and Bharat QR in Private Bank Category
14	Yes Bank	For Overall Performance in Digital Payments
15	IndusInd Bank	

Glimpses of the Day: Below mentioned are few glimpses of Award Ceremony in the presence of Hon'ble Minister of Electronics and IT, Sh. Ravi Shankar Prasad and other MeitY associates.

Launches:

- o **Launch of DigiDhan Dashboard**

DigiDhan Dashboard, a dashboard platform to monitor the growth of various digital payments transactions, is launched by Shri Ravi Shankar Prasad, Hon'ble Minister of Electronics & Information Technology and Law & Justice in

presence of eight State IT Ministers and more than 30 State Secretaries during National Conference of State IT Ministers and IT Secretaries in Vigyaan Bhawan on 13th February 2018.

- o **Launch of DigiDhan Mitra Chatbot**

The Digidhan Mitra AI Chatbot was launched by Shri Ravi Shankar Prasad, Hon'ble Union Minister, Ministry of Electronics & Information Technology and Law & Justice during the National meet on grassroot Informatics, VIVID on 21st Feb 2019. The meet was held as an initiative to interact with the



Shri Ravi Shankar Prasad, Hon'ble Minister, Electronics & Information Technology and Law & Justice, launching DigiDhan Dashboard



Shri Ravi Shankar Prasad, Hon'ble Minister, Electronics & Information Technology and Law & Justice, launching DigiDhan Mitra Chatbot

DIOs and to share their experiences & contributions, as digital change-makers at the grass root level in the States. It was attended by many Senior Government officials from NIC and Central & State Governments.

- o **The Awards conferred to Digidhan Dashboard for the year 2019-20 are compiled as follows:**

Award #1

Award Type	'Adoption of Digital Payments – Central Govt.
Award Provider Name	Digital Transformation Summit & Award 2019
Winner Team Name	Digidhan Dashboard
Awarded Date	6 th November 2019
Location	New Delhi



Shri IPS Sethi, DDG, NIC receiving the Award for Digidhan Dashboard under the "Adoption of Digital payments -Central" category. S N Tripathi, Director, IIPA and Shri Vinit Goenka, Member Governing Council of CRIS, seen in picture.

o **Award #2**

Award Type	Gems of Digital India in the 'Analyst's Choice' category
Award Provider Name	Gems of Digital India Awards 2019
Winner Team Name	Digidhan Dashboard
Awarded Date	13th Sept September 2019
Location	New Delhi



o **Award #3**

Award Type	Technology Sabha Award
Award Provider Name	Indian Express Group
Winner Team Name	Digidhan Dashboard
Awarded Date	9-11th August 2019
Location	Vizag

2.4.2 e-Learning

E-Learning is an effective tool for quality and lifelong education to learners. E-Learning is the learning facilitated and supported by Information Communication Technologies (ICT). Advancements in ICT have made possible the availability of quality education on 24x7 basis to millions of people in a cost-effective manner. The use of ICT in education has opened the doors for “anytime, anywhere” learning. Supplementing the formal way of education with e-learning tools/content and use of ICT in formal education is important to facilitate enhanced learning environment; especially when there is large gap in demand and supply of quality content and educators. The Ministry has been financially supporting R&D projects in this area at various academic educational institutes, R&D Labs etc. for development of tools and technologies to promote e-learning.

The project “Rollout of Online Labs (OLabs) for schools” being implemented by CDAC, Mumbai jointly with Amrita Vishwa Vidyapeetham, Kollam, Kerala, aims to create infrastructural and support framework for making OLabs (online labs for schools) accessible and usable by students and teachers across India and to train approximately 30,000 teachers across India in effective use of OLabs resources to enhance the teaching learning experience. Total duration of the project is 3 years with budget outlay of ₹ 816.00 lakh. The project was further extended for one year. Online Labs (Olabs) is available for public access at www.olabs.edu.in. For Olabs Offline, Olabs Live bootable DVD and Olabs Windows Installer is available and is updated periodically with the website dump. Helpdesk is hosted at <http://support.olabs.co.in/>. Various queries regarding Olabs training, login and feedback on lab contents are being received. Gmail account is also setup for receiving queries through emails. Different queries about the OLabs website from educators, teachers, researchers and educational

institutions are received on gmail. Support number is also available. With regard to training of CBSE teachers, so far 24,646 CBSE teachers have been trained from 7,645 CBSE schools.

2.4.2.1 Language Computing :

Natural Language Translation Mission

MeitY is in the process of initiating Natural Language Translation Mission (NLTM) on the recommendations of Prime Minister’s Science, Technology and Innovation Advisory Council (PM-STIAC). NLTM aims at removing language barrier among all major Indian languages, particularly in the domains of science and engineering, education, healthcare, governance, law & justice, etc. Under the mission, it is envisaged to build machine translation systems which could be used to translate from one Indian language to another with minimal human involvement. It is also planned to create and nurture an ecosystem involving start-ups to develop and deploy innovative solutions in Indian languages. Further, language-specific Missions for each of the constitutionally recognized languages are to be initiated in partnership with the State Governments with an objective to increase the content in Indian languages on the Internet manifold. In this regard, a detailed project report has been prepared in consultation with the stakeholders and necessary action is being taken for approval.

National Platform for Language Technology

National Platform for language Technology (NPLT) has been developed to provide an e-marketplace for the stakeholders in language technology. The platform is open to public as well as private players. At present, it hosts a good number of linguistic resources developed under various projects sponsored by MeitY. The resources include parallel text corpora for major Indian languages for use in machine translation, speech corpora in several Indian language for automatic speech recognition

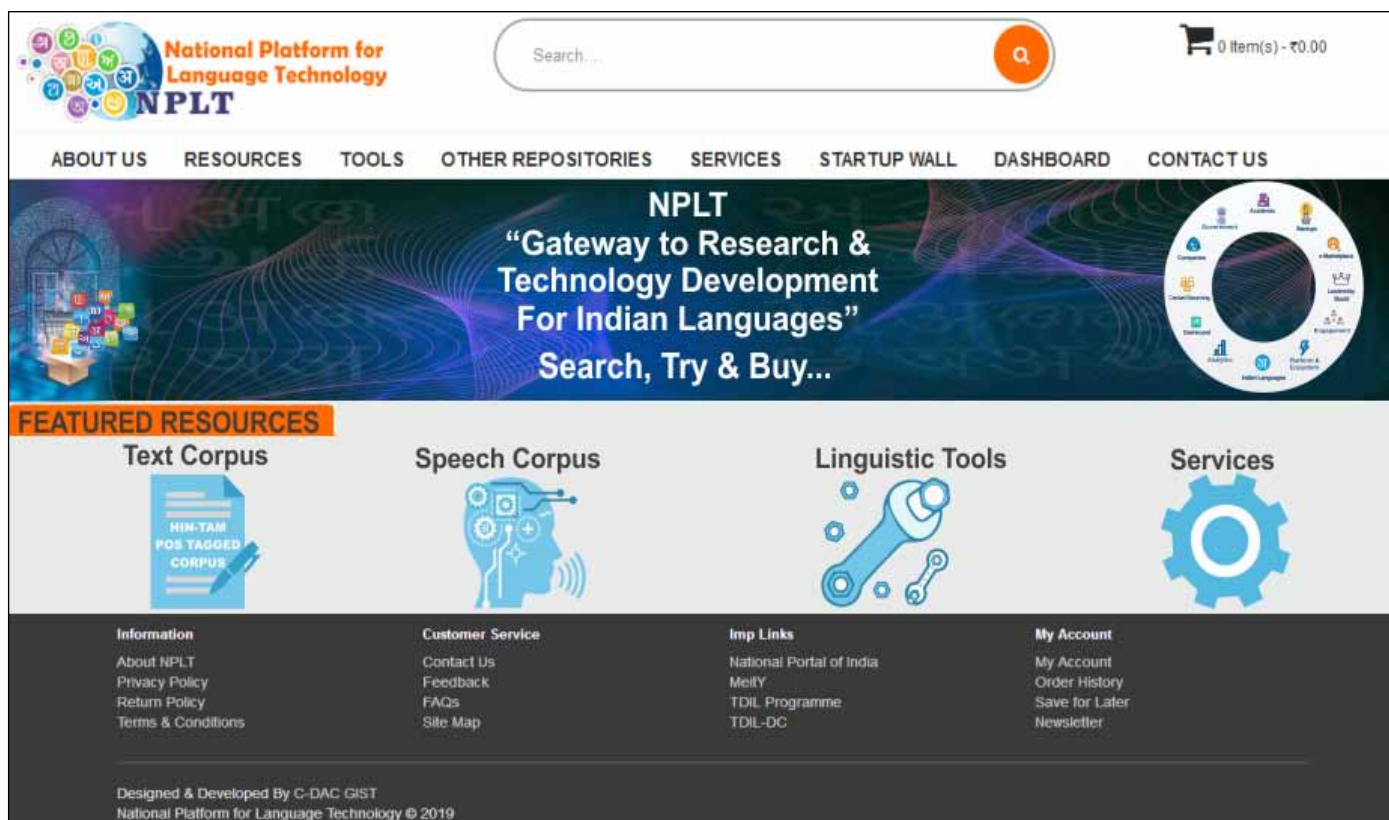

and speech synthesis. It also hosts several other language tools such as WebOCR, IndoWordNet, HindiWordNet, glossary tool, etc. NPLT would also have a leadership board for language technology products and services. The platform has been developed by C-DAC under a project sponsored by MeitY.

So far, these linguistic resources/tools were being given to Indian academic researchers only. It has now been decided to make it available to start-ups, IT companies and international academic researchers as well. This would be given free of cost to Indian start-ups and academic researchers whereas other companies would have to pay the price of the resource. There is an option to download a demo/trial version of any resource/tool to try out its features before buying it. The platform also provides a place to showcase tools and systems in language technology. One can also provide language technology-based services through the platform. For instance, one can host a machine translation system on the platform for users who can use it on payment basis.

HEMAT

Bidirectional Hindi to English Machine Aided Translation System (HEMAT) for Judicial domain has been developed by a consortium of six institutions

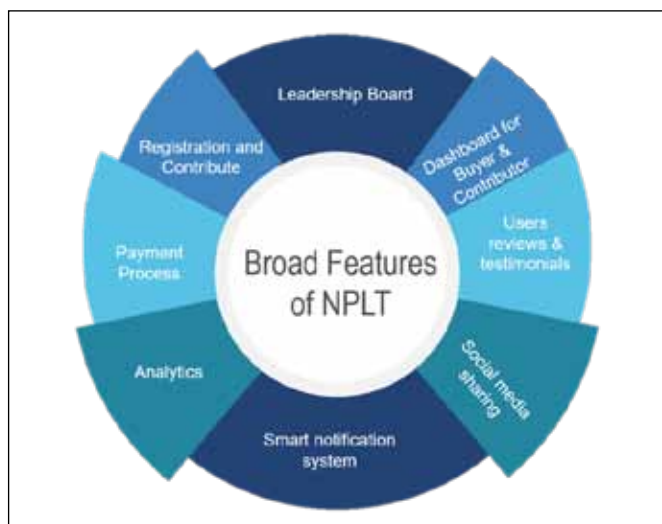

led by IIT Patna. About three lakhs parallel Hindi-English sentences from judicial domain have been collected as bilingual corpus. Beta version of HEMAT translator is available at <http://www.iitp.ac.in/~kamal.pcs17/>. The system has also been hosted at some of the courts under 'Supreme Court Vidhik Anuvaad Software' (SUVAS).

Screen Reader for Indian Languages:

In one of the MeitY sponsored project, Text-to-Speech System for 13 Indian Languages namely Hindi, Bengali, Marathi, Tamil, Telugu, Malayalam, Gujarati, Odia, Assamese, Manipuri, Kannada, Bodo and Rajasthani were developed using Open Source engines by a consortium led by IIT Madras. Now an API has been developed which can be used by any website developer to make the website screen readable. Using the facility, the content being displayed on the screen is read out in the language of choice. This helps the users who have any type of reading difficulty. The API is available at URL: <http://tdil-dc.in/ttsapi/demo/readme.html> for integration with any website and it has already been integrated into the Hindi portal links of the websites: www.mdoner.gov.in, www.cca.gov.in, www.dpe.gov.in, www.epramaan.gov.in, www.delhitourism.gov.in, www.mohua.gov.in, www.localization.gov.in.

2.4.3 Initiatives on Accessibility

- A National Policy on Universal Electronic Accessibility was formulated by Ministry of Electronics and Information Technology (MeitY) and it was notified on October 25, 2013. The policy facilitates equal and unhindered access of Electronics and ICTs products and services by differently-abled persons.
- As part of Accessible India Campaign, a flagship programme of Department of Empowerment of Persons with Disabilities (DEPwD), MeitY is making continuous efforts to make websites of respective Ministries/ State Governments accessible and following up with Central Ministries and States for the same.

2.5 Digital India Publications

India's digital story is one of an ICT - led development by use of technology that is affordable, inclusive and transformative. The Digital India Programme aims to transform India into a knowledge-based economy and a digitally empowered society.

2.5.1 Release of the Yojana on "Citizen Centric e-Services"

Yojana is a monthly journal, published by Publication Division of Ministry of Information & Broadcasting.



Release of Yojana Magazine on "Citizen Centric e-Services"

Yojana journal is devoted to the socio-economic issues. It started its publication in 1957 with Mr. Khuswant Singh as the Chief Editor. The magazine is now published in 13 languages viz. English, Hindi, Urdu, Punjabi, Marathi, Gujarati, Bengali, Assamese, Telugu, Tamil, Kannada, Malayalam and Odia.

The July 2019, issue of Yojana was launched by Sh. Ravi Shankar Prasad, Hon'ble Minister for Electronics & Information Technology on 1st July 2017. This issue was a special issue & the theme was "Citizen Centric e-Services". The articles were written by eminent authors from Industry & officers of MeitY, on Digital Empowerment , Digital Infrastructure, e-education, e-health & other e-Services.

2.6 Celebration of 150th birth anniversary of Mahatma Gandhi

MeitY celebrated the 150th birth anniversary of Mahatma Gandhi with great enthusiasm, fervor and spirit on 03.10.2019. Paying homage to the Mahatma, Shri Prasad unveiled the "Digital Charkha", a grand art installation at MeitY. Glittering

in its tri-colour splendour, the "Digital Charkha" is an amalgamation of the traditional design with a digital spin. The wheel of the Charkha is made up of interlinked digital grids in place of fine threads thus portraying that the core of Digital India is embedded in Gandhian philosophy of equality, unity, corruption free and empowerment of ordinary citizens. This philosophy resonates with the Prime Minister's vision for a *NEW DIGITAL INDIA* that promises to deliver e-Governance services as basic fundamental rights to each and every citizen of the country. Speaking on this special occasion, Shri Ravi Shankar Prasad, Hon'ble Minister for MeitY said "We are committed to move towards a Plastic Free workplace. The Government machinery is in full swing to cut down Single Use Plastic by 2020".

Shri Prasad also launched a film showcasing the activities executed by the Ministry which are aligned with Gandhi ji's philosophy of cleanliness, inclusion of the marginalized population in the country, hard work and dedication to lead the country towards Good Governance. Keeping with Gandhi ji's philosophy for a clean environment, the Minister and senior MeitY officials took to brooms and



Art Installation of Digital Charkha at MeitY

cleaned the office building with great gusto. Shri Ravi Shankar Prasad administered a Swachhta Pledge to all officers and staff members. Planting saplings on the lush green lawns at MeitY premises, Shri Prasad reminisced about the Mahatma's desire for a clean and green Swachh Bharat. Mahatma Gandhi had said that Cleanliness is next to Godliness. And MeitY's contribution towards an inclusive, progressive and an empowered Swachh Bharat is the real tribute to Bapu on his 150th Birth Anniversary.



Hon'ble Minister (&IT) and Secretary (E&IT) with Staff Members during Cleanliness Drive at MeitY

Besides the above, Shri Prasad told that the aim of the Govt. is to make all Offices SUP free. Hence, in pursuance to the Orders of the Govt., MeitY banned all forms of disposable plastics including grocery bags, straws, cutlery, cups, plates, cotton buds, water bottles and other SUP items.

In MeitY, **Swachhta Hi Seva (SHS) 2019** was observed with great fervor, spirit and active participation of the officers and staff of the Ministry of Electronics and Information Technology (MeitY) from 23rd September to 2nd October, 2019. A day-wise Action Plan was prepared for implementation by MeitY/Its Offices. One of the major points of the Action Plan of MeitY was "Plastic Waste Management (PWM) and Effective Ban of Single Use Plastic(SUP)" involving the community at large. As a part of this initiative, a lecture reg. "Plastic Waste Management and Ban of Single Use Plastic" was organized on 25.09.2019 in the Conference Room of E.N. Building for Housekeeping, Canteen staff and officials of MeitY, to inculcate good practices/habits. General cleaning activities were also widely intensified by Meity/Its Organisations, vis-à-vis, laying emphasis on weeding out of old/



Ganga Cleaning Exercise



Gandhi Cycle Rally for Peace

unused files/registers and disposal of unused items/equipments.

MeitY has taken a number of steps to cut plastic consumption, including permitting canteen to use paper-sealed glass bottles for captive use instead of packaged drinking water. Messages/Slogans focused on “Plastic Waste Management and towards the effective ban of Single Use Plastic” and its safe/proper disposal were widely publicized/ displayed, physically and electronically and through the website of Meity/Its Offices. **SHS 2019** activities on “Plastic Waste Management & Ban of Single Use Plastic” and “Shramdan” were widely publicized through electronic and social media like MyGov, Twitter, Facebook etc. and also uploaded the same on the website of the M/o DWS. Photographs of some events carried out to commemorate the “150th Birth Anniversary of Mahatma Gandhi” are depicted :

2.7 100 days Programme of Ministry of Electronics & Information Technology (MeitY):

In 100 days programme of the Government following two transformative ideas were selected from MeitY:

MeitY Start-up Hub (MSH): MSH, launched on 21st October, 2019 by Hon’ble Minister for Electronics & IT, will act as a national coordination, facilitation and monitoring centre that will integrate all the incubation centres and start-up and innovation

related activities of MeitY. It) will act as a hub for facilitating criss-crossing of technology resources, sharing best practices, ideas and monitoring across the entire innovation and start-up ecosystem. As on date, 1200+ startups, 150+ incubation centres and 140+ mentors have been registered onto the portal.

BHIM 2.0 : BHIM 2.0 (Bharat Interface for Money), launched on 21st October, 2019 by Hon’ble Minister for Electronics & IT, is built on the unified Payments Interface (UPI) 2.0 to enrich the user experience with its simple and intuitive user interface with additional features such as donations, IPO investments etc. India’s experience of **BHIM** (Bharat Interface for Money) /**UPI** (Unified Payments Interface) has transformed the digital payment ecosystem.

2.8 Sectoral Group of Secretaries(SGoS) – Technology

With a vision of Technology Empowered “New India” a Sectoral Group of Secretaries (SGoS)-Technology has been constituted which consists of 11 technological departments/ministries of India. Under this, MeitY envisions to create a Strong, Secure and Sustainable Digital Economy by harnessing digital technology & fostering innovation. MeitY’s thrust would be on creating more nationwide Public Digital Sectoral Platforms, creating next generation infrastructure, strengthening Manufacturing with Expand & Export strategy and developing India as a software product nation.



Chapter – 3**Make in India: Electronics Manufacturing**

The demand of Electronics is expected to rise rapidly to about USD 400 Billion by the year 2025. The Government attaches high priority to electronics hardware manufacturing. It has the potential to generate domestic wealth and employment, apart from enabling cyber-secure ecosystem. The electronics manufacturing sector requires continuous push with the overall objective of promoting ‘Make in India’, not only to meet the domestic demand but also to promote India as a global hub for electronics manufacturing. Several policy initiatives under the “Digital India” and “Make in India” programmes are designed to facilitate investment, foster innovation, protect intellectual property and build best-in-class manufacturing infrastructure towards creating conducive environment for attracting investment in the electronics hardware manufacturing sector. The intent of the Government is to provide a level playing field for domestic manufacturers to enable

them to compete with imports in the sector, by rationalization of tariff structure, simplification of procedures, enabling policies, providing incentives and upgrading infrastructure. As a result of various measures taken over the last few years, production of electronics hardware has shown significant increase. The demand of electronics hardware is increasingly being met by domestic production. The following initiatives have been taken in this regard:

3.1. Modified Special Incentive Package Scheme (M-SIPS)

In order to promote large scale manufacturing in the country, M-SIPS was announced by the Government in July, 2012 to offset disability and attract investments in Electronics System Design and Manufacturing (ESDM) Industries. The scheme provides incentive for investments on capital expenditure- 20% for investments in Special Economic Zones (SEZs) and 25% in non-SEZs.

The incentives are provided on reimbursement basis. The policy provides for an inter-ministerial Appraisal Committee to evaluate investment applications. Based on the recommendation of Appraisal Committee, approval of Competent Authority is obtained.

The Union Cabinet in its meeting held on 21st July 2015 has approved the extension of M-SIPS and also approved amendment of M-SIPS in order to simplify the procedure and enhancement of scope and the notification of amendment in M-SIPS (simplifying procedure, enhancement of scope and extension for 5 years) was issued on 03.08.2015. Further, the Union Cabinet in its meeting held on 18.01.2017, approved certain amendments in the M-SIPS policy which were notified on 30.01.2017. These amendments are expected to expedite investments in electronics manufacturing. As per the directions of the Cabinet, a separate committee headed by Cabinet Secretary has been set up for mega projects, envisaging more than Rs. 6,850 crore investments (investment above 1 billion USD). The Scheme has been closed on 31st December, 2018 to receive new applications and is in implementation mode.

The status of M-SIPS applications as on 30th November, 2019 is as follows:

407 applications with proposed investment of Rs. 1,09,768 crore are under consideration. Out of these, 235 applications with proposed investment of approximately Rs. 66,407 crore have been approved, 31 applications with proposed investment of approximately Rs. 13,072 crore have been recommended by the Appraisal Committee for approval and 141 applications with proposed investment of Rs. 30,289 crore are under appraisal process.

The incentives to the tune of Rs. 836.19 crore have been disbursed to the 64 applicants. Out of 407 applicants, 181 applicants have started incurring investment on their projects and made investment of Rs. 17,238 crore. 163 applicants have commenced commercial production with reported turnover of Rs. 1,61,737 crore, which includes exports to the tune of Rs. 29,326 crore. These units have given employment opportunities (Direct & Indirect) to 1,17,685 persons and given revenue of Rs. 21,993 crore to the Government.

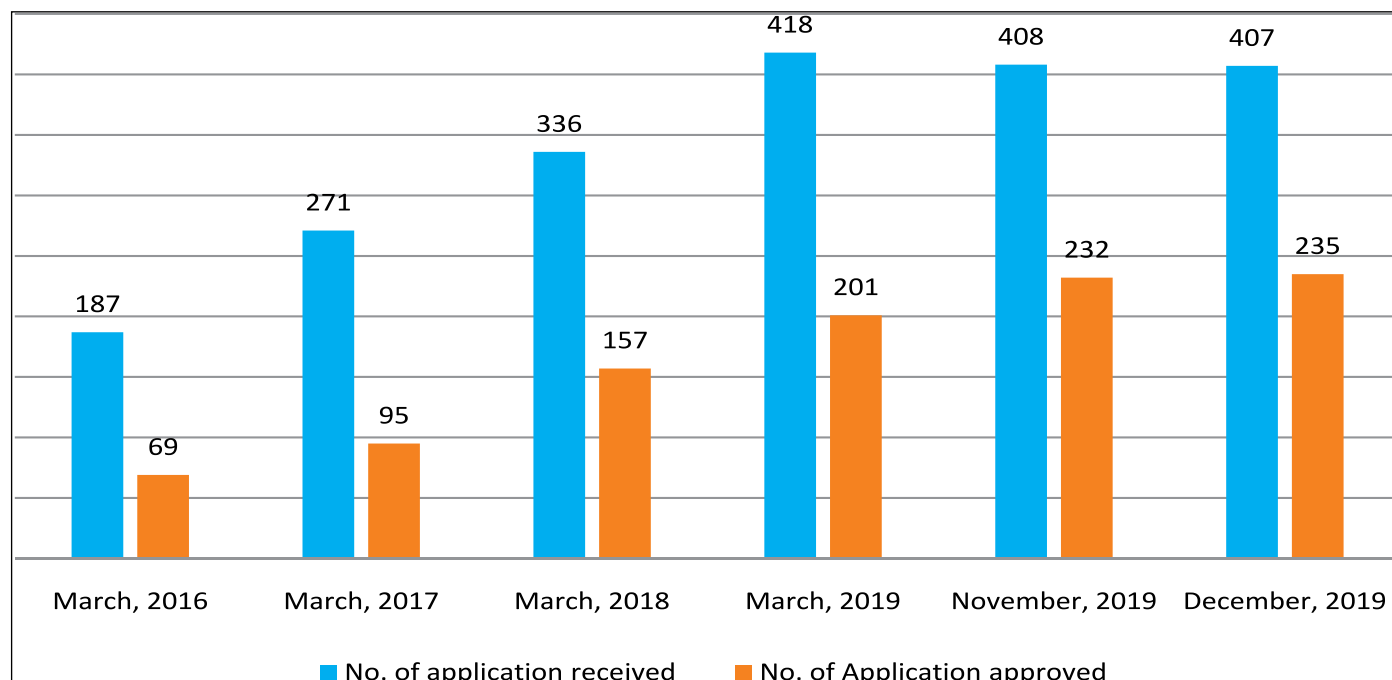

3.2 Electronics Manufacturing Clusters Scheme (EMC)

To create and strengthen the infrastructure ecosystem for electronics manufacturing, the Government notified EMC Scheme in October, 2012 to provide support for creation of world-class infrastructure for attracting investments in Electronics System Design and Manufacturing (ESDM) sector. The scheme was open for receiving applications for a period of five years from the date of its notification i.e. upto October, 2017. Further period of five years is available for disbursement of funds to the approved projects. Assistance for the projects in Greenfield Electronics Manufacturing Clusters is available upto to 50% of the project

cost subject to a ceiling of Rs. 50 crore for every 100 acres of land. For larger areas, pro-rata ceiling applies. At the lower end, the extent of support is decided by the Steering Committee for Clusters (SCC) subject to the ceiling of Rs. 50 crore. For Brownfield EMC (Common Facility Centre), 75% of the cost of infrastructure, subject to a ceiling of Rs. 50 crore is provided as grant.

Under the scheme, MeitY has approved twenty (20) applications for Greenfield EMCs and three (3) applications for Common Facility Centers (CFCs) in Brownfield Clusters measuring over an area of 3,565 acres with project cost of Rs. 3,898 crore including Grant-in-aid of Rs. 1,577 crore from Government of India. These EMCs are poised to

List of Final Approved Greenfield EMC

S. No.	State	Location/City
1	Andhra Pradesh	Village-Cherivi, Satyavedu Mandal, Chittoor District
2		Vikruthamala Village, Yerpedu Mandal, Chittoor District
3		Renigunta and Yerpedu Mandal, Chittoor District, Near Airport Tirupati
4	Assam	Bongora (Village), Chayani (Mouza), Palasbari (Revenue Circle), Kamrup (R) (District)
5	Chhattisgarh	Village-Tuta, Sector-22, Naya Raipur, Tehsil-Abhanpur, District- Raipur
6	Gujarat	Village-Tunda, Taluka- Mundra, District-Kutch
7	Goa	Village-Tuem, Taluka- Pernem, North Goa District
8	Jharkhand	Adityapur, Saraikela-Kharsawan District
9	Kerala	Kakkanad Village, Kanayannur Taluk, Ernakulam District
10	Madhya Pradesh	Badwai-Bhopal
11		Purva-Jabalpur
12	Odisha	Infovalley, Bhubaneswar Industrial Area, Khurda District
13	Rajasthan	SPL-1 Salarpur, Khuskhera, Bhiwadi
14		Karoli Industrial Area, Bhiwadi, Alwar District
15	Telangana	E-city, Fab City, Hyderabad
16		Maheshwaram, Ranga Reddy District
17	Uttar Pradesh	Plot No. 6/A, Sector-24, Yamuna Expressway
18		Plot No. -1, Block-C, Ecotech-VI Industrial Area, Greater Noida
19	West Bengal	Sector-IV & V, Falta Industrial Centre, P.S. Ramnagar, South 24 Parganas District
20		Naihati town, North 24 Parganas District

attract an investment of over Rs. 54,800 crore and are expected to generate employment opportunities for about 6.4 lakh persons once fully operational. These projects are currently under implementation. The details of approved EMCs are as under:

List of Approved Common Facility Centre (CFC)

S.No.	State	Location/City
1	Karnataka	Plot No. 336/4 & 336/5, Hebbal Industrial Area, Mysore
2	Maharashtra	Plot No.-P 30, Shendra Five Star Industrial Area, Aurangabad
3		Plot No. J/P-8, J 462 and J 462/P, Pimpri Industrial Area, Pune

The infrastructure development within these EMCs is currently under progress. Till 31st December, 2019, Grant-in-aid amounting to Rs. 520.88 crore has been released by MeitY to 20 EMCs for the infrastructure development activities within these EMCs.

Electronics manufacturers are showing their interest to set up their manufacturing operations within these EMCs. Approx. 185 units have booked about 756 acres of land for setting up of their manufacturing facilities within these EMCs. Out of these, 25 units have commenced commercial production with an investment of Rs. 4,730 crore in various verticals of electronics segment and have provided employment opportunities to over 12,000 persons. Further over 50 more companies are at various stages of implementation for setting up manufacturing operations within these EMCs.

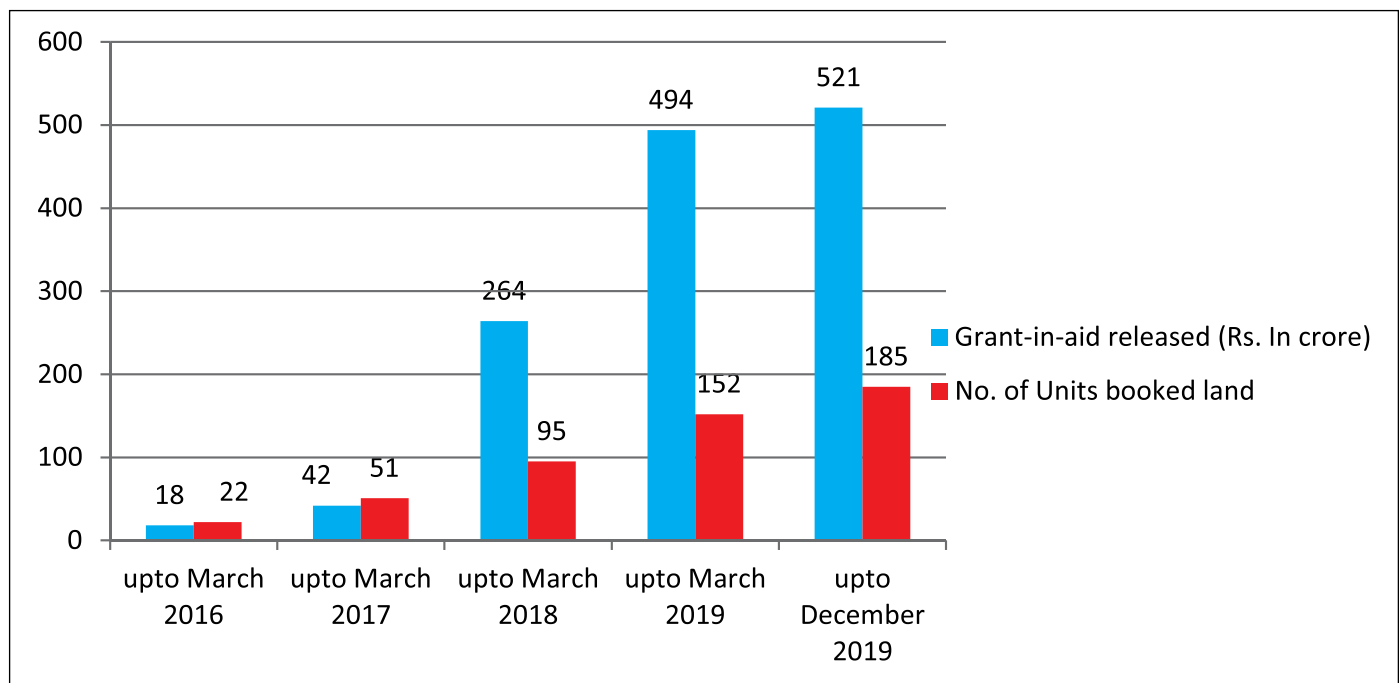

3.3 Electronics Development Fund (EDF)

Electronics Design & Manufacturing is a sector which is characterized by high velocity of technological change. Intellectual Property is possibly the most critical determinant of success, not only for the

companies of this sector but also to the countries and economies as a whole. Setting up of EDF was one of the important strategies which would enable creating an electronics industry ecosystem in the country. Creating a vibrant ecosystem of

innovation, Research and Development (R&D) with active industry involvement is essential for a thriving electronics industry. It is with this objective that an Electronics Development Fund (EDF) is set up as a “Fund of Funds” to participate in professionally managed “Daughter Funds” which in turn will provide risk capital to companies developing new technologies in the area of Electronics, Nano-electronics and Information Technology (IT). This fund is expected to foster R&D and innovation in these technology sectors. EDF enables creation of an ecosystem for providing risk capital to both industry and academia to undertake Research and Development in these technology areas. It will, in the process, enrich the intellectual property in the country and encourage more entrepreneurs towards product and technology development.

Canbank Venture Capital Funds Ltd. (CVCFL), a 100% subsidiary of Canara Bank, is the Investment Manager and MeitY is the anchor investor of EDF. EDF was launched on 15.02.2016 by Hon’ble Minister for Electronics & IT.

EDF is expected to invest in 11 Daughter Funds over a period of 4-5 years. The total targeted corpus of these 11 Daughter Funds is Rs. 5576 crore and the amount committed by EDF to these 11 Daughter Funds is Rs. 659 crore.

As on 30th November 2019, EDF has invested Rs. 117.89 crore in seven (07) Daughter Funds, which in turn have made investments of Rs. 560.98 crore in 75 Ventures/Startups. Total employment in supported Startups was 8,626. The details of investments of Daughter Funds are as follows:

(Rs. in crore)

Sl. No.	Name of Daughter Fund	Amount Invested by EDF	Total amount invested by the Daughter Fund in Startup /Companies	No. of investee start ups/Companies of the Daughter Fund
1	Endiya Seed Co-Creation Fund	24.33	115.88	12
2	KARSEMVEN Fund	13.12	44.15	10
3	YourNest India VC Fund II	11.71	43.40	7
4	PI Venture Fund-1	7.01	87.23	10
5	Unicorn India Ventures Fund-I	12.86	49.48	17
6	Aaruha Technology Fund-I	4.02	13.49	8
7	Venture East Proactive Fund II	44.84	207.35	11
	Total	117.89	560.98	75

3.4 Compulsory Safety Standards for Electronics

The “Electronics and Information Technology Goods (Requirements for Compulsory Registration) Order, 2012” was notified on 3rd October, 2012 under the provision of Compulsory Registration Scheme of BIS Act, 1986, in order to protect safety of Indian consumers and to curb the inflow of substandard electronic products. The Order necessitates creation of institutional mechanism for developing

and mandating standards and certification for electronic products to strengthen Conformity Assessment infrastructure nationwide.

As per the provisions of the Order, the product notified under the schedule of the Order need to be registered with Bureau of Indian Standards (BIS), based on safety test report as per the Indian Standards issues by BIS recognized laboratories before import into the country or sale in Indian market. The registration can only be granted to

manufacturers for a particular location. In order to check compliance of the Order, random surveillance is carried out by MeitY. At present, 44 products categories (including Indian Language support for Mobile Phones as per IS 16333 (Part 3)) have been added to the schedule of the Order in a phased manner and the order has come into effect for all the notified product categories.

The Compulsory Registration Scheme has resulted in high compliance of notified electronic goods to Indian safety standards and more than 20,700 registrations have been granted by BIS to manufacturing units covering approximately one lakh products models/series.

Scheme for setting up/up-gradation of Electronic products testing/Quality Control Laboratories

To strengthen the conformity assessment infrastructure, MeitY notified “Scheme for setting up/up-gradation of Electronic product testing/Quality Control Laboratories” on 25th August 2013 with the objective to encourage setting up of testing facilities by Central/State/Academic Institutions for evaluating goods under the “Electronics and Information Technology Goods (Compulsory Registration Order) 2012. The following project proposals have been approved:

- CEC, IIT Madras, Chennai for total GIA of Rs. 140 lakh.
- CSIR, Central Institute of Mining and Research (CIMFR), Dhanbad for total GIA of Rs. 142.75 lakh.
- MPSEDC, Bhopal for total GIA of Rs. 127.50 lakh.
- NRTC, Parwanoo for total GIA of Rs. 140.27 lakh.
- Institute for Design of Electrical Measuring Instruments (IDEMI), Mumbai for total GIA of Rs. 150 lakh.

3.5 Growth of Electronics Sector:

The Government attaches high priority to electronics hardware manufacturing, and it is one of the important pillars of both “Make in India” and “Digital India” programmes of Government of India. Besides the economic imperative, focus on electronics hardware manufacturing up to the integrated circuit or chip level is required due to the growing security concerns.

As a result of various steps taken by the Government of India for promotion of electronics hardware manufacturing and efforts of the industry, India’s electronics production has increased from Rs. 1,90,336 crore in 2014-15 to an estimated Rs. 5,46,550 crore during 2019-20, at a Compound Annual Growth Rate (CAGR) of about 24%.

Indian electronics industry saw a significant milestone in the year 2016-17, when domestic production of electronic goods exceeded their import. Thereafter, the trend has continued, as given in the following table, which implies that policies/schemes formulated for promotion of domestic electronics manufacturing and the “Make in India” initiative have started giving positive results.

Import, Export and Production of Electronic Goods (in USD billion)

Year	Import	Export	Production
2014-15	38	6.2	29
2015-16	41	5.9	37
2016-17	43	5.9	49
2017-18	53	6.4	60
2018-19	57	8.8	70

The import of electronic goods was about USD 57 billion in 2018-19 and with the demand for electronics hardware expected to rise rapidly to about USD 400 billion by 2025, India cannot afford to bear a huge foreign exchange outgo on import of electronics alone. Therefore, promoting domestic electronics hardware manufacturing, with high value addition is of vital importance.

The National Policy on Electronics 2019 (NPE 2019) has been notified on 25.02.2019. The NPE 2019 replaces the NPE 2012. NPE 2019 envisions positioning India as a global hub for Electronics System Design and Manufacturing (ESDM) by encouraging and driving capabilities in the country for developing core components, including chipsets, and creating an enabling environment for the industry to compete globally. The goal is to strengthen India’s linkages with global trade, integrate with global value chains and build facilitative programmes and incentive framework to promote domestic value addition and boost electronics exports.

India, with its huge market and unique location at the crossroads of the East and West offers huge opportunity to be developed as a manufacturing hub for electronics - both for catering to domestic demand as well as for exports. Electronics sector has several verticals in terms of its main constituents. Each vertical has its unique manufacturing characteristics/processes and the associated challenges. Based on the data available from various Industry Associations, the year-wise production profile of electronics sector is as under:

Electronics industry is going through an exciting phase due to revolutionary changes in technology, launch of innovative products and the challenge of global competition. Constant miniaturization of products would lead to the creation of smaller devices and components, while convergence would lead manufacturers to integrate multiple devices into one.

The recent initiative of reduction in corporate income tax rates and incentive to new manufacturing units will give a boost to the “Make in India” programme and place India at a competitive footing with other major global electronics manufacturing hubs. Domestic companies can now opt for concessional tax regime @22% (25.17% inclusive of surcharge and cess) provided that such a company has not claimed any income tax incentive or exemption. Further, to attract fresh investments in manufacturing and boost “Make in India” programme, a new provision has been made which allows new domestic companies incorporated on or after October 1, 2019, making fresh investment in manufacturing, and starting operations before March 31, 2023, an option to pay corporate income tax @15% (17.16% inclusive of surcharge and cess). This shall be a game changer

Production Profile of Electronics Sector

(in Rs. crore)

Sl. No.	Item / Vertical	2014-15	2015-16	2016-17	2017-18	2018-19	2019-20*
1.	Consumer Electronics	55,806	55,765	64,742	73,524	77,000	84,000
2.	Industrial Electronics	39,374	45,083	62,214	69,057	80,850	92,200
3.	Computer Hardware	18,691	19,885	20,382	21,401	21,180	22,500
4.	Mobile Phones	18,900	54,000	90,000	1,32,000	1,70,000	2,25,000
5.	Strategic Electronics	15,700	18,055	20,760	23,562	28,270	32,800
6.	Electronic Components	39,723	45,383	52,099	59,132	67,706	75,800
7.	Light Emitting Diode (LED) Products	2,172	5,092	7,134	9,630	13,000	16,250
	Computed Total	1,90,366	2,43,263	3,17,331	3,88,306	4,58,006	5,46,550

* Estimated

Notes: (1) Aforesaid data is provided by the respective Electronics Industry Associations.

(2) Source: For 2,5,6& 7 -Electronic Industries Association of India (ELCINA); 4 -India Cellular and Electronics Association (ICEA); 1&3 -Estimates based on inputs of Consumer Electronics and Appliances Manufactures Association (CEAMA)&Manufacturers’ Association of Information Technology (MAIT), respectively

for the Make in India initiative since it was one of the major issues raised by the potential investors.

Consumer Electronics

Growing awareness, easier access, growing middle class with increasing disposable incomes, changing lifestyles, reduction of GST rate from 28% to 18% on Televisions upto 32”, refrigerators, washing machines and microwave ovens and allowing 51% Foreign Direct Investment (FDI) in multi-brand retail and 100% FDI in single-brand retail have been the key growth drivers for the consumer market. Indian consumer durables industry is poised at a very interesting juncture at present and India has the potential to become an attractive investment destination for investment in this sector.

Demand for durables like refrigerators as well as consumer electronic goods like Televisions shall witness significant growth in the rural markets as well in the coming years. Television plays an important role in home consumer electronics. The television market currently consists of televisions that cover a wide range of new technologies that go beyond the conventional cathode ray tube (CRT) format. Increasing innovation coupled with decreasing prices has augmented the penetration of flat panel display TVs across all income groups in the country. Usage of television is no longer an urban phenomenon now with penetration of television in rural India having grown exponentially. TV manufacturers have rapidly adopted marketing of Liquid Crystal Display (LCD)/ Light Emitting Diode (LED) TVs as they offer sharper, higher resolution pictures. With the decreasing trend in the prices of LCD/LED televisions, the penetration of these TVs is increasing significantly. The domestic production of LCD/LED TVs has gone up from 0.87 crore units in 2014-15 to 1.20 crore units in 2018-19. About 38 units are manufacturing LCD/ LED Televisions in the country.

The reduction of Basic Customs Duty (BCD) levied on Open Cell used in the manufacture of LCD/ LED

TV Panels from 5% to Nil has led to reduction in prices, thereby boosting the demand, which would be met primarily through domestic manufacturing.

The domestic production of consumer electronics has gone up from Rs. 77,000 crore in 2018-19 to an estimated Rs. 84,000 crore in 2019-20.

Industrial Electronics

Industrial electronics is an empirical barometer of overall growth in the contribution of the manufacturing sector in the economy. The spurt in investments due to the “Make in India” programme is bringing significant interest in engineering, electrical, automotive and electronics segments which are the driving force behind the growth of industrial electronics sector in the country. The key application segments of the industrial electronics industry are process control equipment, test and measuring equipment, power electronics equipment, automation and analytical instruments. These technologies are gaining ground as modernization, automation and robotics are the future growth areas.

Power electronics space is dominated by unorganized regional players, which is expected to grow at higher rate due to huge demand and low penetration. Inverters and UPS are also becoming household items driving the growth of this segment. Some of the Indian players have set up global tie-ups over the last few years and have brought in newer technologies into the Indian industry. Solar Photovoltaic and allied equipment is another segment which is likely to grow at a sustained high growth rate.

As a secondary demand constituent, industrial electronics segment is dependent on overall growth in GDP and rate of growth of manufacturing. The industrial electronics sector is witnessing growth due to enhanced digitization and robotics applications in the Industry. Additionally, the impetus on Smart Cities and Internet of Things (IoT) will bring a whole

new focus and demand for smart and automation electronics.

The domestic production of industrial electronics has gone up from Rs. 80,850 crore in 2018-19 to an estimated Rs. 92,200 crore in 2019-20.

Computer Hardware

Computer hardware products are broadly classified as computing products, viz., Desktop PCs, Notebooks, Servers; Printing and Imaging products and Peripherals, viz., UPS, keyboard and mouse, monitor and displays; Networking products; Storage products and components.

As per IDC projections, the global Desktop - Laptop market during 2019-2023 is likely to experience de-growth by 0.4% in numbers but in terms of value it is expected to be flat which implies high unit value and hence, more value addition.

India's PC penetration of 15 per 1000 people is very low as compared to USA (784 for 1000 people) and China (41 per 1000 people) which reflects the growing opportunity in India. Similarly, the usage of the computers and its peripherals in commercial and industrial establishments and offices is likely to grow at a steady pace. Similarly, with the availability of 5G networking capability, network equipment (Routers, Switches, WLAN) are poised for a fast growth in the coming decade.

The domestic production of computer hardware has gone up from Rs. 21,180 crore in 2018-19 to an estimated Rs. 22,500 crore in 2019-20.

Mobile Phones

India has gradually built its mobile handsets manufacturing capability on the back of supportive policies like the Phased Manufacturing Programme (PMP), Modified Special Incentive Package Scheme (M-SIPS) and the growing domestic

market. Domestic manufacturing of cellular mobile handsets and its sub-assemblies/ parts has emerged as one of the flagship sectors under the "Make in India" initiative of the Government. As a result of implementation of the PMP, the sector is steadily moving from Semi Knocked down (SKD) to Completely Knocked Down (CKD) level of manufacturing.

Mobile handset ecosystems are largely organized around a few "motherships" which essentially combine brands and their unique supply chains. The sub-assembly and component manufacturing ecosystems move when the "mothership" sets up a large-scale manufacturing base in a country. India is now home to the manufacturing ecosystems for Samsung, Apple, Oppo, Vivo, Xiaomi, etc. and this is leading to the development of a mature supplier ecosystem in the country with large-scale investments. As per India Cellular and Electronics Association (ICEA), the production of cellular mobile handsets has gone up from 6 crore units valued at Rs. 18,900 crore in 2014-15 to an estimated 32 crore units valued at Rs. 2,25,000 crore in 2019-20. National Policy of Electronics 2019 also envisages that India has the potential to produce 1 billion mobile handsets valued at USD 190 billion by 2025, out of which 600 million handsets valued at USD 100 billion could be exported.

India has already become the second largest mobile handsets manufacturing nation globally. India has also become the second largest smart phone market globally. India's rise as the fastest growing smart phone market in the world has given rise to innumerable opportunities in manufacturing and applications development eco-system.

The Government of India provides utmost priority to promotion of electronics manufacturing in the country, with particular focus on the development of mobile handsets and their sub-assemblies/ parts/ components manufacturing eco-system, which has assumed greater significance under the "Make

in India” and “Digital India” flagship programmes. Some of the important initiatives undertaken by the Government for development of this sector are:

- i. Imposition of 20% BCD on mobile handsets to encourage their domestic manufacturing.
- ii. Establishment and implementation of the Phased Manufacturing Programme (PMP) roadmap which has led to imposition of BCD in the range of 10% - 20% on notified sub-assemblies of mobile handsets to encourage their domestic manufacturing.

As per Industry projections, the global market size of mobile handsets is expected to grow from USD 495 billion in 2019 to USD 640 billion in 2025 and there is indeed a tremendous potential in mobile handsets manufacturing eco-system for the nation in future in terms of employment generation, value addition and foreign exchange savings.

The domestic production of mobile phones has gone up from Rs. 1,70,000 crore in 2018-19 to an estimated Rs. 2,25,000 crore in 2019-20.

Strategic Electronics

Strategic Electronics constitutes sectors like Defence, Nuclear and Aerospace and all these sectors are poised for high growth considering the current economic conditions. Electronics has always been an important element of the defence sector, in enabling communications, intelligence gathering and navigation. The strategic electronics sector differs from others in its reliability requirements and the need to support products for extended periods. Security is also a vital and non-negotiable parameter in defense equipment like radar, electronic warfare system, autonomous weapons, military communication system, disaster management system, internal security systems, etc. Hence, there have not been many domestic electronic manufacturing companies in the defence sector which could absorb the technology and meet the stringent requirements, but lately, with the

encouragement of the Government some small as well as large units have come up in this sector.

Production of strategic electronics has increased from Rs. 15,700 crore in 2014-15 to Rs. 28,270 crore in 2018-19 with a CAGR of about 16%. The demand is expected to grow to about USD 8.9 billion by 2025. Key growth drivers include modernization of defence, Defence Procurement Policy (DPP), Technology Development Fund (TDF) and purchase of new defense equipment in the coming years. Government has plans to increase the indigenization component from current level of 45% to 75% in the sector, and to achieve the same, all Defence Public Sector Undertaking have set ambitious targets for indigenization.

The domestic production of strategic electronics has gone up from Rs. 28,270 crore in 2018-19 to an estimated Rs. 32,800 crore in 2019-20.

Electronic Components

According to Industry estimates, the global market for electronic components is expected to reach USD 191.8 billion, out of which the Asia Pacific region is expected to capture a dominant share and consequently India's Electronic components market is also poised for a significant growth. According to ELCINA, the size of Indian electronics components market has increased from USD11 billion in 2015-16 to USD25.3 billion in 2018-19 (excluding the imported PCB Assemblies) with a CAGR of 32%.

Electronic components are the basic building blocks for Electronics Industry and entail maximum value addition. Despite the high reliance on imports, India's electronics sector has witnessed rapid growth in recent years and the expected rollout of technological innovations of 5G, IoT, Robotics and introduction of electric vehicles would further accelerate the adoption of electronics. Mobile phones, consumer electronics and industrial electronics segments account for the major demand of about 85% for electronic components in India.

The policies and schemes introduced by the Government of India during the last few years such as the Phased Manufacturing Programme (PMP), Modified Special Incentive Package Scheme (M-SIPS) and notification of electronics products under the Public Procurement (Preference to Make in India) Order, rationalization of tariff structure and increasing BCD on Mobile Phones, LED Lights, Flat Panel TVs, Set Top Boxes (STBs), Energy Meters and Microwave Ovens etc. has led to increase the manufacturing of these products and their components.

Similarly, BCD was imposed on Printed Circuit Board (PCB) Assemblies with intent to strengthen the domestic Electronic Manufacturing Services (EMS) and components segment in India. Lately, EMS industry in India has grown rapidly and key global players as well as a number of domestic companies have started operations in the country. For a sustainable business model this segment needs very high efficiency of operations. Hence, availability of components and an effective supply chain is vital for EMS companies for their growth. Till now, domestic companies have generally followed the business model of staying in low-volume and high-mix business segments, where the margins are better. However, the EMS players need to operate in high-volume and low-margin segments to compete with the global players. Therefore, Made in India products need to extend their reach to Global markets and hence exports need to be stepped up significantly. Government is working on policies/ schemes to develop electronic components manufacturing base in the country and encourage exports.

Presently, Indian electronic components production is dominated by electro-mechanical and passive components such as printed circuit boards, connectors, wound components, capacitors, resistors, etc. and the percentage share of active components (such as diodes, transistors,

Integrated Circuits, etc.) and the associated components (such as optical disc, magnets, RF tuners, etc.) is low. In the recent past, mobile handsets sector has given a thrust to electronic components manufacturing in the country. Domestic manufacturing of electronic components shall increase value addition and also bring down the cost of production of electronic goods. India has the potential to become a the global hub for active components also due to availability of cost effective skilled manpower, improved infrastructure and Government's push for ease of doing business in India. Also, a strong components manufacturing base is a pre-requisite for a vibrant electronics manufacturing sector in India.

The domestic production of electronic components has gone up from ₹ 67,706 crore in 2018-19 to an estimated ₹ 75,800 crore in 2019-20.

Light Emitting Diode (LED) Products

Globally the demand for lighting products has witnessed a surge in recent years on account of growing population and rapid urbanization, However, due to global climate change, governments across the globe have started focusing on use of energy efficient devices, as a result of which there is a growth in demand for energy efficient products based on Light Emitting Diodes (LEDs). As per industry estimates, global LED lighting and fixture market has grown at a CAGR of 15.4 % during the period 2015 - 2018.

Over the years, due to the significant reduction in prices, opportunities for LEDs have emerged in sectors like automotive, communications, signaling, and entertainment. With increased awareness, the demand for LEDs has increased significantly in both residential and commercial segments. Outdoor applications such as street lighting, etc. is a promising area of growth for Indian LED lighting industry.

India is the second most populous country in the world and yet, is only the fifth largest electricity consumer, a situation that has led to an ever-widening demand-supply gap. Consequently, the market for energy efficient products such as LED lighting is bound to grow. The aim of Government of India is also to reduce the high cost of electrification and simultaneously reduce the high emission emerging from energy inefficient devices.

The Indian LED lighting market stood at USD 918.70 million in 2016 in value terms and is expected to reach US\$ 3.76 billion by 2022, on account of increasing government initiatives to boost LED adoption and growing awareness regarding lower power consumption of LED lighting products. Moreover, easy availability of LED lighting products at low prices, coupled with the aggregation of demand of LED bulbs by EESL and projects like Smart Cities and housing for all is fueling the demand for such products.

The domestic production of LED products has gone up from ₹ 13,000 crore in 2018-19 to an estimated ₹ 16,250 crore in 2019-20.

Automotive Electronics

High-tech systems started appearing in cars in the 1980s, and today, auto electronic systems and engine computers do everything from regulating fuel to diagnosing problems. Most of today's cars have between 30-80 separate electronic controllers. Due to pervasive electronics systems in automobile operations, manufacturers have been able to improve the driving performance, fuel efficiency, and both the driver's and riders' comfort. Modern cars are equipped with hundreds of electronic systems which are used in safety airbags, anti-lock brake, radio, music system, telematics, parking ability, and in most of the car operations. Integration of electronics in core engineering of cars such as the engine, its transmission, brakes, and auto control steering would continue to expand.

Automotive Mission Plan 2016-26 targets India to be among the top three in the world for engineering, manufacturing and export of vehicles and auto components. The growing presence of global automobile Original Equipment Manufacturers (OEMs) in the Indian manufacturing landscape has significantly increased the localization of their components in the country. India has become the preferred designing and manufacturing base for most global auto OEMs for local sourcing and exports. Incentives from the government, rising disposable incomes and lower auto financing interest rates, are the key factors expected to drive the automotive industry in the country. Automotive Components Manufacturing Association (ACMA) has projected that Indian automotive electronics sector will reach approximately INR 36,500 crore by 2020. The global market for automotive electronics is estimated to be about USD 230 billion in 2020. This presents a huge opportunity for promoting domestic manufacturing of automotive electronics in the country.

Medical Electronics

Governments of most developing countries have laid emphasis on provision of good quality, affordable and comprehensive healthcare to all their citizens. While healthcare infrastructure and human resources are areas in which most countries have achieved self-sufficiency, Medical Devices is an area where focused attention is needed.

Global medical health care devices market was about USD 160 billion in 2017 and is expected to grow at a CAGR of over 16% during 2010-2025, due to rising prevalence of chronic diseases, ageing population, increasing income and affordability, resulting in higher demand and utilization of healthcare services.

Indian medical devices market is approximately USD 6.4 billion and is estimated to become over USD 10 billion in 2022 and USD 25 billion by 2025. The Indian medical devices market is among the

top twenty in the world by market size, and fourth in Asia, after Japan, China and South Korea. Currently, there are about 800 medical device manufacturers in the country, with an average investment of ₹ 17-20 crore and an average turnover of ₹ 45-50 crore. The Indian medical device market is expected to record remarkable growth and will continue to reduce its dependence on imports, as domestic manufacturing develops under the “Make in India” initiative.

Key drivers for the growth of domestic manufacturing in medical devices include:

- Expected increase in health care spending from current 1.4 % of GDP to 3% by 2025
- Roll out and continued improvisation of the Ayushman Bharat Scheme
- 100% FDI allowed in medical devices sector
- Speedy policy measures to address the challenges faced by medical device industry
- Preferential market access in Public Procurement

In addition, to promote scientific and technological research in medical electronics sector in India, MeitY in association with Biotechnology Industry Research Assistance Council (BIRAC) is implementing Industry Innovation Programme on Medical Electronics (IIPME). The Project aims to fund a portfolio of Indian led pilot projects that target innovations in the multi-disciplinary areas, comprising of electronics, engineering, medical devices, healthcare, software, algorithms and information technology.

Exports

Government has taken several measures for the growth of the exports of electronics hardware sector. Special Economic Zones (SEZs) that have been set up to enable hassle-free manufacturing and trading for export purposes and Electronics Hardware Technology Park (EHTP) units are the major contributors to exports.

Merchandise Exports from India Scheme (MEIS) benefits are available for export of electronic goods under the Foreign Trade Policy. The other schemes for export promotion are Export Promotion Capital Goods (EPCG) Scheme, Duty Exemption and Remission Schemes, Duty Free Import Authorization (DFIA) Scheme, Deemed Exports, etc.

As per the Directorate General of Commercial Intelligence and Statistics (DGCI&S) data, the export of electronic goods has gone up significantly to USD 8,829 million (₹ 61,908 crore) during 2018-19, as compared to USD 6,363 million (₹ 41,220 crore) during 2017-18, driven mainly by increasing mobile phone exports from the country.

Imports

As per DGCI&S data, the total import of electronic goods into India was USD 57,378 million (₹ 4,01,458 crore) in 2018-19, as compared to the import of USD 52,891 million (₹ 3,40,901 crore), during the preceding year 2017-18.

3.6 Public Procurement (Preference to Make in India) Order 2017

The Government has issued Public Procurement (Preference to Make in India) Order, 2017 vide Department of Promotion of Industry and Internal Trade (DPIIT) Notification No. P-45021/2/2017-B.E.-II dated 15.06.2017 to encourage ‘Make in India’ and to promote manufacturing and production of goods and services in India with a view to enhancing income and employment.

In furtherance of the aforesaid Order, Ministry of Electronics and Information Technology has issued Notification for 11 Electronic Products viz., Desktop PCs, Laptop PCs, Tablet PCs, Dot Matrix Printers, Contact and Contactless Smart Cards, LED Products, Biometric Access Control/ Authentication Devices, Biometric Fingerprint Sensors, Biometric Iris Sensors, Servers and cellular mobile phones, vide Notification No.33(1)/2017-IPHW dated 14.09.2017 and Notification No. 33(5)/2017-IPHW

dated 01.08.2018, for providing preference to domestically manufactured electronic products.

3.7 Tariff Rationalization:

Rationalization of Tariff Structure is an on-going process. Tariff Structure has been rationalized to promote domestic manufacturing of electronic goods, including, inter-alia, Cellular mobile handsets, Televisions, Electronic components, Set Top Boxes for TV, LED products and Medical electronics equipment. To promote domestic value addition in mobile handsets and their parts/ components manufacturing, a Phased Manufacturing Programme (PMP) has been notified. As a result, India has rapidly started attracting investments into this sector and significant manufacturing capacities have been set up in the country during the past four to five years. The manufacturing of mobile handsets and their parts/ components has been steadily moving from Semi Knocked Down (SKD) to Completely Knocked Down (SKD) level, thereby progressively increasing the domestic value addition.

Key tariff interventions to promote domestic manufacturing of electronic goods are as under:

Basic Customs Duty (BCD) exemption on Open Cell (15.6" and above) for use in the manufacture of Liquid Crystal Display (LCD) and Light Emitting Diode (LED) TV Panels

To promote domestic manufacturing of TV Panels, the BCD levied on Open Cell (15.6" and above) for use in the manufacture of Liquid Crystal Display (LCD) and Light Emitting Diode (LED) TV Panels has been reduced to Nil from 5% vide Customs Notification No.30/2019 dated 17.09.2019 till September 2020. BCD has also been exempted on following inputs to promote domestic manufacturing of Open Cells:

- o Chip on Film
- o Printed Circuit Board Assembly (PCBA)
- o Cell (glass board/substrate)

Basic Customs Duty (BCD) exemption on capital goods for use in the manufacture of specified electronic goods

BCD has been exempted on specified capital goods [falling under Chapter 82, 84, 85 and 90] for use in the manufacture of specified electronic goods such as Printed Circuit Board (PCB), Charger of cellular

S. No.	Item	HS Code	BCD upto 13.12.17	BCD w.e.f. 14.12.17
1	Cellular Mobile Handsets	85171210 85171290	10%	15% (further increased to 20% in Budget 2018-19)
2	Set Top Box for Television	85287100	10%	20%
3	Colour Televisions	852872	10%	20%
4	Microwave Ovens	85165000	10%	20%
5	Digital Video Recorder (DVR)/ Network Video Recorder (NVR)	85219090	10%	15% (further increased to 20% in Budget 2019-20)
6	CCTV Camera/ IP Camera	852580	10%	15% (further increased to 20% in Budget 2019-20)
7	Light Emitting Diode (LED) Lamps	85395000	10%	20%
8	Smart Meters	902830	10%	15%
9	w.e.f. 30.01.2019, BCD on Power Banks (HS 85076000) has also been increased from 10% to 20%.			

mobile phones, Display Panel, etc. subject to actual user condition, vide Notification No.22/2019-Customs dated 06.07.2019.

Phased Manufacturing Programme (PMP) for cellular mobile handsets and sub-assemblies/ parts/ components thereof

Mobile handsets manufacturing has emerged as a key sector under the “Make in India” initiative of the Government. The production of mobile handsets has gone up from approx. 60 million units valued at USD 3 billion in 2014-15 to approx. 290 million units valued at USD 26 billion in 2018-19. Over 260 units are manufacturing cellular mobile handsets and their sub-assemblies/ parts in India. India has emerged as the second largest manufacturer of mobile handsets in the world. Most of the major brands (both foreign and Indian) have either already set up their own manufacturing facilities or have sub-contracted manufacturing to Electronics Manufacturing Services (EMS) companies operating from India. Rapid growth of 38% Y-o-Y in 2018-19 in electronics exports has been witnessed, driven by export of mobile handsets.

The Excise Duty based Phased Manufacturing Programme (PMP) was formulated and implemented in 2016-17 for Charger/Adaptor, Battery Pack and Wired Headset, with the objective to substantially increase the domestic value addition for establishment of a robust cellular mobile handsets manufacturing eco-system in India. As a result, India rapidly started attracting investments into this sector and significant manufacturing capacities have been set up in India during the past four to five years. The following PMP roadmap, formally notified in April 2017, has enabled the cellular mobile handsets and related sub-assembly/ component industry to plan their investments in the sector. Presently, the PMP has been implemented based on Basic Customs Duty (BCD) based differential duty in favour of domestic manufacturers:

Year	Sub-Assembly
2016-17	(i) Charger/ Adaptor, (ii) Battery Pack, (iii) Wired Headset
2017-18	(iv) Mechanics, (v) Die Cut Parts, (vi) Microphone and Receiver, (vii) Key Pad, (viii) USB Cable
2018-19	(ix) Printed Circuit Board Assembly (PCBA), (x) Camera Module, (xi) Connectors
2019-20	(xii) Display Assembly, (xiii) Touch Panel/ Cover Glass Assembly, (xiv) Vibrator Motor / Ringer

Summary of key tariff changes in the Budget 2020-21 for Electronics Sector is as under:

- BCD on Printed Circuit Board Assembly (PCBA) of cellular mobile phones (HS 85177010) is being increased from 10% to 20% with effect from 01.04.2020 by increasing the tariff rate (Clause 115 (a) of the Finance Bill, 2020 refers). The existing BCD rate of 10% on PCBA of cellular mobile phones shall continue upto 31.03.2020. Notification No.2/2020-Customs dated 02.02.2020, inserting new S.No.21 in Notification No.57/2017-Customs dated 30.06.2017 refers.
- BCD@10% shall be levied on the Vibrator Motor/ Ringer for use in the manufacture of cellular mobile phones w.e.f. 01.04.2020. Inputs or parts and their sub-parts for use in the manufacture of Vibrator Motor/ Ringer shall also be exempted from BCD w.e.f. 01.04.2020. Notification No.2/2020-Customs dated 02.02.2020, inserting new S.No.5C in Notification No.57/2017-Customs dated 30.06.2017 refers.
- BCD@10% shall be levied on the Display Assembly for use in the manufacture of cellular mobile phones w.e.f. 01.10.2020. Inputs or parts and their sub-parts for use in the manufacture of Display Assembly

shall also be exempted from BCD w.e.f. 01.10.2020. Notification No.2/2020-Customs dated 02.02.2020, inserting new S.No.5D in Notification No.57/2017-Customs dated 30.06.2017 refers.

- BCD@10% shall be levied on the Touch Panel/ Cover Glass Assembly for use in the manufacture of cellular mobile phones w.e.f. 01.10.2020. Inputs or parts and their sub-parts for use in the manufacture of Touch Panel/ Cover Glass Assembly shall also be exempted from BCD w.e.f. 01.10.2020. Notification No.2/2020-Customs dated 02.02.2020, inserting new S.No.5E in Notification No.57/2017-Customs dated 30.06.2017 refers.
- BCD has been exempted on specified parts of Microphones (covered under HS 85181000) viz. (i) Microphone Cartridge; (ii) Microphone Holder; (iii) Microphone Grill; and (iv) Microphone Body, subject to actual user condition. Notification No.1/2020-Customs dated 02.02.2020, inserting new S.No.489B in Notification No.50/2017-Customs dated 30.06.2017 refers.
- BCD has been exempted on Micro Fuse Base, Sub-Miniature Fuse Base, Micro Fuse Cover and Sub-Miniature Fuse Cover (covered under HS 8538) for use in the manufacturing of Micro Fuse and Sub-Miniature Fuse, subject to actual user condition. S.No.190 of the Notification No.25/1999-Customs dated 28.02.1999, as amended vide Notification No.5/2020-Customs dated 02.02.2020 refers.
- BCD has been exempted on Liquid Crystal Polymer (LCP) (HS 39079990) for use in the manufacture of Connectors, subject to actual user condition. S.No.225 of Notification

No.25/1999-Customs dated 28.02.1999, as amended vide Notification No.5/2020-Customs dated 02.02.2020 refers.

- BCD on charger or power adapter (except those covered in Information Technology Agreement-1) covered under HS 850440 has been increased from Nil/10%/15% to 20% by increasing the tariff rate on the items covered under HS 850440 from 10%/15% to 20% (Clause 115 (a) of the Finance Bill, 2020 refers). All goods other than charger or power adapter, covered under HS 850440 will continue to attract 10% BCD. S.No.13 of Notification No.57/2017-Customs dated 30.06.2017, as amended by Notification No.2/2020- Customs dated 02.02.2020 refers.
- A new HS Code 85299030 has been created for “Open cell for television set” (Clause 115(b) of the Finance Bill, 2020 refers). The existing BCD exemption on Open cell (15.6” and above) shall continue under S.No.515A of Notification No.50/2017-Customs dated 30.06.2017.
- BCD exemption has been withdrawn on the Fingerprint readers/ scanner (covered under HS 85177090) for use in the manufacture of cellular mobile phones vide Notification No.1/2020-Customs dated 02.02.2020, amending S.No.468 of Notification No.50/2017-Customs dated 30.06.2017. Consequently, the aforesaid said goods will attract applicable BCD rate. However, BCD has been exempted on inputs or raw material for the manufacture of such Fingerprint readers/ scanners vide S.No.7 of Notification No.57/2017-Customs dated 30.06.2017, as amended vide Notification No.2/2020-Customs dated 02.02.2020.

- Health Cess has been imposed at the rate of 5% on import of medical devices falling under headings 9018 to 9022 w.e.f. 02.02.2020 (Clause 139 and Fourth Schedule of the Finance Bill, 2020 refers). However, Health Cess has been exempted on medical devices which are exempt from BCD including under FTA notifications. Further, inputs/ parts used in the manufacture of medical devices are also exempted from Health Cess. Notification No.8/2020-Customs dated the 02.02.2020 refers. Health Cess has been imposed for financing the health infrastructure and services. Export Promotion scrips shall not be used for payment of Health Cess.
- BCD on all headphones and earphones (covered under HS 85183000) has been increased from applicable rate to 15%. Earlier, only headsets of cellular mobile phone (covered under HS 85183000) were attracting 15% BCD. S.No.18 of Notification No.57/2017-Customs dated 30.06.2017, as amended vide Notification No.2/2020-Customs dated 02.02.2020 refers.
- BCD has been decreased from 10% to 5% on Calendared Plastics Sheet (HS 39201099) for use in the manufacture of Smart Cards (HS 8523), subject to actual user condition. New S.No.277A inserted in Notification No.50/2017-Customs dated 30.06.2017 vide Notification No.1/2020-Customs dated 02.02.2020 refers.
- BCD has been increased from 7.5% to 10% on all goods (including Motors of an output not exceeding 37.5 Watt) covered under HS 8501 (except tariff items 85016470 and 85016480) by omitting entry at S.No.486 of Notification No.50/2017-Customs dated 30.06.2017

vide Notification No.1/2020-Customs dated 02.02.2020.

3.8 National Policy on Electronics (NPE) 2019

The National Policy on Electronics (NPE) 2019 has been formulated to reflect the new aspirations, requirements and realities of the electronics manufacturing sector in the country and the emerging international dynamics and its notification dated 25.02.2019 was published in the Gazette of India on 02.03.2019. The aim of NPE 2019 is as follows:

The salient features of NPE 2019 inter-alia include:

- Creating eco-system for globally competitive ESDM sector
- Promotion of electronic components manufacturing ecosystem
- Special package of incentives for Mega Projects which are extremely high-tech and entail huge investments, such as semiconductor facilities (including trusted foundries), display fabrication, photonics and LED chip fabrication units
- Encouraging Industry-led R&D and innovation and promoting start-up eco-system in all sub-sectors of electronics, including emerging technology areas such as 5G, IoT/ Sensors, Artificial Intelligence (AI), Machine Learning, Augmented Reality (AR) and Virtual Reality (VR), Drones, Robotics, Additive Manufacturing, Gaming and Entertainment, Photonics, Nano-based devices, as well as thrust areas such as medical electronics, defence and strategic electronics, automotive electronics, cyber security, power electronics and automation
- Providing incentives and support for significantly enhancing availability of skilled

manpower, including re-skilling, in the ESDM sector

- Promoting research, innovation and support to industry for green processes and sustainable e-Waste management, including inter-alia facilitation of citizen engagement programmes for safe disposal of e-Waste in an environment friendly manner, development of e-Waste recycling industry and adoption of best practices in e-Waste management
- Emphasis on Cyber Security and promoting trusted electronics value chain initiatives to improve India's national cyber security profile
- Providing special support for developing core competencies in the following sub-sectors of Electronics:
 - o Fabless Chip Design Industry
 - o Medical Electronic Devices Industry
 - o Automotive Electronics Industry and Power Electronics for Mobility
 - o Strategic Electronics Industry
- Creation of Sovereign Patent Fund (SPF) to promote the development and acquisition of IPs in ESDM sector

The following new policy initiatives are being undertaken under the aegis of NPE 2019, which are at proposal stage:

- **Interest Subvention Scheme:** The scheme proposes to provide interest subsidy of 4% -6% on the loans upto Rs. 1,000 crore for plant and machinery to offset the disability of finance cost faced by the manufacturers in India due to higher interest rate compared to the interest rate on loans in other competing countries. -

- **Credit Guarantee Fund Scheme:** This scheme proposes to create a fund to provide default guarantee to the banks upto 70% of the loan on plant and machinery for loans up-to Rs.100 crore. This will eliminate the need for small and new investors to provide third party collateral currently being demanded by banks for giving such loans.
- **Electronics Manufacturing Clusters 2.0:** EMC 2.0 proposes to provide support for creating infrastructure and common facilities, including specialized facilities, which will be provided in collaboration with State Governments for a group of industries, who are part of a supply chain of a product, so that entire eco-system of a product can be created at a location. This will improve competitiveness and help exports, thereby making India a hub for global electronics manufacturing.
- **Scheme for promotion of manufacturing of Electronic Components and Semiconductors (SPECS):** The manufacturing of electronic components and Semiconductors is capital intensive and must deal with constantly changing technology. Components are at the heart of electronic products and constitute a significant part of the total value of Bill of Material (BOM). Therefore, a Scheme is being worked out for providing financial incentive of 25% of CapEx for the identified list of electronics goods, mainly covering electronic components, semiconductor/ display FABs, ATMP, specialized sub-assemblies and capital goods for manufacture of these goods.

- **Production Linked Incentive Scheme (PLI) for Large Scale Electronics Manufacturing:**

The scheme aims at providing production linked incentive of 5 - 8% on incremental sales of specific categories of electronics goods manufactured in India viz., Mobile handsets, ATMP/ IC Packaging and Specified components.

3.9 Centre of Excellence in Electronics and ICT Application

3.9.1 National Centre of Excellence for Large Area Flexible Electronics

National Centre of Excellence for Large Area Flexible Electronics (NCFlexE) is being established at IIT-Kanpur with a project cost of Rs. 132.99 crore to establish a research programme to engage in leading edge research in large area flexible electronics and build strategic academic collaborations to address requirements through joint technology developments, to realize home grown technologies for manufacturing. The project is envisaged to target One Spin-off commercial venture and establish standards for electronics products in the field of Flexible electronics. The Centre is working on 10 nos. of joint technology development projects, which are in various stages of developments. Their developments fall in the area of OLEDs, TFTs, Flexible Photovoltaic (FlexPV), Smart Tags, Sensors, anti counterfeiting for medicine package; conductive inks etc. two technologies/solutions have been transferred to industry to take the product at manufacturing level:

- Smart Tag, an unclonable tag that can be read by a phone for Unambiguous authentication based on the security at mathematical level
- Conductive Carbon paint, for Do it yourself (DIY) Application

The other projects are at various stages of developments/translation levels and trials.

3.9.2 National Centre of Excellence in Technology for Internal Security (NCETIS)

National Centre of Excellence in Technology for Internal Security (NCETIS) is being established at IIT Bombay at a cost of Rs. 83.89 crore to address the challenges of homeland security and to develop state-of-the-art technologies which are vital for the national security agencies for providing rescue and relief operations with the indigenously developed technologies/ products. The NCETIS centre is single point interface in mobilizing research and the manufacturing industry to address technology gaps encountered in the strategic sector of homeland security. The NCETIS made progress in initiating several innovation/R & D joint technology projects to address the strategic challenges of internal security. Presently, the Centre is working on 19 joint technology development projects, which are at various stages of developments viz; Video Analytics in Internal Security, Remotely Operated Vehicle (ROV), Ground Penetrating Radar, Social Media Analytics Tool, Identification of Friend and Foe (IFF), Canine Mounted Video Surveillance System, Handheld Explosive Detector (BEAGLE-Z), Development of a Block Cipher etc. Four technologies/solutions have been transferred to industry to take the product at manufacturing level:

- Fully Automatic Handheld Explosive Detector (Beagle Z)
- Unmanned Portable Remotely operated All-Terrain Vehicle (Medium Duty, Light Duty, Backpack)
- Social Media Analytics Tool
- Video Analytics Tool

The other technologies under collaborative development for homeland security are in various stages of developments/translation levels and trials.

3.9.3 Next Generation AMOLED Displays, OLED Lighting and OPV Products

The project for setting up of Next Generation AMOLED Displays, OLED Lighting and OPV Products at IIT-Madras has been approved in July, 2018 at a cost of Rs. 32.13 crore including Government Grant-in-aid of Rs. 25.18 crore. The objective of the said project is to collaborate with stakeholders to develop next-generation, state-of-the-art, high-volume and cost effective electronic components based on organic devices to address requirements through joint technology developments, to realize indigenous technologies for manufacturing. This Project will develop prototypes on AMOLED displays for mobile products, OLED lighting panels, and lightweight OPV devices by utilizing high speed deposition technique to achieve

“economies of speed” for micro-factories. The project is currently under implementation phase.

3.10 Marketing and Promotions to Attract Investment in ESDM Sector

3.10.1 State & National Level Workshops

Under the aegis of NPE-2019, MeitY has engaged with the domestic and foreign stakeholders of the Electronics System Design and Manufacturing (ESDM) sector, State Governments, International Government bodies etc. through various levels of “Below The Line” (BTL) events such as conferences, seminars and workshops.

International Conferences

Taiwan Expo: A delegation from MeitY participated in the inaugural session of 2nd edition of Taiwan Expo held on 16th May, 2019 at New Delhi. Taiwan Expo registered participation of more than 110 exhibitors from the diversified sectors showcasing



products on ICT, EV, Green Products, Medical Devices Agriculture, Food, Textile etc.

China-India Mobile Handset Industry Resource Matching Meeting: A delegation from MeitY participated in the China-India Mobile Handset Industry Resource Matching Meeting held on July 25, 2019 at Greater Noida. Mr. S.K Marwaha, Scientist ‘G’ delivered a speech on “Political and Business Environment for Made in India”. The event registered participation of nearly 150 Mobile Ecosystem companies (Indian & Chinese) along with key industry associations.

Joint Training Programme in the field of ESDM and IT: A MoU on “Joint Training Programme in the field of ESDM and IT” has been signed between National Institute of Electronics and Information Technology(NIELIT), India and Institute for Information Industry (III), Taiwan on 17th October 2019 during India-Taiwan Industrial Collaboration Summit at Taipei, Taiwan. The MoU will enhance

cooperation in training and skill development in the field of Electronics and Information Technology, through the exchange of institutional experience, training and skill development.

MEIT Round table: A roundtable meeting under the chairmanship of Hon’ble Minister of Electronics and IT was organised with the key leaders of Electronics Industry on 16.09.2019 at New Delhi. The key objective of meeting was to recognize the key challenges being faced by the Industry, opportunities and expectations of the industry from the Government. Companies from different verticals of electronics sector such as mobile handsets, consumer electronics, strategic electronics, medical devices, Information Technology, electronic manufacturing services, electronic components, telecom and LED lighting were invited. Some of the key industry leaders who participated in round table were from Apple, Samsung, Vivo, Oppo, Lava, Qualcomm, Dell, HP, Philips, Bosch, Flextronics, Foxconn, Nokia, Panasonic, TDK, AMD, Delta,



Salcomp, Sterlite Technologies and Nidec, among others.

44th ELCINA Annual Awards: The 44th ELCINA Annual Awards 2018-19 was held on 25th September, 2019 at Greater Noida. Shri Ajay Sawhney, Secretary, MeitY and Shri Sanjay Kumar Rakesh, Joint Secretary, MeitY attended the event and presented awards to the winners.

3.10.2 Visits to Attract Investment in ESDM Sector

TAITRONICS 2019: A Government-Industry Delegation led by Shri Ajay Sawhney, Secretary, (MeitY) visited Taiwan during 15-18 October, 2019 for promotion of Investment in ESDM sector and participation in TAITRONICS 2019 and had various one-to-one meetings with key Taiwanese ESDM companies such as Sercomm, Foxlink, Foxconn, Nanya Plastics, Passive System Alliance (PSA), Wistron, Tripod and Delta Electronics. During the visit, the delegation also participated in 3rd India-Taiwan Collaboration Summit, wherein a presentation on enabling policies and investment opportunities in electronics manufacturing in India was given by Shri S.K. Marwaha, Scientist 'G', MeitY.

3.10.3 Handholding and Facilitation for Investors to Attract Investment in ESDM Sector

Investment Facilitation/Promotion Cell has been established in MeitY to handhold and help investors during their various stages of transition. To expedite and facilitate the proposals of investment from various companies; the investment promotion Cell facilitate interactions with State Governments and other agencies of Government of India.

Help-Desk for Taiwan, Japan and Israel is also present in the Ministry.

3.10.4 Social Media Participation

In the global scenario of cyberspace prominence, social media has emerged as an increasingly preferred media by the decision makers and

general public at large to communicate, interact and engage with each other. Taking view of this emerging reality, social media forms an important media vehicle for Electronics India to engage with the stakeholders.

Electronics India operates in a space which is a symbiosis of electronics and information technology, with all the stake-holders making an extensive use of the new forms of communication and media tools, especially the Social Media. As a matter of fact, the Social Media has been developed out of the industry that Electronics India focuses to nurture and grow.

Hence, given its characteristics to potentially give “voice to all”, immediate outreach and 24x7 engagement, Social Media offered a unique opportunity to Electronics India to engage with various ESDM stakeholders in real time to make policy making more stakeholder centric.

In order to tap digital media platform, MeitY is handling Twitter account “Electronics_GoI”, which is being preferred by all the ESDM stakeholders and engagement medium by the people with MeitY

3.10.5 B2B Portal

In order to attract investment into ESDM sector and create opportunities to introduce latest technologies to Indian industry a need was felt of a common platform where the technology providers, technology seekers and JV seekers could come together to explore possibilities of tie up. In its endeavour to encourage development of Electronics System Design and Manufacturing (ESDM) ecosystem in India, MeitY created a platform on its website which helps various technology players to explore potential partners for technology transfer and joint ventures for electronics manufacturing in India.

Till now the platform has been utilized by 41 multinational and domestic companies to display their intent to seek suitable partners. Link for the Portal is: “<http://www.MeitY.gov.in/esdm>.”

Chapter – 4

Make in India: Software and Services



4.1 Global Perspective

The Indian Information Technology/Information Technology enabled Services (IT/ITeS) industry has contributed immensely in positioning the country as a preferred investment destination amongst global investors and creating huge job opportunities in India, as well as in the USA, Europe and other parts of the world. The industry has differentiated itself in the global competition on account of consistent service and guaranteed results and has also helped forge strong bilateral ties with nations.

The Indian IT-Business Process Management (IT-BPM) industry has played a key role in India's economic growth over the last ten years. Over the last decade, the industry has grown over five fold in revenue terms, thus contributing a substantial share to India's GDP. More importantly, the industry has led the economic transformation of the country and altered the perception of India in the global economy.

The global sourcing market continues to grow at a higher pace compared to the IT-BPM industry. The global IT and ITeS market (excluding hardware) expected to reach USD 1.4 trillion in 2018-19 and the global sourcing market reached USD 194-198 billion. India continued as the world's top sourcing destination with a share of about 55 percent. In FY 2017-18, Indian IT and ITeS companies set up over 271 new global delivery centres around the world. IT-industry is fueling the growth of startups in India with the presence of around 7,000-7,200 start-ups making India the world 2nd largest start-up ecosystem. Many of these are working on very niche technologies – AI, blockchain, robotics, analytics, automation, cyber-security etc. These start-ups, coupled with new and emerging technologies, are enhancing the digital economy of the country and are creating IT and electronics led new job opportunities in both traditional as well as new sectors of the economy, such as, transport, health, power, agriculture, and tourism.

As per NASSCOM's (National Association of Software and Services Companies) estimates for FY 2018-19, industry revenue (excluding hardware) would touch USD 164 billion, up from USD 151 billion in FY 2017-18, showing a growth of over 8%. In addition, e-commerce would fetch over USD 43 billion, assuming the existing 11% Y-o-Y (Year on Year) growth pattern. India's IT-BPM industry revenue is expected to reach USD 181 billion. The industry employs more than 4.1 million people with an addition of about 1,72,000 people (approx) in FY 2018-19. IT-BPM exports from India are expected to reach USD 136 billion during FY 2018-19, with over 8% growth.

Driven by the increased digital adoption and growing Internet Economy, India's domestic IT-BPM (excluding hardware) is expected to reach USD 28 billion at 8% growth in FY 2018-19. India has the 2nd largest Internet user base after China with over 432 million subscribers, with more than 300 million smartphone users.

The Government has identified Information Technology (IT) and IT enabled Services (ITeS) as one of 12 champion service sectors for realizing their full potential. Government of India has also undertaken a consultative approach with the industry associations and industry members to discuss measures to improve the overall state of the IT industry and key challenges being faced towards realizing the USD 1 trillion digital economy by 2022. Goods and Services Tax (GST) is one of the biggest tax reforms undertaken by the country. Other efforts include measures to streamline the tax regimes, streamlining procedures and improving the overall ease of doing business. Government initiatives, such as, Start-up India, Digital India and Smart Cities are expected to give boost to e-Governance and m-Governance related business activities. There is significant push from the Government to go digital and adoption of digital payments. Efforts are also being made to diversify

and increase presence in other markets, such as, Europe (besides UK which is a mature market), Africa, South America, Israel, Australia, China and Japan.

4.2 BPM Industry Promotion

MeitY is working towards the vision of Digital Inclusion and to create new opportunities in the digital economy India BPO Promotion Scheme (IBPS) and North East BPO Promotion Scheme (NEBPS) have been initiated in 2015 under IT for Jobs pillar of Digital India programme. These schemes aim to incentivise setting up of BPO/ ITeS operations across the country, particularly in small towns/cities, to create employment opportunities and promote dispersal of the industry for balanced regional growth. A total of 48,300 seats under IBPS and 5000 seats under NEBPS have been planned. The duration of IBPS was up to 31.03.2019 while NEBPS is up to March 2020. Under IBPS Seat distribution to States and UTs was based on population as per 2011 Census. The outlay of the Scheme is ₹ 493 crore (IBPS) and ₹ 50 crore (NEBPS).

Salient Features

- **Financial Support:** These schemes provide financial support up to ₹ 1 lakh per seat in the form of Viability Gap Funding (VGF) towards Capital and Operational expenses for a period of 3 years.
- **Special Incentives:** These schemes also provide special incentive for promoting local entrepreneur, employment to women and physically challenged persons, setting up operations at other than State capital, and providing employment beyond target.
- **Effective Implementation:** To ensure transparency and smooth implementation of these schemes processes, such as, bidding, reporting, monitoring and disbursement are

made completely online and done through dedicated Web Portal www.ibps.stpi.in and www.nebps.stpi.in which are one stop web portal to know bidding details, status, news, alerts and other related information regarding India BPO Promotion Scheme (IBPS) and North East BPO Promotion Scheme (NEBPS). These web portals also provide special login for bidders to submit progress report, raise disbursement requests related to financial support and special incentives etc.

- **Focus on Employment generation through IT/ITES:** The disbursement of financial support under these schemes is directly linked with the outcome i.e. employment generation.

Location of BPO/ITeS Units under IBPS and NEBPS

Some of the Operational Units are at:

Patna, Muzaffarpur, Raipur, Shimla, Sagar, Bhubaneswar, Cuttack, Jaleswar, Kottakuppam, Bhaderwah, Budgam, Jammu, Sopore, Srinagar, Aurangabad, Bhiwandi, Sangli, Wardha, Bareilly, Kanpur, Varanasi, Guwahati, Jorhat, Kohima, Imphal, Madurai, Mayiladuthurai, Tiruchirappalli, Tiruppattur, Vellore, KarimNagar, Tirupati, Guntupalli, Rajamudry.

Operational Units under BPO Promotion Scheme

Overall Status of BPO Promotion Schemes	
Total Seats in IBPS and NEBPS	52,300
Total Seats – Allocated	52,972
Total Seats – Operation Started	48,759
Total Units Approved	297
Total Units – Operation Started	259
Tier-II/III Cities covered	119
Employment Generated	33,987

Impact

Dispersal of Industry: Growth of IT/ITES sector in India has traditionally remained confined to a few select urban clusters. BPO Promotion Schemes are facilitating in expanding the base of IT/ITeS industry and creation of employment opportunities beyond metros. Under IBPS and NEBPS, 259 units have set up at over 100 locations distributed across 28 States/ UTs during the year 2019-20.

Journey towards Digital India through bridging of the digital divide: The NEBPS and IBPS were launched in 2015 and 2016 respectively. As the location of BPO/ITeS operations is client driven, and the metro cities were excluded from these schemes, the industry response to these schemes was not very encouraging at the beginning but gained momentum over the period of time. The BPO/ITeS units in Tier-II/III cities are changing the digital profile of the nation by creating job opportunities in ITeS sector and developing the ecosystem for the dispersal of IT industry.

- **Empowerment and inclusion of marginalized groups of the society:** The schemes encourage employment to women and differently abled persons. Under these schemes, special incentives have been provided to the units encouraging employment to women, and specially abled persons. Out of the total employment provided by BPO/ITeS units under these schemes, around one third are women.
- **Job opportunities near home with the ease of living:** The BPO/ITeS units starting in Tier-II/III locations are providing job opportunities to the youth near their home which would reduce the migration to metros and lower the attrition rate. The BPOs in small towns and cities are providing services in local languages, which would create employment opportunities for the local youth and services provided in local languages that results in better customer satisfaction.

North East BPO Promotion Scheme (NEBPS)

Government has also launched North East BPO Promotion Scheme (NEBPS), under Digital India Programme, to incentivize setting up of 5,000 seats BPO/ITeS Operations in North East Region (NER), create of employment opportunities for the youth and growth of IT-ITeS Industry. NEBPS provides similar financial support as IBPS with outlay of ₹ 50 crore. Till now, 16 companies have been selected to set up 21 units for a total of 1675 seats BPO/ITeS operations spread across the 6 States of NER, namely, Assam, Nagaland, Meghalaya, Manipur, Arunachal Pradesh and Tripura. Out of these, 14 units have started operations for a total of 1,275 seats with initial employment to over 650 persons. Further details of the scheme are available at <https://nebps.stpi.in>.

4.3 National Policy on Software Products

The Union Cabinet, chaired by the Hon'ble Prime Minister Shri Narendra Modi approved the National Policy on Software Products 2019 on February 28, 2019 to develop India as a Software Product Nation. The policy aims to develop India as the global software product hub, driven by innovation, improved commercialization, sustainable Intellectual property (IP), promoting technology start-ups and specialized skill sets. Further, the policy aims to align with other Government initiatives such as Start-up India, Make in India and Digital India, Skill India etc. so as to create Indian software products industry of USD 70-80 billion with direct & indirect employment of 3.5 million by 2025.

The salient features of the policy are as follows:

- To promote the creation of a sustainable Indian software product industry, driven by intellectual property (IP), leading to a ten-fold increase in India share of the Global Software product market by 2025.
- To nurture 10,000 technology startups in software product industry, including 1,000

such technology startups in Tier-II and Tier-III towns and cities and generating direct and in-direct employment for 3.5 million people by 2025.

- To create a talent pool for software product industry through (i) up-skilling of 1,000,000 IT professionals, (ii) motivating 100,000 school and college students and (iii) generating 10,000 specialized professionals that can provide leadership.
- To build a cluster-based innovation driven ecosystem by developing 20 sectoral and strategically located software product development clusters having integrated ICT infrastructure, marketing, incubation, R&D/testbeds and mentoring support.
- In order to evolve and monitor schemes & programmes for the implementation of this policy, National Software Products Mission will be set up with participation from Government, academia and industry.

4.3.1 Indian Software Product Registry

To promote Software Product ecosystem, an Indian Software Product Registry (ISPR) has been created and launched during MeitY Start-up Summit on 21st October, 2019 in New Delhi (www.ispr.gov.in). This registry would be a single window portal for collation of Indian Software Product Industry database. The registry will act as a common pool of Indian Software Products thereby providing a trusted trade environment in various emerging software products. This will also bring the visibility at national and international level to all the scattered efforts going on in the country in the development of software products onto a single platform. The proposed registry will serve the following purpose:

- Provide database/ catalogue for all the Software Products Companies and the software products developed in India with any analytics around what kind of domains, sectors, geo-

regions are currently being served; how many new Products/ Startups are getting created on a monthly/ quarterly basis etc.

- List products category wise, industry wise, technology wise, type of openness (proprietary or open source), intended audience (B2B or B2C or B2G), product stage (alpha, beta, production), licensing type etc.;
- Detailed description of each product along with features, imageries, team, company information etc.;
- Serving as a gateway to the Indian Software Product Company (ISPC) with exposures to millions of global players who are seeking great partnership with the local software product industry;
- Core Identity base for the ISPR's to be ported to Government e-Marketplace (GeM) for enhanced market access;
- Facilitation of Indian Software Product Industry for providing fiscal incentives, if any, at a later stage;
- Statistics on number of products and companies registered, information about the company such as company profile, number of employees, Annual turnover, export and domestic revenue, location, company type etc. As of now, 49 Companies and 59 products have been registered on ISPR.



1st meeting of the National Software Product Mission

- **National Software Products Mission** was Launched to **evolve and monitor schemes, programmes and strategy** for the implementation of National Policy on Software Products

4.3.2 MeitY–NASSCOM Startup Women Entrepreneur Award 2019 for Software Products

In order to recognise wonderful achievements of the women entrepreneurs in Software Product sector, MeitY – NASSCOM Startup Women Entrepreneur Award 2019 for Software Products was concluded with following aims and objective:

Aims & Objective:

- To recognize and cultivate the entrepreneurial spirit in women and inspire the next generation of women to lead the Indian digital era so as to serve as guiding role models.
- To encourage promising Entrepreneurs who not only contribute to the nation economy but also the social community.
- These entrepreneurs will serve to provide leadership and also as guiding examples for emerging and young or future entrepreneurs.

Seven Women entrepreneurs have been awarded by Rs. 2 Lakhs each in 6 categories by Hon'ble MEIT, Shri Ravi Shankar Prasad during MeitY Startup Summit on October 21, 2019 in New Delhi.

4.4 Software Technology Parks Scheme

For the promotion of Software exports from the country, Software Technology Parks of India(STPI) was set up in 1991 as an Autonomous Society under the Ministry of Electronics and Information Technology. STPI acts as 'single-window' in providing services to the software exporters. STPI has set-up a total of 59 STPI operational centres/ Sub-centres across the country, out of which 51 centres are in Tier II and Tier III cities.

The STP scheme allows software companies to set up operations in convenient and inexpensive locations and plan their investment and growth driven by business needs. There are many benefits under STP scheme like duty free import of capital goods which are also IGST exempted, capital goods purchased from DTA are entitled for refund of GST, 100% FDI is permitted, Sales in the DTA is permissible, 100% depreciation on capital goods over a period of 5 years etc.

4.5 Domain Specific Centres of Excellence Across the Country by STPI

To ensure India builds leadership in the emerging sectors of IoT, Block Chain, FinTech, Artificial Intelligence, Augmented & Virtual Reality, Medical Electronics, Health Informatics, Gaming & Animation, Machine Learning, Data Science & Analytics, Cyber Security, Chip Designing, ESDM etc. and to build next wave of budding entrepreneurs, Honorable Minister of Electronics & IT announced setting-up of domain centric “Centers of Excellence” (CoEs) by STPI in collaborative manner across India. The CoEs aim at providing comprehensive structural & fundamental support including lab & incubation, training, mentoring, hand-holding, funding etc. through a joint collaborative effort of Govt of India, State Govt, Industry, Academia, Domain & Technology experts etc. Accordingly, STPI is currently setting-up around 18 domain-specific CoEs in collaboration with suitable partners in various parts of country and more CoEs are in pipeline.

VR/AR CoE at Bhubaneswar, Fin Tech CoE (“FinBlue”) at Chennai, IoT Open Lab CoE at Bengaluru, AI/Data Analytics / AVG / IoT CoE (“Neuron”) at Mohali and ACES CoE (“Motion”) at Pune have commenced activities and are scouting for start-ups for incubation via a formal “Call for Application” process & Open Challenge Program. ESDM Incubation CoE at Bhubaneswar (“Electropreneur Park”) has been launched in

December 2019. Medi-Tech CoE at Lucknow is in the process of completing necessary formalities with stakeholders and shall kickstart operations shortly. Block Chain CoE at Gurugram, Gaming/VFX/CV/AI CoE at Hyderabad, Smart AgriCoE at Patna-Motihari and 8 CoE-SIZs in each of the 8 NE capital cities are in last stages of approval process & stakeholder onboarding.

4.6 International Cooperation Division (ICD)

With the Government’s outlook on digital diplomacy, digital economy and launch of digital india programme, MeitY has synergized its efforts to expand IT/ITeS sector globally including diversification to geographies, domain expertise, high skill work forces to enhance business opportunities. Efforts have been made to evolve strategic cooperation with potential foreign partners in emerging and frontier areas of information and communication technology under bilateral and multilateral framework of cooperation. The Ministry regularly engages with various Governments, including academic and industries bodies for forging partnerships for mutual progress and also provide an opportunity for sharing of knowledge and experience. The International Cooperation Division has been involved in the following tasks:

- Aligning foreign collaboration activities with India’s ‘Digital India Programme’ and ‘Make in India’ initiatives of the Government of India.
- Strengthening India’s position on multilateral fora for different issues like e-commerce, digitalisation, digital divide, digital government, digital infrastructure and gender divide etc.
- Creating a conducive environment for international cooperation to help industries to cooperate with the industries of other countries.
- Fostering, encouraging and promoting research and development in the application of information technology related facilities.

- Coordinating technical and policy issues with international bodies/institutions like G20, RCEP, UN and its associated organisations ((UNESCO, UNCTAD, UNDP, ECOSOC, ESCAP etc.), ASEAN, SCO, BRICS, SAARC, WSIS, World Bank, WTO, ADB, World Economic Forum (WEF), to safeguard India's interest.
- Initiating joint projects like IT institutes, software parks, programmes for joint R&D and facilitating IT advisers etc.
- Showcasing India's ICT strength across the globe by organizing, sponsoring and participating in trade fairs, symposiums, exhibitions etc.

The International Cooperation Division of this Ministry has been pursuing the above objectives through Memorandum of Understandings (MoUs), Joint Working Groups (JWG) meetings, Multilateral deliberations/ negotiations, Projects in other geographies/countries, participating in major International events to showcase India's strength and enhance business opportunity for Indian IT/ Software Industry. Also, issues faced w.r.t India's IT exports and mobility of Indian IT professionals have been handled at various bilateral and international forums from time to time.

Multilateral Cooperation

In order to protect India's interest and promote India's Digitalisation story on global platforms, MeitY actively participated in various multilateral meetings including G20, BRICS, Regional Cooperation on Economic Partnership (RCEP), Shanghai Cooperation Organization (SCO).

Under the G20 Japanese Presidency, the Ministry negotiated various ICT issues in G20 Digital Economy Task Force (DETF) meetings and presented India's position. A Ministerial Statement on Trade and Digital Economy was adopted during the G20 Digital Minister's meeting held in June,

2019 to strengthen cooperation on Society 5.0, Data flow, Governance Innovation, Human Centric AI, AI Principles, Digital Security SDGs & Inclusion, role of Data for development.

The Ministry participated in the 3rd meeting of the BRICS Working Group on Information and Communication and High Performance Computing in May, 2019 under the Brazilian Presidency. India presented the various ICT activities being undertaken by the Ministry and its impact on the citizens of the country which was well appreciated by the BRICS members.

India was invited by the Government of France for the G7 Digital Ministerial meeting held on April 14-26, 2019 at Paris and Secretary, MeitY led the Indian delegation comprising senior officials of MeitY and presented India's position on the three key issues initiated by the French Presidency, i.e. Online Harms, Human Centric AI and Innovation & Trust in Data-Driven technologies. India also welcomed the constitution of the proposed International Panel on AI (IPAI) and extended support to the draft version of the Christchurch Call which was to be released by an assembly of world leaders including those from France, New Zealand etc towards greater accountability from Social Media platforms in issues such as containing live streaming and to reduce the usage of such platforms by terrorist elements. A Chair's Summary was adopted on Strengthening international cooperation on a human centric artificial intelligence and its use in reducing inequalities, fight online harms and Building trust in data-driven technologies and digital infrastructures together. The participants recognized that efforts on this issue will continue in many different international and multilateral fora, including at the G7.

The Ministry attended 7th meeting of the Special Working Group on Modern Information and Telecommunication Technologies under Shanghai Cooperation Organization (SCO) held in October

2019 at Bishkek, Kyrgustan. The meeting discussed the Plan for implementation of the Cooperation Concept of the SCO Member States in digitalisation and ICT.

4.7 Cooperation through Bilateral Interaction

A Joint Working Group (JWGs) meeting with Kyrgyzstan was held to further ICT and IT/ITeS trade and also to forge cooperation in the area of innovation and R&D. A concrete outcome based action plan and specific initiatives including projects were identified for furthering such cooperation. Also, various high level delegation visited India which includes ministerial level from Uzbekistan and Zimbabwe.

A high level Chinese delegation lead by H.E. Mr. Huang Chuping, Executive Vice Governor of Hubei Province, People's Republic of China visited MeitY on April 15, 2019. Both sides discussed on the development of IT-ITeS industry and the current situation of software industry and hardware Industry of the two countries. The opportunities available in the area of Electronics System Design and Manufacturing (ESDM) sector, Emerging technologies etc. have also been discussed in detail for future cooperation between India and China.

A Meeting between India and EU held on 9th May, 2019 under the chairmanship of Shri Pankaj Kumar, Additional Secretary, MeitY from India side and Mr. Roberto Viola, Director General, DG-CONNECT, EU side to discuss the latest developments in the area of Information and Communication Technologies (ICT), to inform about the digital policies of the European Union and to explore ways to deepen cooperation between India and the European Union in ICT sector. The agenda of the meeting included Digital for Development, Data Governance and Research & Innovation.

A high level Moroccan delegation led by H.E. Mr. Mohammed Rherras, Hon'ble Secretary of State to the Minister of National Education, Vocational

Training, Higher Education and Scientific Research, in charge of Vocational Training, Government of the Kingdom of Morocco visited MeitY on May 24, 2019. Both sides discussed on the way forward mechanism for fostering cooperation in areas of mutual interest such as e-Governance, HRD and Capacity building, IT-ITeS trade promotion etc Capacity so as to focus on innovation in ICT for realizing the benefits of Digital Economy.

A high level Chinese delegation led by H.E. Mr. Li Youxiang, Deputy Mayor, Wuhan Municipal People's Government, People's Republic of China visited MeitY on June 07, 2019. Both sides discussed on the development of IT-ITeS industry and the current situation of software industry and hardware Industry of the two countries. The opportunities available in the area of Electronics System Design and Manufacturing (ESDM) sector, Emerging technologies etc have also been discussed in detailed for future cooperation between India and China.

An Uzbekistan delegation lead by Deputy Governor of Syrdarya region, Mr. Avaz Khodjiev visited MeitY on 11th July, 2019 to discuss promotion of investments and trade in Syrdarya region.

A Video Conferencing meeting with Vietnam as a follow up to the India-Vietnam JWG was held on Wednesday 14th August, 2019 from MeitY. The meeting was Co-Chaired by Mr. Rakesh Maheshwari, Group Coordinator of MeitY from the Indian side. The meeting agenda was discussed on e-Governance and Data Governance, open data of e-Government example of data.gov.in, NKN etc.

An MoU in the Field of e-Governance and Emerging Digital Technologies between MeitY of the Republic of India & Ministry of Economic Affairs and Communications of The Republic of Estonia was signed on 21st August, 2019 in Estonia. As a follow up to the Ministerial dialogue this MOU could enhance cooperation not only to e-Governance,

also boost cooperation in the Emerging Digital Technologies especially, artificial intelligence, machine learning, data analytics, robotics, visual data processing, virtual reality etc.

The 1st JWG meeting between India and Belgium under the signed MOU on IT&E and B2B & G2B meetings with Belgium to enhance cooperation activities, IT business, Cyber security with Belgium and to resolve the issues was held during 10-11 September 2019 in Brussels. The agenda of the meeting covered discussion and Exchange best practices on Digital India & Digital Belgium, emerging technologies, cyber security and on establish linkage of both industries.

The 16th India-EU JWG meeting in Brussels was held on 11-12 September 2019 in Brussels. The EU JWG agenda was listed with several important issues like, ITeS Business, Data Governance, Cyber security/adequacy, emerging technologies like AI, HPC, M2M, IoT etc. along with Telecom issues like 5G, Spectrum, Standards, Encryption etc. to enhance regular cooperation activities with EU member countries under the Action 2020 plan with EU.

Under the framework of 6th India-China Strategic Economic Dialogue, the Working Group on High-Tech was held on September 7th, 2019 in New Delhi. The meeting was co-chaired by Joint Secretary, Shri Sanjay Goel, Ministry of Electronics and Information Technology from the Indian side and Mr. Wu Hao, Director General, Department of Innovation and High-Tech Development, National Development and Reform Commission (NDRC) from the Chinese side. In the Working Group meeting, both sides exchanged views on regulatory procedure of ease of doing business, development of artificial intelligence, high-tech manufacturing, and next-generation mobile communications of both countries; shared views on technological innovation, industrial situation, and mechanism for further strengthening cooperation. In addition,

both sides exchanged views on India-China digital partnerships, data governance and related industry policy.

After a three years gap, the India-US ICT Dialogue (WG) was held on 1st October 2019 in New Delhi comprising G2B and G2G sessions. During G2B session both sides discussed the issues and opportunities in emerging technologies, Global value chain, Data & Digital Economy including job creation and skills gap. During the G2G session both sides discussed on Mobility, H-1B & H-4 visas, & Other Related Issues for the IT Industry in USA, and level playing field for industry, on Privacy and data protection, Platform Economy related issues, Collaboration in Emerging Technologies and digital transformation, Electronic Manufacturing, Cyber Security and Cooperation in International Fora, including the ITU, G20, G7.

A meeting between Hon'ble Minister of Electronics and Information Technology and U.S. Senator Maggie Hassan was held on 11th October, 2019 in MeitY. During the courtesy meeting, Hon'ble MEIT apprised her that the Strategic Partnership with the U.S. is a priority for us, and we attach great importance to this relationship. Also, Hon'ble MEIT informed about India's achievements in Digital sector and willingness to cooperation with US in this sector.

A Japanese study tour to India was organized by JETRO under METI: Ministry of Economy, Trade and Industry, Japanese Government to study further Digital India, India Stack, and related programmes. The participants include several largest Japanese IT companies such as NTT Data Corporation, ITOCHU Techno-Solutions Co., NEC Corporation, Fujitsu Limited, Oki Electric Industry Co., Ltd. etc. In this regard, a meeting cum demonstration under the Chairmanship of Shri Rajiv Kumar, Joint Secretary held on 5th November 2019 in MeitY to demonstrate and discuss on the Digital India products, India Stack concepts to find out the possible model of development in India-Japan Digital Partnership.

A meeting between Hon'ble MOS (E&IT) Shri Sanjay Dhotre and a 12 member Japanese delegation of international Friendship Exchange Council (FEC) headed by Vice Chairperson, Mr. Watanabe, and former Ambassador Hirabayashi was held on 5th November 2019 in MeitY. The purpose of the meeting was to discuss the current status of Information Technology in India and expectations of Japan. During the meeting, Hon'ble MoS(E&IT) highlighted Digital India program and its benefits to the large Indian population, also appreciated the progress made on India-Japan Digital Partnership.

A Latvian ICT delegation including Mr. Juris Štālmeistars, Director General of the Economic Relations, Trade and Development Cooperation Directorate of the Ministry of Foreign Affairs of Latvia, and representatives of the leading Latvian telecommunications operator "Latvijas Mobilais telefons" (LMT), visited India on their first exploration visit to India. Latvia is keen to explore cooperation opportunities with India in the ICT sector. In this regard, a meeting cum demonstration under the Chairmanship of Shri Rajiv Kumar, Joint Secretary was held on 21st November, 2019 in MeitY, to demonstrate and discuss on the Digital India products, concepts to find out the possible model of development in India-Latvia Digital Partnership.

A meeting between Shri Ajay Sawhney, Secretary, MeitY and Mr. Shigehiro Tanaka, Vice-Minister for International Affairs, Ministry of Economy, Trade and Industry (METI), Government of Japan was held on 22nd November, 2019 at MeitY to discuss progress on India-Japan Digital Partnership to extend the cooperation. Both sides expressed satisfaction with ongoing progress made on India-Japan Digital Partnership and confident to enhance the cooperation activities.

A meeting between Shri Ajay Sawhney, Secretary, MeitY and Mr. Jari Gustafsson, Permanent

Secretary, Finland held on 22nd November 2019 at MeitY, followed by the signing ceremony of the Joint Declaration of Intent (JDI) on Cooperation in the field of Digitalisation between India and Finland. Finland and India have traditionally enjoyed warm and friendly relations. Finland sees India as a market for its products and a favourable investment destination for its high technology industries. India views Finland as an important member of the EU and a repository of modern technology. Finland has brought SMS, 5G, and the Linux operating system to the world. All this is enabled by active co-operation between the public and private sectors, combined with an active start-up scene and innovative testbeds. Finland has an environment constantly produces new technological innovations and brilliant end-user applications. The purpose of the meeting was to discuss ICT/Digital collaboration and opportunities between Finland and India. The scope in the JDI is to emphasize G2G and B2B cooperation with Finland and pivoting to the Nordic region. We have already signed an MOU in cyber security with Finland.

The Global Exhibition on Services (GES 2019) organized by the Ministry of Commerce & Industry, Government of India was held from 26-28 November, 2019 in Bengaluru, Karnataka. GES is an Annual event for service trade promotion and also explore the possibility of enhancing cooperation between all concerned stakeholders and tap the potential for services' export. MeitY participated in GES 2019 with the theme of 'New India-Digital India' to showcase broad spectrum of MeitY's Activities towards harnessing Public Digital Platforms and startup ecosystem in the country. The MeitY pavilion was visited by Hon'ble Minister for Commerce & Industry, Shri Piyush Goyal and was appreciated showcasing of India's Digital Journey and overwhelmingly encouraged the participated Start-ups in MeitY's Pavilion with their products and services.

4.7.1 Software Products as a Tool for Economic Growth

For the holistic growth of the IT industry and to move it up the value chain, a vibrant software product sector is essential. Hence the need for a comprehensive ecosystem to support a sector primarily comprising of young entrepreneurs is required, that can synergize the efforts of the Government and Industry to create a robust Software Product Industry, which enables the germinating ground for large number of Software product startups, promotes development of an ecosystem encouraging R&D and innovation, IT/ITeS sector, opens up multitude of opportunities of access to capital and helps build and improve the domestic demand. MeitY during the year through the interaction with the stakeholders evolved a comprehensive roadmap for building a strong software product industry and thereby contributing equitably in the growth of IT sector.

To provide further impetus to Indian IT industry and more value addition in the Industry within the country, the Union Cabinet, chaired by the Hon'ble Prime Minister Shri Narendra Modi has approved the National Policy on Software Products – 2019 on February 28, 2019 to develop India as a Software Product Nation. The Policy aims to develop India as the global software product hub, driven by innovation, improved commercialization, sustainable Intellectual property (IP), promoting technology start-ups and specialized skill sets. Further, the Policy aims to align with other Government initiatives such as Start-up India, Make in India and Digital India, Skill India etc so as to create Indian Software products Industry of USD 70-80 billion with direct & indirect employment of 3.5 million by 2025.

The salient features of the policy are as follows:

- To promote the creation of a sustainable Indian software product industry, driven by

intellectual property (IP), leading to a ten-fold increase in India share of the Global Software product market by 2025.

- To nurture 10,000 technology startups in software product industry, including 1000 such technology startups in Tier-II and Tier-III towns & cities and generating direct and indirect employment for 3.5 million people by 2025.
- To create a talent pool for software product industry through (i) up-skilling of 1,000,000 IT professionals, (ii) motivating 100,000 school and college students and (iii) generating 10,000 specialized professionals that can provide leadership.
- To build a cluster-based innovation driven ecosystem by developing 20 sectoral and strategically located software product development clusters having integrated ICT infrastructure, marketing, incubation, R&D/testbeds and mentoring support.
- In order to evolve and monitor schemes & programmes for the implementation of this policy, National Software Products Mission will be set up with participation from Government, Academia and Industry.

In order to implement the Policy, the followings activities have been initiated:

- A National Software Product Mission (NSPM) has been constituted under the chairmanship of Joint Secretary (NPSP) to evolve and monitor schemes, programmes and strategy for the implementation of National Policy on Software Products (NPSP 2019).
- An Apex Committee under the Chairmanship of Secretary, MeitY has also been constituted to monitor the progress of National Policy on Software Product-2019 and also to evaluate the major decisions of National Software Product Mission time to time.

- 1st meeting of the National Software Product Mission has been held on August 19, 2019 at STPI, Bengaluru. During the meeting various issues of Software Products ecosystem were deliberated including creation of Indian Software Products Registry, Model HSN code, Software Product Development Fund, Research and Innovation Fund, Next generation Incubation Scheme, Start-up Accelerator programme etc.
- Indian Software Product Registry (ISPR) has been created to analyse numbers/ statistics/ database of Indian Software Product Companies (ISPC) and to bring all software products at one single platform. The registry (www.ispr.gov.in) has been launched launch on 21st October during MeitY Start-up Summit in New Delhi.
- In order to recognize and cultivate the entrepreneurial spirit in women and inspire the next generation of women to lead the Indian digital era in software product sector, seven Women entrepreneurs have been awarded by Rs. 2 Lakhs each in 6 categories by Hon'ble MEIT, Shri Ravi Shankar Prasad.
- MeitY is in process of formulating a Model RFP template for software Products. In this regard, the 1st meeting of expert group committee was held on November 21, 2019 in New Delhi. As per recommendation, an initial draft of Model RFP template for Software Products and another template for system integrator converging software products and software services are being prepared.

4.7.2 International Projects in ICT

To showcase India's prowess in IT/ITeS, MeitY has been assisting the Ministry of External Affairs to execute a number of projects in developing and least developed countries. Under such initiatives, more than 40 Centers of Excellence on IT, IT

Parks, Capacity Building Institutes, tele-medicine and tele-education facilities, e-network have been established till date. During the year, India-Kazakhstan Center of Excellence in ICT at Astana, Kazakhstan, Setting up of Computer Labs at 37 Schools in Tajikistan and Strengthening of India – Myanmar Centre of Excellence in ICT in Yangon were completed and operationalised. Also following projects are under execution and initiated during the year:

Completed/ Ongoing Projects during FY 2019-20

- Centre of Excellence in IT in San Jose – Costa Rica
- Centre of Excellence in IT in Roseau – Commonwealth of Dominica
- Setting up of computer labs in 50 schools under Vayots Dzor region in Armenia
- Setting up of a sustainable IT Infrastructure for Advanced IT Training using conventional, virtual classroom & e-learning technologies in Phnom Penh -Cambodia
- Setting up of a sustainable IT Infrastructure for Advanced IT Training using conventional, virtual classroom & e-learning technologies in Myitkyina – Myanmar
- Setting up of a Sustainable IT Infrastructure for Advanced IT Training using conventional, virtual classroom & e-learning technologies in Vientiane – Lao PDR
- Setting up of a sustainable IT Infrastructure for Advanced IT Training using conventional, virtual classroom & e-Learning technologies in Hoi Chi Minh City – Vietnam
- ICT Resource Centre at Nelson Mandela African Institute of Science & Technology in Arusha – Tanzania
- Setting up of Centre of Excellence in IT in Cairo – Egypt

- Setting up of Centre of Excellence in IT in Casablanca – Morocco
- Up-gradation of existing IT Infrastructure and associated software at CARICOM Secretariat in Guyana & Offices in Barbados & Jamaica
- Accreditation of India – Myanmar Centre for Enhancement of IT Skills in Yangon as Authorized Training Centre of CDAC for 3 years
- Setting up of Centre of Excellence in IT in Port Moresby – Papua New Guinea
- Setting up of Centre of Excellence in IT in Vanuatu in Port Vila – Vanuatu
- Setting up of Centre of Excellence in IT in Apia – Samoa
- Setting up of Centre of Excellence in IT in Alofi – Niue
- Setting up of Centre of Excellence in IT in Suva – Fiji
- Setting up of Centre of Excellence in IT in Nauru
- Setting up of Centre of Excellence in IT in Rarotonga – Cook Islands
- Setting up of Centre of Excellence in IT in Georgetown - Guyana
- Special Training Programme under ITEC for trainers from CsEIT in several countries
- Setting up of India – Namibia Centre of Excellence in IT in Windhoek
- Supply of 150 Desktop Computers & Associated Software to Sao Tome & Principe
- NexGen Centre of Excellence in IT (NexGen CoE IT) in Tunis – Tunisia
- Capacity Building in Research, Development & Innovation in ICT & Electronics in Ghana through India – Ghana Kofi Annan Centre of Excellence in IT (AITI – KACE) by CDAC
- Accreditation of Jawaharlal Nehru India – Uzbekistan Centre of IT in Tashkent as ATC of CDAC for 5 years
- Accreditation of India – Peru Centre of Excellence in IT in Lima as ATC of CDAC for 4 years



Chapter – 5

Innovate and Design in India



5.1 Creation of Research Eco-System

5.1.1 National Supercomputing Mission (NSM)

National Supercomputing Mission (NSM) for building Capacity & Capability has been launched by Government in 2015, which is to be jointly steered and implemented by MeitY and DST over a period of 7 years. The programme is being implemented by C-DAC and IISc.

The main objectives of the mission are:

- Creation of state-of-the-art HPC facilities and infrastructure to enhance the national capability to enable cutting-edge research in various domains in solving grand challenge problems.
- Development of HPC Applications for major Science and Engineering domains.

- Promote Research and Development in HPC leading to next generation Exa-scale computing readiness.
- Human Resource Development to handle and spearhead HPC activities in the country.

An integrated approach is being followed for building systems with scalable architecture, ranging from workstation class having performance of a few teraflops to single rack mid-range self-contained systems with performance of 100 teraflops to high end systems with performance up to 10s of petaflops.

It is planned to establish several supercomputing systems of different computational powers in various academic and R&D institutions in India. These systems will be deployed using both Build approach and Buy approach. Major focus is on Build approach to implement HPC systems under this mission.



Supercomputers PARAM Shakti

Under Build approach it is envisaged to design and manufacture the sub-systems of HPC system locally in India. C-DAC is entrusted with building systems indigenously in phased manner (Phase-I: Assembly in India, Phase-II: Manufacturing in India, Phase-III: Design and Manufacturing in India) with all the phases to start simultaneously.

Progress:

- In phase-I, C-DAC has already commissioned two systems of 650 TF each at IIT (BHU) Varanasi & IISER Pune and one system of 1.3 PF at IIT Kharagpur.

Under Phase-II order has been placed to deploy three more systems at IIT Kanpur, IIT Hyderabad, and JNCASR Bengaluru. NSM-TAC has recommended installation of 12 systems in Phase-II subject to availability of funds. The total capacity will be 10.4 Peta Flops.

Under The Phase-III design, development of server motherboard and Open 19 based hardware frame work is in progress.

- Four pilot systems of 100TF with different technologies (Intel, IBM, ARM & AMD) have been planned to evaluate for deciding technology most appropriate for Phase-III design. The systems once developed can be deployed as per requirement of mission. The first 100TF system with Intel Skylake processor has already been built and put under operation.
- Under Build Approach R&D, various activities have been taken up such as development of indigenous sever node, interconnect switch, storage and system software stack. Design of indigenous server mother board (Rudra) based on Intel processors is complete and is under testing.
- Development of a next generation HPC network “Trinetra” that is scalable to higher speeds offering world class performance for use in HPC systems is in progress. Board design of interconnect switch (Trinetra) for 40/100 Gbps with an aggregated bandwidth

of 240/600 Gbps (which is state of the art as on date) is complete and is under testing

- Development of critical system software components and tools is in progress. First version of HPC system software stack for Phase-I and Phase-II systems is complete and installed on Phase-I systems. Improved version of the stack is a continuous process.
- Application development in the areas of weather and climate modelling, Genomics and drug discovery, Seismic imaging, Flood Early Warning and Prediction System, Materials and Computational Chemistry have been initiated in consortium mode involving C-DAC, academia, and industry. The projects are progressing.
- Development of indigenous HPC processor has been initiated for future HPC systems.
- Under HRD development, three types of courses have been evolved and syllabus drafted
 - Short term (1-2 weeks): Faculty Development Programmes etc.
 - Medium term (6 months): Post Graduate Diploma
 - Long term : UG and PG curriculum

So far, 20 training events have been conducted and 978 persons participated.

5.1.2 R&D and IP development

5.1.2.1 R&D in IT

- **Quantitative assessment tools for analyzing the degree of facial paralysis:** A project is being implemented by IIT Hyderabad in the area of healthcare to develop quantitative assessment tools for analyzing the degree of facial paralysis during treatment of the patient using machine learning and computer vision tool.

- **Artificial Intelligence (AI) Driven High Throughput Phenotyping:** A project has been initiated at IIT Hyderabad to develop High Throughput Phenotyping and crop management techniques for the efficient, cost effective, non invasive and automated measure of the phenotyping traits. This would significantly improve the current cultivation and breeding practices to improve yield.
- **Visual Speech Training Software for the Hearing Impaired:** A Computer-based tool for visualization of the vocal-tract, for providing visual feedback of speech articulation/parameters for the Hearing Impaired Children is being implemented by Digital India Corporation (DIC) and IIT Bombay. This technology aim for enhancing the quality of life and competitiveness of persons with hearing impairment.
- **Forest Fire Detection System:** The forest fire is one the major threat to the environment. A large area of Indian forest is affected by forest fire. A project has been initiated to detect forest fire in real time with the help of wireless sensor network and drone. The pilot system would be deployed in North Eastern State by C-DAC Chennai & Silchar.
- **Anaemia Detection Kit:** A large population of India is badly affected by Anaemia which is a serious public health problem as Anaemia affects physical and mental development of an individual. A project is being implemented by NIT Durgapur to develop a Smartphone Based Artificial Intelligence Enabled Portable Low-cost non-invasive Anemia Detection Kit.
- **Diagnostic System for Alzheimer's Disease (AD):** A research project has been initiated at NBRC, Manesar to develop a technology for early predictive diagnostic system for AD. The system would be able to determine AD onset and its progression to provide early diagnostic markers.

- **“Krishi Mantrana”:** An AI Based Multimodal Dialog-System for Farmers. A project is being implemented jointly by C-DAC Noida, C-DAC Kolkata, Birsa Agricultural University (BAU) Ranchi, Animal Sciences University, Patna to development of An Artificial Intelligence based System to provide advice and to address farmer’s field queries in Hindi and Bengali language.
- **Development of Tool(s) for Enabling Binary Program Analysis:** Binary analysis is an important requirement for checking the quality of the software and finding out the bugs. Tools for conversion from assembly code to IR are very critical. A project has been initiated jointly at C-DAC, Hyderabad & SASTRA University, Tamil Nadu for the development of translation tool(s) (working prototype) for converting assembly code to LLVM (open-source compiler infrastructure for lifelong program analysis) IR (intermediate Representation) for MIPS architecture.
- **Big Data Analytics for Crime Deterrence:** The homicide and property crime rates are the drivers to push the need and urgency to forecast the statistics prevalent in India. A project has been initiated at C-DAC, Chennai to develop an analytics engine around the data services provided by the crime branch and it’s supporting agencies to leverage the Intelligence to uncover security, fraud and cyber detection case using big data framework.
- **Ferm to second laser approaches to Quantum Information and Computation:** A project being implemented by IIT-Kanpur towards developing scalable model of quantum information processing and computing with optical approaches. It addresses the international quest towards developing scalable quantum computer.

A project Post-Quantum digital signature for document signing has been initiated at Society for Electronic Transactions and Security (SETS) Chennai to analyze, implement, benchmark digital signature schemes which are resilient to attacks by quantum computers.

5.1.2.2 Microelectronics Development and Nanotechnology Initiatives

- i. Under Microelectronics Development, 11 Patents (National/International) filed and about 300 research papers have been published/ presented in National/International journals and conferences of repute in FY 2019-20. The details of National/International Patents are as follows:
 - A current source array for high resolution high speed digital to Analog converters.
 - A lateral DMOS transistor and method of fabricating thereof.
 - An ultra low power read decoupled-differential write, 10T SRAM cell with larger read/ write noise margin.
 - Offset compensated data sensing technique for low energy embedded RAM.
 - Ultra low trans conductance amplifier using carbon nano tube field effect transistor.
 - Power supply noise reduction using clock gating with variable frequency as global clock.
 - Internet of things enabled energy management system.
 - Method and System for enriching life in a humanly maintained aquaculture environment.
 - A novel microfluidic approach for bio-mems applications.

- Fully differential clocked comparator for pipelined analog - to - digital converter.
 - Polymer electrostatic MEMS cantilever beam.
- ii. Under Nanotechnology Initiatives, more than 60 research papers have been published in National and International journals. Some of the International Patents published/filed this year are as follows:
- Microfluidic POC-immunosensor for Non-invasive Plasmonic Detection of Tear Biomarkers.
 - Point-Of-Care Detection of Ethanol in Human Breath and Other Analytes.
 - Highly Fluorescence ‘J-shaped’ Multifunctional Thermally Activated Delayed Fluorescence (TADF) and Stimuli Responsive Organic Luminogens (SROL) for Lighting Applications and a method for attaining said TADF from an Inaccessible Near-IR Room Temperature Phosphorescence.
 - A High Efficiency Polymer Solar Cell and a Process for Fabricating the same.
 - Functional Group Engineering in Naphthalimides to Fine-Tune the Supramolecular Self-Assembly and Condensed State Luminescence.
 - PTB7-Th donor polymer based Donor-acceptor (D-A) conducting polymer (CPs) suitable for polymer solar cells (PSC) and devices thereof.

5.1.2.3 Convergence, Communications & Broadband Technologies and Strategic Electronics

R&D initiatives in Convergence Communications, Broadband Technologies and Strategic Electronics is aimed at developing indigenous capability in the thrust areas which include - Next Generation Communications & Convergence technologies

(Massive MIMO, Software Defined Radio(SDR), Software Defined Networks(SDN), Network Function Virtualization (NFV), Cognitive Radio, Heterogeneous Wireless Networks); Green Communication; Cyber Physical Systems, Internet of Things (IoT) & Machine to Machine (M2M) Communications, Wireless Sensor Networks; Convergence of wired/wireless networks and fixed mobile convergence; ICT applications in strategic sector; Broadband Wireless Access Technologies; Visible Light Communication (VLC), Vehicular ad-hoc Networks (VANET); IP based products/services; Electro-magnetic wave applications; High power RF/microwave tubes; Terahertz (THz) wireless systems; ST Radar Systems etc.

Achievements

A number of technology development projects initiated at various institutions/R&D organisations across the country in the thrust areas were successfully completed. Next Generation Communications and Convergence have yielded in notable achievements in the year which include “5G Research and Building Next Gen Solutions” project was implemented with consortium of 5 premier academic/research institutions collaborating to do advanced research in 5G technologies, participate in global standardization and develop advanced simulation and technology prototypes for 5G. During this period, 02 US patents and 11 Indian patents have been awarded. An advanced 5G broadband wireless simulators (BWSIM) was developed.



ST Radar site



T/R Module ST Radar

ST Radar for prediction of accurate weather patterns and providing warning of severe climatic conditions for NE states has been installed and commissioned at Gauhati University.

Some of the technologies developed/being developed indigenously under the R&D projects are as follows:

Safety Alert Systems using Dedicated Short Range Communication for on Road Vehicles (SAFEDRIVE): As a part of the SAFEDRIVE project, On Board Unit (OBU) & Road Side Unit (RSU) hardware and DSRC Wireless Access for Vehicular Environment (WAVE) stack were developed for providing Vehicle-to-Vehicle (V2V) communication as well as Vehicle to Infrastructure (V2I) communication. The products developed would enable two-way communication that can contribute to safer driving and provide various applications that use the secure V2V and V2I communications. The field trial of the complete system has been carried out at Srisailam Highway, Hyderabad.



On Board Unit (OBU)



On Board Unit (Mini)



Road Side Unit (RSU)



RSU deployment

Collaborative Data Processing and Resources Optimisation for Post Disaster Management and Surveillance using Internet of Things:

Developed a test bed for Internet of Things consisting IP enabled devices and heuristic solution and metric for intelligent information processing network architecture proposed, developed GUI for resource allocation, distribution, sensor live visualization, network and cluster visualization, clustering and routing algorithms, image



Drone payload

Other R&D initiatives are: Design of Robust Communication Receiver based on OFDM in Interference Limited Channels for TVWS (IEEE 802.22), Low Power Terabit for Broadband Communication Links, QoS Provisioning in Internet of Things (IoT) etc.

Ongoing Activities

The on-going projects supported in the identified thrust areas include Converged Cloud Communication technologies, Energy Management in Wireless Sensor Networks, Development of Unified IP based Communication Platform for Voice, Video, data, Messaging and Chat services,, Collaborative Data Processing and Resources, Big Data, Internet of Things and Cloud Computing: architecture, Issue and Application in Indian perspective, Development of National Disaster

Spectrum and Disaster Communication Backbone architecture (DiCoBA) with Prototype Development, Development of Digital Mine Using Internet of Things, Design and Development of Antennas for Communication in TV White Space Frequency Band etc.

Under Indo-Dutch collaboration, for collaborative research in Pervasive Communications & computing five projects are in progress:

- Code self-verification for IoT devices: A IoT prototype test bed has been developed at BITS, Pilani, Hyderabad Campus for intelligent decision making and prediction of events in real-time and persistent delivery of information has been developed. Tamper-proofing techniques were developed to make the life of adversaries difficult by using Return Oriented Programming on IoT devices.
- Operations and privacy aware smart public buildings: As part of project a smart building testbed is being developed integrating heterogeneous sensors and communication technologies (Wi-Fi, Bluetooth, LoRa, etc.) to collect the sensed data, visualize and analyze it to learn, predict and act in accordance to desired subsystem functionality.
- Big imaging data approach for Oncology: Big Data technology is being developed that opens up petabytes of medical imaging data stored in hospitals worldwide and use it to learn in decision support systems for cancer treatments
- Data mining & prediction in airlines: Airline Crew Pairing Optimization framework has been Developed and Tested for real-world airline data.
- Crowd control Management for Kumbh Mela using Big data: Crowd Simulation on Crowd Simulator and Crowd Management Guidelines for Mass Religious Gatherings has been developed.

The promotion of R&D in the area of applied microwave electronics & engineering is being further strengthened by establishing two centres of SAMEER. Centre specializing in high power microwave tubes/ components, in collaboration with IIT Guwahati is being established. The Centre will focus on R&D of 3.1 MW magnetron at 2.998 GHz, design and development of 3 kW circulator at 2.998 GHz and 6 kW RF load at 2.998 GHz. Another Centre for Electromagnetic Environmental Effects (E3) is being established at Visakhapatnam for highly specialized state-of-the-art EMI/EMC test facilities including Electromagnetic Pulse (EMP) and Pulse Current Injection (PCI) set up to meet the requirements as per International EMC Standards, which is unique facility in the country to address critical Infrastructure protection against EMP to qualify defense electronics systems as per the EMP requirements. India's largest outdoor RS105 EMP test facility along with other highly specialized facilities like Pulsed Current Injection (PCI), UltraWide Band Test Facility, EMI/EMC testing laboratory and 3D Modelling and Analysis Laboratory have been established successfully.



EMP Facility

New Initiatives in the 2019-20

Three projects in the 2nd phase of R&D collaboration between MeitY and NWO in the areas of IoT, Big Data and Emerging Technologies in ICT have

been initiated. Some of new projects are: Design and Fabrication of Autonomous Passenger Drone, Acoustic Gunshot Detection System for Strategic Applications, Development of SDN and NFV based Agile Network Service Delivery Platform for Enterprise and Service, Cognitive Radio for Strategic Applications, Development of a prototype wideband RF frontend & Waveform for Spectrum Sensing based Interference Mitigation, Development of 4G/5G based UAV Augmented Intelligent Monitoring and Surveillance System, Conformal Jamming Systems for RCIED, Development of Multi-Option Proximity Sensors (MOPS) for Artillery and Mortars, Visible Light Communication based LED Lighting Solutions, Design of Dynamic MAC and PHY SoC for Low Power and Long Range Networks, Intelligent Video Surveillance and Video Analytics System, Efficient Multicarrier Waveform Design for Next Generation Non-Orthogonal Multiple Access for Wireless Mobile Communication.

5.2 Translation R&D

5.2.1 Initiatives under Electronics Components and Material Development

Electronics Components & Material Development Programme (EMDP) has been promoting research and development activity since 1986 to nurture electronics development in the country for boosting local manufacturing. EMDP's core areas of research are Electronics Materials, Components and process technology, Photonics and Electronics Waste Recycling (E-waste). The current focus of the program is development of technologies in the areas of energy storage, printed circuit board substrates, optical technologies including optical fiber, indigenization of optical components, antenna, absorbers, environment & E-waste and process technology development leading to product development and technology transfer to industries. In this regard, EMDP is focusing on

creation of Centre of Excellences in the areas of E-waste, rechargeable battery (Li-ion and Na-ion), Integrated photonics (silicon photonics) and Additive Manufacturing.

Three technologies in the area of E-waste PCB recycling are under process for technology transfer. After development, nine other technologies in the areas of digital thermometer, graphene through chemical route, microwave substrates, transparent heater, aerogel based supercapacitors, piezoelectric compositions and components, graphene supercapacitors technology, lead free X-Ray absorbing material & medical apron technology and EMI shielding are ready for technology transfer.

In last ten years, a total of 81 patents families have been filed under EMCD; out of which 71 are in National Phase and 20 are in International Phase of filling. During the same duration, 8 technologies have been transferred to industry. This year three

new patents have been filed in the area of EMI Shielding and E-waste Recycling Technologies. Schematic showing year wise EMCD patent filling is provided in figure below:

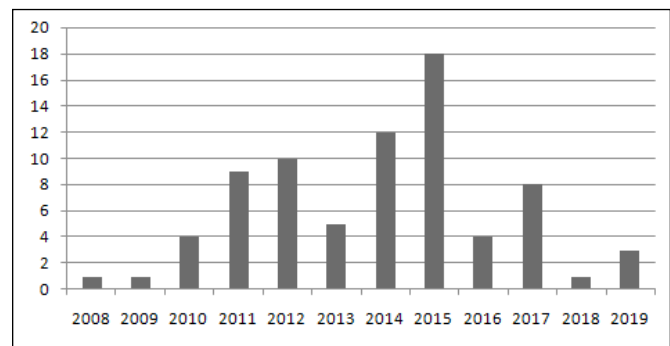

EMCD Patent families

Projects in Progress

- **E-waste Recycling- recovery of metals from spent printed circuit boards:** Technologies for end-to-end recycling of e-waste has been demonstrated by setting up plant at



Electro-Refining unit (Skg/day Deposition rate)

Anode Mud Leaching Unit

Bengaluru for printed circuit board (PCBs) in a environmentally safe manner. This facility can carry out PCB recycling capacity of 1 MT (i.e. 35MT of e-waste)/day. A tabletop model of smaller recycling capacity of 100kg of PCB (3.5MT of e-waste) /batch has also been set up at C-MET Hyderabad. The transfer of technology for 100Kg/batch is under progress for setting up of various PCBs recycling plant in other parts of country. The waste plastics from e-waste have also been converted to value added product through a successful research project at Central Institute of Plastics Engineering & Technology (CIPET), Bhubaneswar. E-waste contains nearly 27% of the plastics. The development had taken care of converting these plastics with improved performance in environmentally manner. The process is capable to convert majority (76%) of the waste plastics to suitable master batch, which could be used for virgin plastic products. The toxicity and environmental tests were carried out on the developed products from the master batch, showed acceptable standard. 230kg of PCBs from dismantlers from Gurgaon and Hyderabad has already been processed as part of the technical service. A technology of 100 Kg/ day batch scale has been transferred to M/s Namo E-waste Management Ltd., Faridabad.

- **Supercapacitor-based power modules (SCPM) for applications in VVPAT of**

EVM: C-MET has developed complete indigenous technology for making of aerogel supercapacitors and supercapacitor packs of values (cell: 0.47-50F & Packs: 125-300 F) for various electronics and energy storage applications and demonstrated the technology by establishing the semi-automated Plant for production of carbon aerogel in pilot scale of 3-4 kg/batch per day. C-MET has also designed & fabricated machineries indigenously for fabrication of aerogel electrodes, winding & packaging. Based on the success of the technology MeitY has now initiated development of supercapacitor-based power modules (SCPM) for applications in next generation of Voter verifiable paper audit trail (VVPAT) machines of Electronic Voting Machine, in which the SCPM would compensate the use of large numbers of high power special Manganese dioxide based battery packs. CMET has started making SCPM of 33.3 F which are going through testing at ECIL. The product has won “Innovation Pavilion” award at ADMAT 2019 of DRDO. CMET has now developed 25F pouch cell ASC supercapacitors which are undergoing optimization of size and ESR.

- **Magneto-dielectric Printed Circuit Board Substrates:** Magneto Dielectric (MD) materials are artificially developed materials with permittivity and permeability values greater than unity which gives the material



properties that can miniaturise antenna and components operating at Ultra High Frequency Range (UHF) and Very High Frequency Range (VHF) with minimal impact on the bandwidth of the antenna, achieving designs closer to the fundamental limit of electrically small antenna. Good frequency stability has been shown for relative permeability (>2.5) and permittivity (>6) at 1GHz with appropriate loss tangent ($\tan \epsilon < 0.01$ and $\tan \mu < 0.03$) for rigid substrates. Conformal antenna technology with flexible substrate (200 mm x 150mm and thickness 1mm) based on rubber matrix is now under development in collaboration with DRDO for 400 MHz applications.

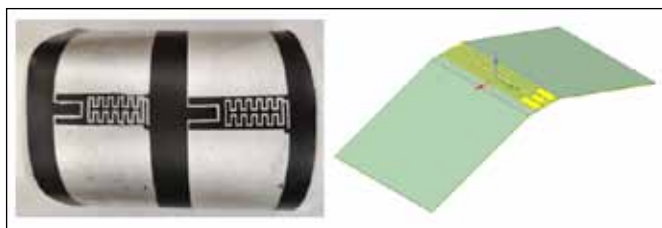

- Mode Division Multiplexing using Few Mode Fibers:** The bandwidth required in short and long-haul communication systems is increasing dramatically with the advent of advanced wireless communication systems and the proliferation of data centers. The maximum achievable capacity of single mode fibers used commercially today is limited by the nonlinear effects in the fiber. The use of space division multiplexing – with multicore and few mode fiber (FMF) is expected to increase capacity in long haul and access networks. A technology demonstrator program for the technology has been undertaken at IIT, Madras. Three technologies digital signal processing algorithms for two mode fiber transmission system, finite difference method based mode solver and stochastic parallel gradient descent algorithm based model decomposition are ready for transfer.

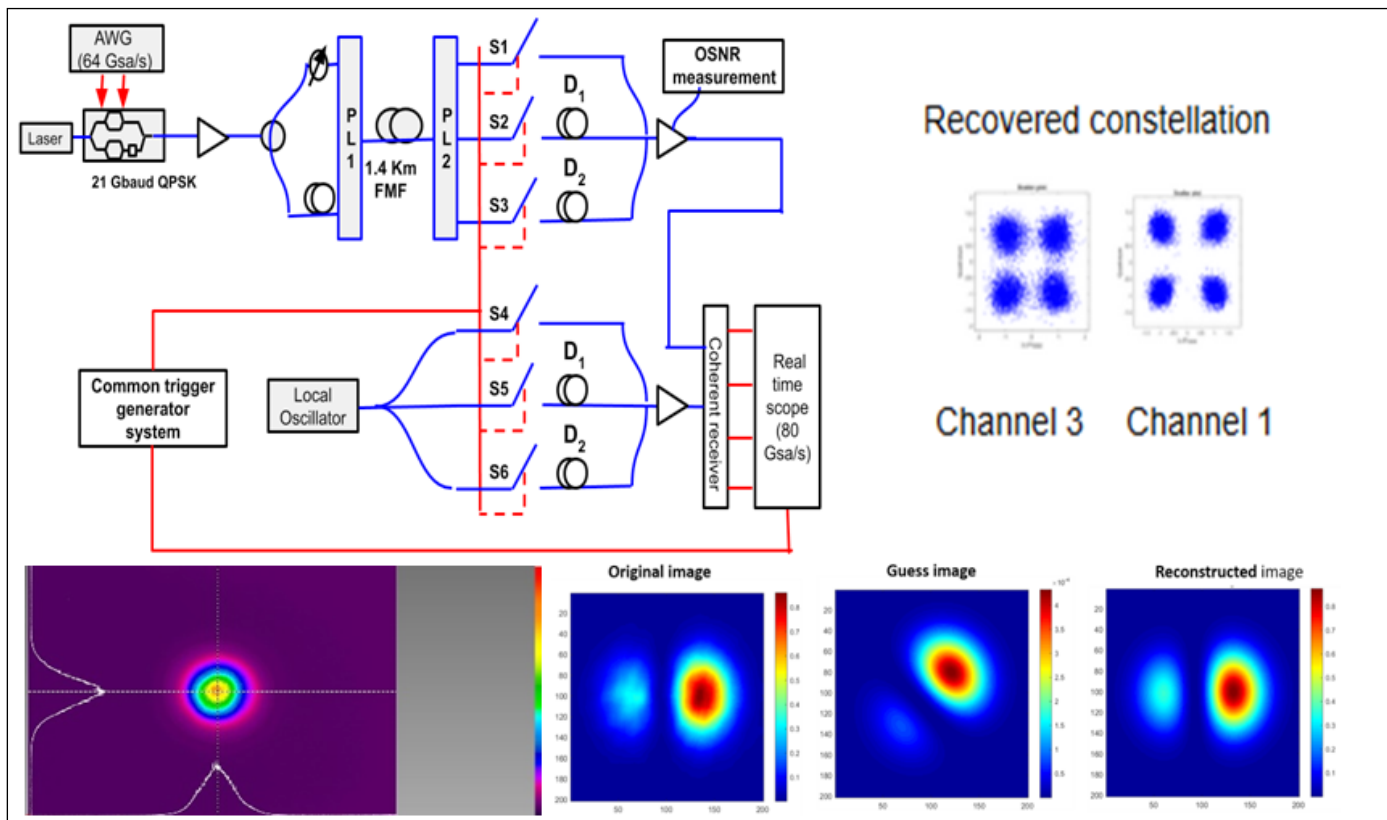

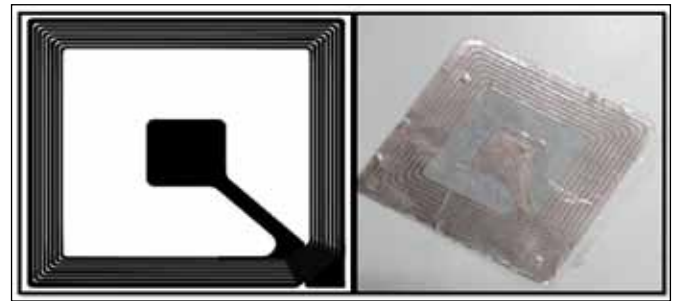
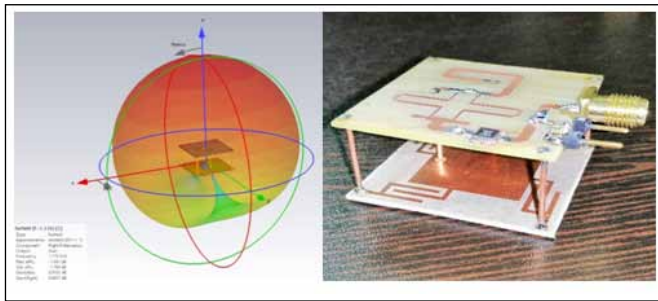

- Indigenous Antenna for Navigation with Indian Constellation (NavIC) Antenna:** NavIC is indigenous independent regional navigation satellite system developed in the country. NavIC is expected to be better (~5 meters) as compared to GPS (~20 meters) system. Development of suitable microwave substrates and L1, L5 & S band antennas for NavIC system has been undertaken by MeitY through C-MET. C-MET has already developed variety of ceramic filled PTFE based microwave substrates, patented their IP rights and transferred the technology to industry for commercial production. Based on this base technology and further tuning of properties of the material, miniaturized NavIC antennas are being developed. Initial demonstrations have shown successful locking of satellites.
- Printable Silver thick film ink for RFID Tags:** Technology development for indigenous printable silver ink has been undertaken by MeitY through CMET for RFID tags. Antenna tag for ultra-high frequency (UHF)

and Microwave range (869 MHz, 902-928 MHz and 2.45 GHz) RFID applications has been made and being demonstrated using the indigenous printable silver ink on flexible substrate.

- Hybrid battery power module with indigenously developed super-capacitor and Li-ion cell:** Carbon is the largest input raw material by weight for lithium ion cell and supercapacitors. A technology development for Li-ion battery and supercapacitor cell based on North-East coal as carbon has been initiated by MeitY through CSIR-NEIST, Jorhat. Hybrid power module will be developed based on these cells to power e-rickshaw. The project CI has been awarded the Prof (Dr) Mahendra Pratap Singh Memorial Coal Science Award for 2018-19 by MGMI (Kolkata).
- EMI Shielding materials:** Electro Magnetic Interference (EMI) shielding materials with thickness less than 4mm having an absorption of at least -20 dB and covering a bandwidth of approximately 2-4 GHz in X and C band



are under development. The material will be light weight, conformal, with high mechanical stability and cost effective. Such materials are used for strategic stealth technology applications such as antenna shielding in naval ships. Development of material and products based on the material has been undertaken through University of Tezpur. Products such as single layered magneto-dielectric absorber in X-band (M-type strontium hexaferrite nanoparticle filler in LLDPE matrix), sandwich multi-layered absorber in X-band (magneto-dielectric nano-composite triple layered sandwich structures), FR-4 based metamaterial absorber in S-band, expanded graphite based metamaterial absorber in C-band and expanded graphite based meta-“atom” absorber in X-band have been demonstrated on the developed material. One patent has been filed in EMI Shielding.



5.2.2 Technology Development & Demonstration for Indian Industries

5.2.2.1 National Mission on Power Electronics Technology (NaMPET-III)

The National Mission on Power Electronics Technology Phase-III (NaMPET-III) programme has been initiated with an objective to strengthen the power electronics technology base in the country. Various activities like Technology

development, deployment, technology transfer, Awareness creation and strengthening the industry interactions with R&D and academic institutes through collaborative research are Progressing.

Activities in the area of Wide Band Gap Device to develop magnetic field / Current sensor, design & development of planar magnetic components and application of Low Voltage Direct Current (LVDC) in house boat, electrical vehicles charging system, deployment of micro-grid in Hubli have been initiated for technology development/ deployment. An industrial conclave on e-Mobility and four short term courses on specialized applications of power electronics have been conducted.

5.2.2.2 Realization of Series Connection of Silicon Carbide (SiC) Devices in Converters with High Frequency Link Bidirectional DC-DC Converter for Grid Interfaces

To design and develop Series connection of Silicon Carbide devices (for handling high current/voltage) in converters with high frequency link bidirectional DC-DC converter for Grid interfaces is progressing at CDAC-Thiruvanthpuram. Design of Active Gate Driver (AGD) for series connection has been completed and hardware testing of designed AGD is in progress. System on Programmable Chip based control invoking soft Processor with dedicated IP core required for realizing the vector control for the Dual Active Bridge has been completed.

5.2.2.3 Spectroscopic Platform for Detection of Adulteration in Milk

This project is progressing at CEERI, Pilani for development of a portable system for detection of adulterants like urea, sugar, maltodextrine, melamine and vegetable oil in milk through spectroscopic method. Experiments for detection of targeted adulterants using spectral bands near Infra Red Region have been completed and a prototype system has been developed.

5.2.2.4 Development of Electric Vehicle Sub-System

Keeping in view the present and future technological requirements of Electric Vehicles (EVs) and to enhance the local manufacturing of the subsystem, technology development in the areas of electric motor/controller etc., for EVs such as two wheeler, three wheeler, e-Rickshaws have been initiated at three institutes i.e. Delhi Technological University, New Delhi, IIT Kharagpur and IIT Madras in a consortium mode. EV sub-systems development consortium is comprising of Government R&D institutes/organization for the design and development, industry to commercialize it and vehicle manufacturer to use the developed products.

5.2.3 Medical Equipments/Tools

Deployment of 6 MeV Linear Accelerator (LINAC) for cancer treatment: Four 6MV LINAC were developed under the project. One LINAC Machine has been deployed at Indian Institute of Head and Neck Oncology, Indore is being used for patient treatment. On an average, 30 patients are being treated per day on this machine. The second LINAC machine has been installed and commissioned at Amaravati Cancer Foundation, Amravati. Treatment of Cancer patients has started since August 2018 with an average 30 exposures per day. The deployment of third LINAC Machine at BKL Walawalkar Hospital, Chiplun, Maharashtra is in progress and Mechanical alignments, calibrations, Optical-radiation-Mechanical congruence and sub-system wise QA, radiation testing has been accomplished. Identification of new hospital is in progress for deployment of the forth machine.

5.2.4 Initiatives under Microelectronics Development and Nanotechnology

Some of the technologies developed/ are being developed indigenously under the R&D projects

initiated by Microelectronics Development and Nanotechnology Initiatives Divisions are:

- (i) 64-bit SHAKTI Microprocessor by IIT Madras and 32-bit AJIT Microprocessor by IIT Bombay designed using Open Source Instruction Set Architectures (ISA) fabricated successfully at 180nm technology node of SCL Mohali. SHAKTI processor also got fabricated at 22nm technology node of Intel foundry.



64-bit Microprocessor by IIT Madras fabricated at SCL Mohali Foundry



64-bit Microprocessor by IIT Madras fabricated at Intel Foundry



32-bit Microprocessor by IIT Bombay fabricated at SCL, Mohali Foundry

- (ii) For effective use of Navigational services based on Indian Constellation of Satellites, named NavIC (Navigation with Indian Constellation), a proof-of-concept working prototype for NavIC User Receiver has been developed using integrating the indigenously developed RF & Digital Integrated Chips, Microprocessor and Navigation algorithms with Multi-Constellation support (i.e. NavIC (L5 and S frequency band) & GPS (L1 frequency band)) by SAMEER Mumbai in collaboration with IIT Mumbai, IIT Madras, IIT Jodhpur & IIST Thiruvananthapuram. The Standard Positioning Service (Position, Velocity & Time) offered by NavIC Receiver will find huge application in Terrestrial, Aerial and Marine Navigation particularly for- Disaster Management, Vehicle tracking and fleet management, Integration with mobile phones, Terrestrial navigation aid for hikers and travelers, Mapping and Geodetic data capture etc.
- (iii) Following five Transfer of Technology (ToT) have been transferred to M/s Primary HealthTech Private Limited from Centre for Nanotechnology at Indian Institute of Technology Guwahati:

- Point-of-Care-Testing Device for Fingerprint Bilirubin Detection

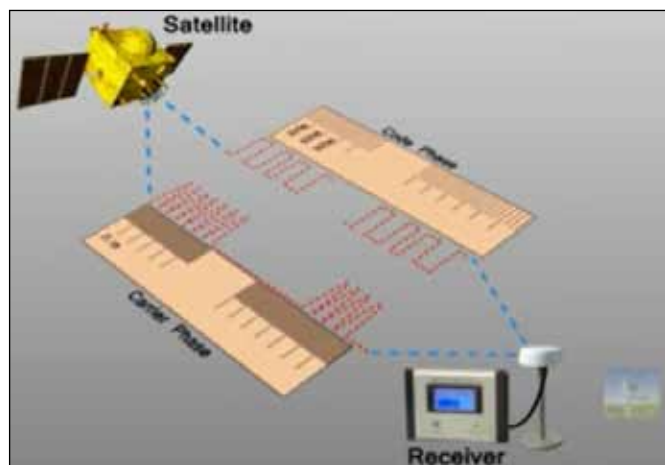

NavIC Receiver

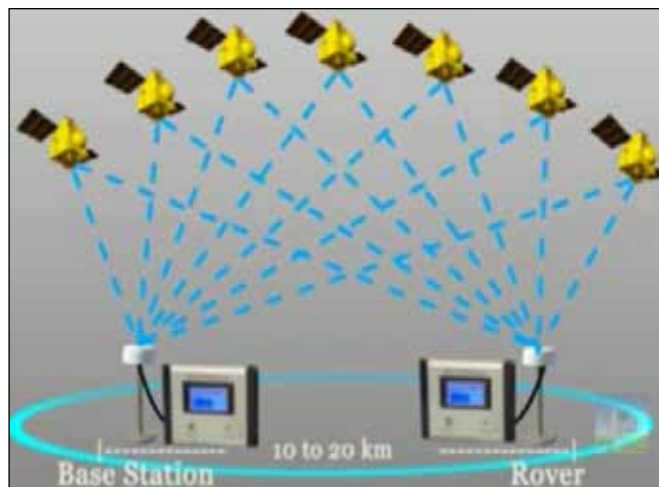

Constellation of 7 Satellites

- Point-of-Care-Testing Device for Pancreatic Amylase Detection
 - Point-of-Care-Testing Device to determine Albumin to Creatinine Ratio in Human Urine
 - Point-of-Care-Testing Device for Lung Condition Monitoring
 - Point-of-Care-Testing Device for Parkinson's Patients
- (iv) A start-up called M/s Primary HealthTech Private Limited has been incubated at Centre for Nanotechnology, IIT Guwahati.
- (v) A Project entitled "Nanoelectronics Network for Research & Applications (NNetRA)" being implemented by IIT Bombay, IIT Delhi, IIT Madras, IIT Kharagpur and IISc Bengaluru has been initiated in collaboration with DST & Implementing agency as an umbrella programme for a period of four years with the vision of making India Knowledge rich in Nanoelectronics. Under NNetRA following are the achievements :
- ToT for NO_2 , O_2 and N_2H_4 and H_2 sensors to SCL by IISc Bengaluru is in process. Field trials of these sensors are being performed at SHAR, Sriharikota

since April 2019 and results are being compared with that of commercial sensors. A universal transmitter which interfaces to all 4 types of sensors has been developed with analog front-end section, control interface section and transmitter section.

- Hollow micro needles able to pierce human skin successfully have been fabricated, characterized and tested to deliver required drug dosage without breaking. Integration of micro needle and micro pump through intermediate micro fluidic ports on a single platform has been designed and fabricated. These microneedles are being studied at AIIMS, New Delhi for Insulin delivery by in-vitro and animal studies for efficacy and safety followed by initiation of pilot clinical studies.
 - Technology has been transferred for soil moisture sensors developed by IITB and IISc to a start-up called Soils-Sens incubated at IITB. Around 70 soil sensors have been deployed at various fields to generate data base and reliability.
 - Prototype of Monolithic Microwave Integrated Circuits (MMICs) and RF modules for strategic and high-end applications using GaN High Electron Mobility Transistors (HEMTs) is being developed at IITB.
- (vi) Three-Dimensional Nanostructure based Miniaturized and Flexible rechargeable lithium batteries for flexible electronics are being developed at Centre for Materials for Electronics Technology (C-MET), Pune by using shape-conformable solid-state electrolyte / separators, flexible electrode materials for RFID applications.

5.3 Centres of Excellence

5.3.1 Nanoelectronics Centres

Nanotechnology Initiatives Division at MeitY has established several Centre of Excellence in Nanoelectronics at IISc Bengaluru, IIT Bombay, IIT Madras, IIT Delhi and IIT Kharagpur in various technology areas to take the basic R&D outcomes to the prototype upto the TRL of 4 or 5 and then to manufacture Nano devices, subsystems, systems for the social benefits. Subsequently a Nano Fabrication Prototyping Facility for SMEs and Start-ups in the area of Micro Electromechanical Systems (MEMS) & Nano Electromechanical Systems (NEMS) at IIT Bombay. This facility has been created, commissioned & fully operational to enable researchers and industrial partners/incubator companies to fabricate and manufacture nanoscale devices. This facility aims to provide facilities for scaling up of nano-manufacturing operations in contamination and quality controlled environment. Also it will be an accessible platform to bring technologies from Technology Readiness Level TRL 4 to TRL 9. Fabrication unit processes have been optimized for silicon to release diaphragms, fabrication of microcantilevers and micro-heaters. Also a Centre for Nanotechnology at IIT Guwahati has been created to provide a platform for the scientific and technological developments in the area of theranostic devices. R&D efforts at this centre have resulted in many publications, patents, proof of concepts, prototypes and transfer of technologies based on chemical, biological, and environmental sensors, transistors and MEMS/NEMS applications.

E-waste

The purpose of establishing Centre of Excellence (CoE) in E-waste Management is to create physical infrastructure and knowledge hub for the development of cost-effective technology for E-waste recycling and dissemination of E-waste

solutions from dismantling to recycling to precious metal separation in collaboration with Government, Industries, and academia. This will enable the empowerment of informal E-waste recyclers in the country, safe disposal of end of life electrical and electronic devices, recovery of precious metals from E-waste, strengthening of current engineering ecosystem to improve the process efficiency, vanquish the export of PCB boards, safe recovery of precious metals and thereby huge savings on foreign currency, dissemination of knowledge base for human resource development, Skill development for prosperous entrepreneurs, and nurturing of start-ups.

The CoE will host a physical lab facility to create a prototype for addressing the various domestic needs in the field of E-waste eg. dismantling, plastic recycling, designing and automation of various process equipment for environmentally friendly recycling of PCBs, recovery of precious metals, separation of rare earth oxides from spent phosphors and permanent magnets, nurturing of start-ups etc. This facility will also include the incubation center to enable start-ups to develop their ideas. Providing training to empower the Indian electronics and electrical industries on the E-waste Management Rule (2016) through RoHS facility available at C-MET is another very important goal of the COE. The proposed partnership model, which is indicative, is presented in a matrix as follows:

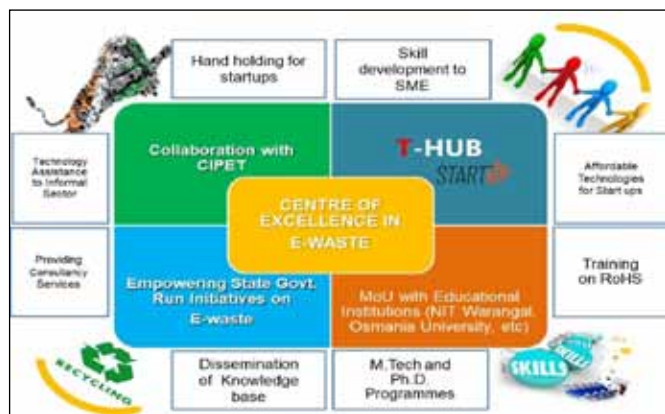

Rechargeable Battery Technology (Pre-cell)

Lithium Ion batteries are ideal power source for consumer electronics, e-mobility and power sectors (renewable and non-renewable). These batteries are also expected to find niche applications in e-governance electronics such as VVPAT machines. Current energy storage market in India includes applications such as solar rooftop, grid solar integration, wind integration, electric vehicles, inverter back-ups, telecom, UPS, rural microgrid and off-grid applications, diesel replacement, railways etc. India has vibrant Lead Acid battery manufacturing industry and needs to augment Li-ion battery cell manufacturing to meet current and future demands of energy storage. India primarily imports Li-ion cells and manufactures battery packs of different capacity for various applications. Government support in form of R&D funding for development of cost-effective end-to-end indigenous technology for manufacturing of rechargeable battery (Li-ion and post lithium) suited for Indian environment is vital for meeting the future demands. The support for R&D is expected to lower up-front investment cost, utilize Indian supply chain, improve profit margin and bring SMEs into play for manufacturing industrial units of rechargeable battery cell manufacturing ecosystem. In this direction, MeitY has recently initiated a Center of Excellence (CoE) on Rechargeable Battery Technology (Pre-cell) at CMET for scale up and transfer of indigenous technology on Lithium ion battery and Sodium ion battery (post lithium) to Indian SMEs for manufacturing of battery cells. The CoE will design and develop end to end technology with material localization based on business case for SMEs and attempt to create at least 25 start-ups in next five years.

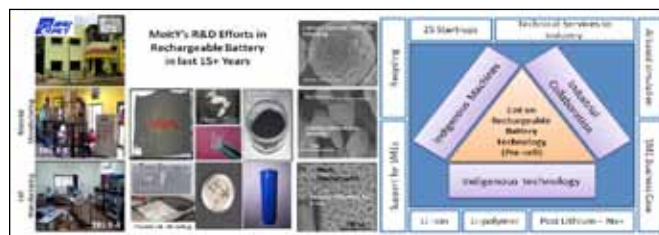

5.3.2 Innovation & IPR

India is home to one of the most vibrant startup ecosystems with close to 9000 tech startups, making it the 2nd largest startup ecosystem in the world. These startups are focused on verticals like healthcare, fintech, and e-commerce/aggregators and had created 40000 direct jobs with a total base of employment upto 1.6-1.7 lakhs (3.0-4.0x indirect jobs) in the last year. Adding over 1300 technology start-ups including 7 unicorns in 2019, making it to a total 24 unicorns active in India. A majority of these companies are in the ICTE space, even focusing on emerging technologies like Internet of things, Artificial Intelligence, Big Data, Machine Learning, Clouds etc. Several of the new age companies are raising money at valuations which far exceed the market capitalizations of many traditional and well-established players. However, many Startups do not reach their full potential due to limited guidance and access.

With nearly 3-4 new start-ups being launched every day, India has woken up to potential of startup ventures with great enthusiasm and energy. In the past two years, deals of over USD 15 Bn were concluded by technology start-ups. India's own ecosystem of startups is evolving rapidly. It is driven by the energy, enterprise and innovation of our youth.

Startup India

The Government of India has taken a number of initiatives with regard to boosting startup ecosystem. Startup India is a flagship initiative of the Government of India, intended to build a strong eco-system for nurturing innovation and Startups in the country that will drive sustainable economic growth and generate large scale employment opportunities.

Ministry of Electronics & IT (MeitY) has also taken various initiatives and measures to improve innovation-led ecosystem with a Technology

Incubation and Development of Entrepreneurs (TIDE) scheme, Centre of Excellences in IoT/ FinTech space, technology and theme based incubation centres and programmes to support researchers, start-ups and MSMEs protect IPRs nationally and internationally. MeitY has also launched an enhanced version of TIDE i.e. TIDE 2.0 scheme to promote technology incubation. A brief overview of such activities include:

Technology Incubation and Development of Entrepreneurs (TIDE) Scheme: Technology Incubation and Development of Entrepreneurs (TIDE) Scheme was put in place by MeitY in 2008 to promote innovation by nurturing startups in Information Technology, Communications & Electronics (ICTE) domain. Under the TIDE Scheme, financial assistance is provided to Institutions of Higher Learning to strengthen their Technology Incubation Centres for enabling young entrepreneurs to create technology startup companies for commercial exploitation of technologies developed by them. Under the scheme, 27 TIDE Centres and 2 Virtual TIDE centres have been supported at institutes of higher learning all over India.

The following are the main outcomes of the TIDE Scheme:

- 27 TIDE Centres and 2 Virtual TIDE centres supported at IITs/IIMs/NITs/Premier Institutes all over India.
- 207 startups benefited.
- 384 entrepreneurs emerged and out of which 34 are women entrepreneurs.
- 52 startups attracted Venture Capitalists resulting into investments of Rs172.39 crore
- Out of 207 startups, 95 have successfully graduated till date.
- More graduations likely to follow as some of the startups incubated in recent years.

- 74 successful patents registered based on the products developed by the startups.
- Till date, 243 products have been developed by these startups.
- 2846 jobs created throughout 27 TIDE Centres.

TIDE 2.0 Scheme: MeitY has launched TIDE 2.0 Scheme to promote tech entrepreneurship through financial and technical support to incubators engaged in supporting ICT startups primarily engaged in using emerging technologies such as IoT, AI, Block-chain, Robotics etc. in seven pre-identified areas of societal relevance. The Scheme is being implemented through 51 incubators through a three tiered structure with an overarching objective to promote incubation activities at institutes of higher learning and premier R&D organisations, eventually leading to handholding of approximately 2000 tech start-ups over a period of five years. The scheme also aims to provision a mechanism, whereby establishing necessary collaboration among the incubation activities so as to benefit them through complementary strengths. Efforts will be made to closely associate these incubators and through this network the complementary strengths can be leveraged and shared. This will also ensure that larger number of institutes possess matured incubation facilities, leading to technology start-ups moving out of metros to TIER 2 and 3 cities. To support tech startups addressing societal challenges in seven select thematic areas were identified based on national priorities particularly in the realm of:

- Healthcare
- Education
- Agriculture
- Financial inclusion including digital payments

- Infrastructure and transportation
- Environment and clean tech
- Clean Energy Solutions

To support technology startups, 41 TIDE 2.0 incubation centres approved under the scheme based on the Empowered Committee (EC) recommendations and announced by Hon'ble MEIT during the MeitY Startup Summit on 21st October 2019.

MeitY Startup Hub (MSH): In order to facilitate MeitY's vision of promoting technology innovation, start-ups and creation of Intellectual Properties, a nodal entity called 'MeitY Start-up Hub' (MSH) is now acting as a national coordination, facilitation and monitoring centre that integrate all the incubation centres and start-up and innovation related activities of MeitY. The vision of MSH is to build a conducive innovation ecosystem by bringing together various technology innovation stakeholders, breaking away with the culture of working in silos and paving the way towards a strong economy built on the twin engines of innovation and disruption. MSH to act as a hub and ensure synergies among all the TIDE 2.0 Centres, theme based incubation centres, Centre of Excellences on Emerging Technologies and other existing platforms for facilitating criss-crossing of technology resources, sharing best practices and ideas across the entire innovation and startup ecosystem. Through MSH portal, more than 1250 tech startups, 276 incubators, 177 mentors and 17 industry partners have been connected as on date for facilitating criss-crossing of technology resources, sharing best practices and ideas across the entire innovation and startup ecosystem. The MSH has been launched by the Hon'ble Minister, Electronics & Information Technology, on 21st October, 2019.



Launch of MeitY Start-up Hub (MSH) by Hon'ble Minister of Electronics & Information Technology

Domain Specific Centres of Excellence (CoEs) to be established with STPI:

A number of domain specific Centres of Excellence (CoEs) is going to be established by STPI pan India with the participation of MeitY, STPI, State Government, Industry partnership, VCs partnership as seed funding. In this series, total plan is to create 20 such domain specific CoEs with a corpus of Rs. 400 crore including MeitY contribution of Rs. 50 crore, STPI shall contribute a sum of Rs. 100 crore and rest stakeholders from industry/ VC/ State Government shall contribute of Rs. 250 crore. Out of the 20 domain specific CoEs, 9 CoEs have been established while 3 more CoEs are in different stage of consideration in MeitY.

Multiplier Grants Scheme: Multiplier Grants Scheme (MGS) is to encourage collaborative R&D between industry and academics/ R&D institutions for development of products and packages. There are two projects have been supported and one more project has been initiated under the scheme as on date.

Support for International Patent Protection in E&IT (SIP-EIT) Scheme for SMEs: A significant initiative of MeitY is the SIPEIT scheme which within a short span of time has become one of the flagship schemes of the Ministry. SIPEIT encourages international patent filing by Indian

companies-MSMEs. As of now, 55 applications from startups, MSMEs have been supported since the inception of the scheme. SIP-EIT aims to provide financial support to MSMEs and Tech startups for international patent filing so as to encourage innovation and recognize the value and capabilities of global IP. The scheme for a period of 5 years provides 50% reimbursement upto a maximum of Rs.15 lakhs to Indian MSMEs and Startups.

IP Awareness Programme for E&IT Sector: The aim of this scheme is to create a holistic sustainable model for creating IPR awareness among various stake holders. Till date, 83 IPR awareness workshops have been supported out of which 11 workshops have been supported in year 2019 with great success.

IPR Facilitation for MeitY R&D / Innovation Outcomes: To translate the Ministry's various efforts for creating state-of-the-art R&D paradigm in the country, MeitY has been supporting its R&D societies and grantee institutions in filing IPRs which includes patents, copyrights, industrial designs and trademarks. MeitY's IPR portfolio now consists of a total of 66 granted patents with 285 patents filed, 495 copyrights granted out of 529 copyrights filed and 93 registered Trademarks out of 168 Trademarks filed.

Centre of Excellence (CoE) in Intellectual Property Rights: With the growth of the IT industry as well as other technical sectors, an urgent need is felt to protect the IPR generated out in India. To cater this aim, a Centre of Excellence (CoE) on Intellectual Property Rights (IPR) is being implemented by CDAC, Pune and operational at MeitY and CDAC Pune. Apart from prior-art search, CoE on IPR is offering a bouquet of services in order to create awareness around the opportunities for protection of technologies which are outcomes of innovation and creativity.

Centre of Excellence (CoE) on FinTech at Chennai: MeitY has initiated a Centre of Excellence (CoE) on FinTech at STPI, Chennai to provide infrastructure, resources, coaching/ mentorship, technology support and funding to emerging start-ups in the FinTech sector. The FinTech CoE would establish ecosystem around FinTech with the latest trends and technologies in the financial services sector through a collaborative approach including NPCI, UIDAI and Partner Banks. The purpose of the FinTech CoE is to create holistic ecosystem so as to enable start-ups to experiment their innovative financial products or services within a well defined space and duration. The project aims to support 58 start-ups over a period of 5 years.

IOT OpenLab-a Centre of Excellence (CoE) for Internet of Things at STPI Bengaluru: An IOT OpenLab - a Centre of Excellence (CoE) for Internet of Things in partnership with Arrow Electronics at STPI Bengaluru has been initiated to provide academic and business mentoring of the startups in the IOT emerging technology area for developing products and/ or services around IoT along with networking opportunities for the startups. The IoT OpenLab intends to support and nurture 100 start-ups per year with an overall target to support 500 startups over a period of 5 years.

Centre of Excellence (CoE) on Medi-Electronics & Health Informatics at Lucknow: MeitY has

initiated a Centre of Excellence (CoE) on Medi-Electronics & Health Informatics at Lucknow to stimulate the establishment and growth of technology-based start-ups in the field of medical electronics and health informatics by providing the necessary infrastructure, mentoring, marketing, funding and eco-system required for their success and growth. The Medi-Electronics & Health Informatics CoE is being setup at SGPGI, Lucknow with Department of IT and Electronics, UP Govt. as funding partner, AiMED as industry partner, AMTZ as industry and seed funding partner and Kalam Institute of Health Technology as academic partner. The project aims to support 50 start-ups over a period of 5 years.

ESDM Incubation Centre at Bhubaneswar by STPI: MeitY has approved ESDM Incubation Centre with the objective of creating a holistic eco-system to promote ESDM innovation, R&D and create Indian intellectual property in the Eastern Region of the country. The centre will be operated through STPI, Odisha in collaboration with Government of Odisha, IIIT Bhubaneswar and IESA. It aims to leverage 40 start-ups over the period of 5 years. This eco-system is necessary to develop, promote, incubate, mentor and create breakthrough innovations towards development of product and IP creation in the ESDM sector.

Establishment of Incubator for Electronics Start-ups in Delhi-NCR (Electropreneur Park): The Electropreneur Park established in collaboration with Software Technology Parks of India (STPI), India Electronics & Semiconductor Association (IESA) and Delhi University (DU) with state of the art facilities at South Campus, Delhi University. The project aims to support 50 start-ups. As on date, the Electropreneur Park has supported 26 startups to avail the Incubation facilities at the park out of which 10 are onboard, 8 startups have graduated with 6 currently at revenue stage. As an outcome, 14 new products, 12 working prototypes have been

developed, 18 patents filed, 20 Cr VC/Grants/CSR received by the onboard startups and 196 number of employment generated by the startups.

Electronics Incubator by IIITM-Kerala and KSUM at Cochin, Kerala: The project for setting up of Consumer Electronics Incubator at Cochin, Kerala by Indian Institute of Information Technology and Management Kerala (IIITM-K) and M/s Kerala Startup Mission (KSUM) aims to creation of new enterprises focused on Consumer Electronics through a holistic incubation ecosystem. This incubator will incubate 40 startups over a period of 4 years. Infrastructure setup is completed. Testing and Equipment / IOT, Robotics Lab and Prototyping Room for SMT Assembly Line has been completed. As an outcome, 75 startups have been supported, several products/ working prototypes have been developed, 48 Patents filed out of which 6 patents granted, 17 companies has got its 1st order and 10 crore funding VC/Grants/CSR received to the onboard startups till date.

Setting up of Incubation Centre in the area of ESDM with focus on Medical Electronics at IIT Patna: The incubation facility developed through MeitY and State Government partnership aims to incubate 50 startups over a period of 5 years. The primary objective of this is to promote innovation and entrepreneurship with the aim to identify, nurture and translate technological ideas and innovation in the broad area of ESDM sector with a focus in Medical Electronics. Till date, 37 start-ups have been supported out of which 28 startups are on-board at present including 12 in healthcare and 16 in ESDM sector whereas 5 patents have been filed by the startups.

Fabless chip design incubation centre at IIT Hyderabad: The objective of the fabless chip design incubator is to incubate start-ups in semiconductor design. The vision is to provide one-stop service to start-ups intending to enter this space. This incubator will incubate 50 startups over a period of 5 years. 3 startups have joined the Incubation

Center as well as 3 more Eols have been received.

Industry Innovation Programme on Medical Electronics through BIRAC: With an aim to promote scientific and technological research in medical electronics sector and to address the pressing challenges associated with the development of innovative medical electronics and making it available, accessible and affordable to the people at the bottom of the pyramid, a project has been initiated at Biotechnology Industry Research Assistance Council (BIRAC). Under this program support will be provided at seed or idea to PoC, Early transition and transitions to scale stages. 25 proposals are being supported through BIRAC under the program out of which, 18 proposals are in Idea-to-PoC stage, 5 proposals are in Early Transition stage and 2 proposals are in Transition to Scale stage out of which 2 Products have been launched and 2 IP filed as on date.

Global Innovation and Technology Alliance (GITA): To provide funding and support to Industry and Academic institutions for doing collaborative research to promote Innovation, IP, R&D and commercialization of products etc. in the ESDM sector, a project is being implemented by GITA. For this bilateral programme, Canada, Finland, UK, South Korea, Spain, Israel, Japan, Taiwan and Sweden have been identified. As on date, three projects have been initiated and active under India-Canada (01) and India-UK (02) call for proposals.

5.4 R&D for Cyber Security

Cyber Security R&D is one of major initiatives identified for securing cyber space and it is aimed at promotion of development & technology, demonstration, proof of concept and R&D test bed projects for enhancing indigenous skills and capabilities in the cyber security. Research and development is carried out in the thrust areas of cyber security including (a) cryptography and cryptanalysis, (b) network and system security, (c)

cyber forensics, (d) threat intelligence and AI based threat modelling.

New projects are formulated/initiated in thrust areas identified on continuous basis to enable enhancement of expertise/skills in R&D for cyber security. Accordingly, R&D projects in the area of cyber security have a special focus and emphasis on R&D infrastructure creation, capacity building and enhancement of skills and expertise in the interest of a conducive R&D ecosystem in the country. In addition, specific efforts have been made to nurture institutions and capacity enhancement in the entire North East Region.

Cyber Security R&D Projects

During the year 2019-20, R&D efforts were continued and strengthened. Eleven new projects have been initiated which includes: (i) detecting spoofing and digital attacks on face images, (ii) development of a solution for vulnerability detection in embedded device firmware, (iii) design and development of a solution for predicting multistage attacks using machine learning, (iv) darknet/network Telescope based Cyber Security Monitoring and inference framework, (v) establishment of advanced laboratory for cyber security training in cyber forensics investigation.

Efforts in the on-going projects have resulted in the development of certain indigenous security solutions which are deployed / being deployed at user organisations. These includes: (i) pilot deployment of smart property record management

system at Shamshabad district, Telangana State using block-chain technology, (ii) advance version of cyber forensic tools developed have been provided to various user agencies for their use and necessary training on the use of the tools has also been provided to these user agencies. (iii) setting up of a collaborative and comprehensive live cyber operations specific exercise training facility (Cyber Closet) for Indian cyber space to prepare and enable an organisation to test the systems (critical infrastructure), processes and people against cyber-attacks, (iv) establishing security evaluation, research and exploratory testing centre which will act as a centre of excellence for developing security testing and assessment in response to rapidly evolving cyber threats. The centre will be involved in research to proactively address the most critical security issues across multiple vertical technology products and system in sectors like telecommunications, defense, financial transactions, industrial automation, smart grid, medical electronics etc. with focus on identifying unknown vulnerabilities, (v) setting up of cyber forensic training facility (cyber forensic lab) at National Institute of Criminology and Forensic Science (NICFS), capacity building of NICFS officials in cyber forensics and in use of the developed training facility for R&D and for various training programmes of NICFS and creation of an e-learning system for online training support and access of training materials (vi) development of cyber crime and cyber forensics resource centre for the State of Bihar which will provide cyber forensic

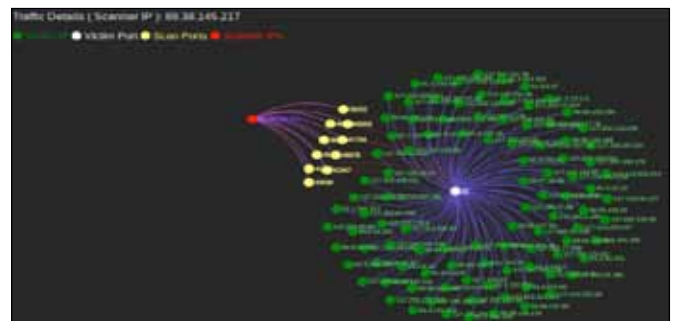

services support to law enforcing agencies and will help in providing broad range of cyber security related training support for different categories of Government and non-Government agencies, (vii) a working prototype system for detecting workload based application layer Distributed Denial of Service (DDoS) attacks on web applications has been developed.

Initiation Setting up of of National Centre of Excellence in Cyber Security

The National Centre of Excellence (CoE) in Cyber Security is being established in collaboration with Data Security Council of India, with an endeavour to build a sustainable cyber security technology and industry development momentum across the country. The major objectives of the Centre are: (i) Building ecosystem of Cyber Security Technology Development and Entrepreneurship (ii) Translating R&D to Security Products (iii) Making Technology Stack of Security Products Contemporary & Cutting Edge and (iv) Market Adoption of Developed Products. The National CoE effort envisages attracting the attention of researchers, start-ups, research institutions, and incubation and acceleration initiatives to the national priorities in the critical areas and sectors like 5G, Internet of Things (IoT) , Block-Chain Technology, Cloud and Virtualization, SCADA/ ICs along with other important areas such as Financial Sector.

The R&D activities in the programme will be carried forward during 2020-21 to promote research and development of indigenous cyber security solutions, proof of concepts and prototypes and skilled manpower in the thrust areas of cyber security with special focus on mobile device security, cloud security and cloud forensics, intelligent traffic analysis, predictive intelligence based on big data analytics, malware detection and advanced cyber forensics.

5.5 R&D for Societal Outreach

5.5.1 Medical Tools, Equipments and Software

- Repair and Maintenance of Medical Electronics Equipment:** Medical Electronics Laboratories have been established at NIELIT, Shillong and NIELIT, Kohima and NIELIT Silchar for repair and maintenance of medical electronic equipment and training of medical and paramedical personnel. Training of 232 candidates (NIELIT, Shillong – 146, NIELIT, Kohima- 74 and Para medical Staff-12) has been completed at these Laboratories.
- Design and Development of 1.5 Tesla Magnetic Resonance Imaging (MRI) Systems:** The objective of the proposed project is to design, develop and test an indigenous 1.5 Tesla MRI System for medical imaging. Magnetic Resonance Imaging (MRI) is a medical imaging technique used in radiology to visualize internal structures of the body with high contrast images. Various subsystems such as image reconstruction, image visualisation, RF systems, RF coil etc have been developed. The coils and software have been integrated with commercial scanner for testing purpose. Software for imaging reconstruction have been developed and integrated. Also IMRI Superconducting Magnet has been designed and its component developed and tested. The IMRI software platform is implemented and modules focusing on scalability, customization, standards compliance and plug-play features are developed.



Fig- Sample Image from Indigenous MRI

- **High energy 30 MeV linear accelerator (LINAC):** The objective of the project is to design & develop 30MeV electron linear accelerator with 5-10kW beam power. The proposed LINAC will generate Molybdenum (Mo-99) which will be used to elute radio isotope Technetium (Tc-99m). The novel Tc-99m radio labelled analogues generated will also be clinically assessed. Various sub system have been designed, fabricated and being tested. Integration of first phase of the system is expected by December 2020.
- **Design & Development of Indigenous Colour Doppler Ultrasound Scanner with centralised PNDT database compliance:** NIELIT, Calicut has developed Lab Model Prototype of Colour Doppler Ultrasound Scanner System with Pre-natal Diagnostic Technique (PNDT) Compliance. The machine has unique ID and any movement of the machine will be automatically tracked with inbuilt GPS facility. The machine also supports Aadhaar based authentication of doctor and patient undergoing scanning. Complete system integration and testing is under progress.

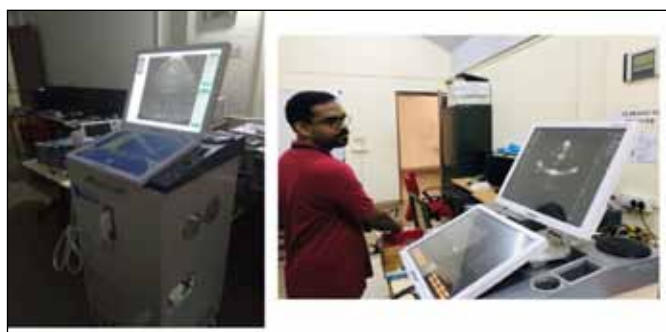

Fig- Indigenous Colour Doppler Ultrasound System (Lab Model)

- **Studies on detection of cancer, processing infrared images and developing appropriate instrumentation system for initial deployment in N.E. States:** The IR based breast Cancer detection system

named “The Karkat Nirnay Yantra” has been developed and handed over to Cachar Cancer Hospital and Research Centre, Silchar and system is in operation. A system for IR Based Breast Cancer Detection has been awarded from DG, CDAC for excellence in Core Research Category by CDAC on 15th August, 2019. Validation has shown accuracy more than 87% so far which is satisfactory from doctors’ point of view.



Fig-Karkat Nirnay Yantra-IR based cancer Detection System

- **Certification Schemes for Compliance with EHR Standards:** This project will make it possible to implement standardized Electronic Health Record at National/State level for e-Governance in Health Care Sector. It will also help public and private healthcare operators to become compliant to notified EHR standards of Ministry of Health & Family Welfare. Towards certification of EHR standards compliance, C-DAC in collaboration with STQC has developed techniques, methodologies, and tools for evaluation, test engineering and related technology for evaluation and certification of EHR related systems. STQC is the process to launch EHR Certification scheme.
- **Maxillo-Facial Surgery Planning and Simulation System:** A reliable planning and simulation system for maxillo-facial surgery which enables precise 2D cephalometric

analysis and interactive manipulations of 3D reconstructions of the facial tissue in order to visualize the patient's post operative appearance is being developed. CDAC team alongwith AIIMS has developed an initial integrated version of the application Integrated 3D simulation module into the GUI application. This technique has ability to generate a 3D picture of pre and post-surgical appearance of a patient which would be helpful for decision making for the patient as well as the surgeon. Simulation software is completed and the validation/review is in progress. The software can accept both 2D cephalometry images obtained from CT / CBCT scanners and 2D slices of images

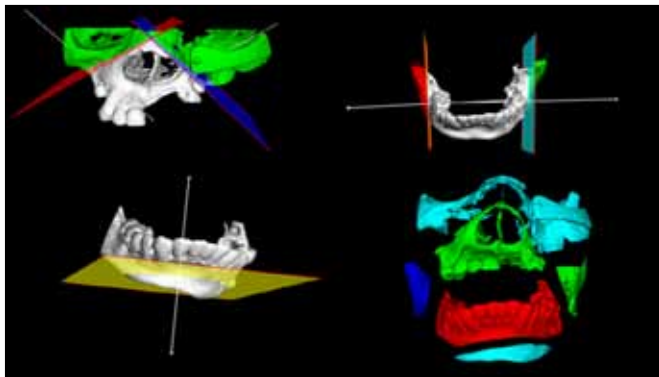

Fig- 2D Images obtained from Maxillo-Facial Surgery Planning and Simulation Tool

- Development of Thermal Tomography for the Detection of breast cancer and to predict the Size and Location of the Cancerous Tissue:** The main objective of the project is to develop an analysis system for accurate prediction of human breast abnormality using thermal tomography. C-MET has developed a wearable jacket using high sensitivity thermal sensors for the early detection and screening of breast cancer along with 2D analysis system which works on open source platform. C-MET is further improvising on the S/W to

develop 3D thermal tomography for finding out location and size of the cancerous tissue. Bio heat transfer based 3D thermal modelling of human breast has been developed.

- Development of Low Cost Automated Screening System for Cervical Cancer (CerviSCAN-II):** The aim of the project is to develop a low cost and an economically viable system for primary screening of cervical cancer which is the most prevalent cancer among women in India. C-DAC is focusing on the indigenous development of medical equipments - automated slide digitizer, cyto centrifuge and automated slide stainer in this project. The project also involves development of indigenised PAP smear preparation method called Mega Funnel Technique (MFT) developed.

5.5.2 Agriculture

5.5.2.1 Smart Warehouses Technology

The technology development and deployment have been completed for safe storage of rice grains. The development includes sub-systems like Conveyorized System with On-line identification of bags, Moisture Measurement, RF disinfection, Fumigation, measurement of concentration of gases etc. The temperature and humidity of the warehouse are measured and controlled in real time through central controller. A quality assessment system, Annadarpan has also been incorporated in the system to record the quality parameter of grains. Entire system and sub-systems have been developed, calibrated and commissioned at the godowns at Food Corporation of India (FCI) at Raipur. This has shown benefits like safe storage of food grains etc. for a longer period. Through an awareness programme technology has been propagated to miller, farmers and FCI officials etc.

5.5.2.2 Design and Development of Automated Aquaponics System for Vertical Farming in India

This project has been initiated with an aim to design, development and deployment of Automated Aquaponic system with real time monitoring and control of, Electrical Conductivity (EC) and other nutrient in solution for vertical farming. In this project, a new method of farming is being investigated which require less land and water but provide high yield. The Layout of the whole system and sub-system like layout of green house, water flow, cooling system, vertical stacking and the electronic system have been finalized and civil work has also been completed.

5.5.2.3 Development of Autonomous Multipurpose Agricultural Robotic Platform

The aim of the project is to design and develop a battery powered / Hybrid (Fuel and battery based) autonomous Multipurpose Field Robotic Platform (MFRP) to carry out activities like Sowing of seeds using direct seeding technique, spraying of

pesticides, weedicides and fertilizers, monitoring of crop health for further usage, development of Human Machine Interface (HMI). Selection of sensors, mechanical components, development platform, etc. has been completed and the scaled down version of the robot is under development for testing the controllers and other algorithms. The assembly of the scaled down version of the robot is under progress.

5.5.2.4 Electronic Waste Awareness Programme

Ministry of Electronics & Information Technology (MeitY) is implementing an “Awareness Programme on Environmental Hazards of Electronic Waste” since 2015 to create awareness among the public about the hazards of e-waste recycling in informal sector on Pan India basis. The programme has created training tools, content materials, films, printed materials, videos and jingles etc. for every stratum of the society which are freely available on the dedicated website (www.greene.gov.in) and Greene app. Further, social media platforms (Twitter



handle, Facebook page, youtube channel) have also been created to provide online status of the activities and show-case the activities/ workshops/ carnivals etc. of the programme. So far, 31 States/ UTs have been covered and 1923 workshops and activities have been conducted to cover nearly 13.27 lakhs participants including school, colleges, RWA, manufacturer, informal operators etc. and 1247 GreenE champions were created. This programme has also trained 5789 Government officials through 1750 training programmes. Mass awareness amongst youth of the country has also been created through 2813 cinema halls to reach nearly 20.11 crore audience. Attempts to develop suitable course content for the SWAYAM digital platform for Standard 7 to 9 class students are in progress.

5.5.2.5 Entrepreneurial Training Programme for Scheduled Caste Communities in Kerala

An entrepreneurship program has been initiated through CMET for upliftment of Scheduled Caste (SC) Communities by providing technical training and manufacturing kit for production of indigenous sensor based digital thermometers. The program is a joint collaborative effort between Government of India through CMET and State Government of Kerala through Institute of Human Resource Development (IHRD), Kochi and envisages training of 300 persons from SC communities.



Entrepreneurial Training Programme for Scheduled Tribe Communities in Kerala

An entrepreneurship program has been initiated through CMET for up upliftment of Scheduled

Tribe (ST) Communities by providing technical training and manufacturing kit for production of indigenous supercapacitors based Solar Lanterns/ LED bulbs. The program is a joint collaborative effort between Government of India through CMET and State Government of Kerala through Institute of Human Resource Development (IHRD), Kochi and envisages training of 300 persons from SC communities.



5.5.3 Healthcare

Nanotechnology Initiatives

5.5.3.1 Point-of-Care-Testing Device for Fingerprint Bilirubin Detection at IIT Guwahati

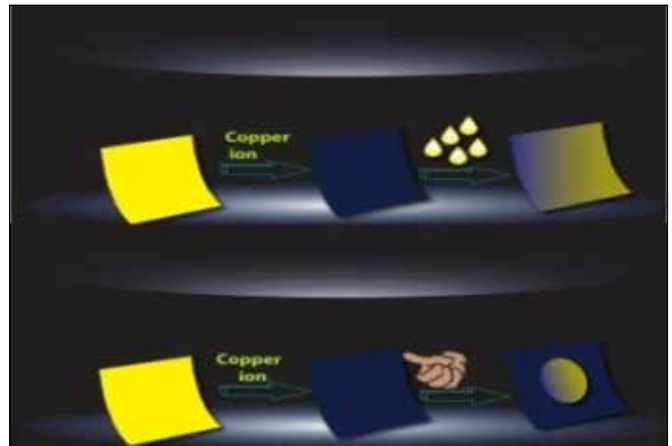

A diagnostic device or kit for visual detection of bilirubin has been fabricated at IIT Guwahati. The said device enables non-invasive detection of hyperbilirubinemia by thumb impression visually or from blood serum.

5.5.3.2 Point-of-Care-Testing Device for Pancreatic Amylase Detection and to determine Albumin to Creatinine Ratio at IIT Guwahati



The simple, single step, cost-effective easily disposable system /kit is useful for point-of-care detection of a host of important biomarkers such as amylase, creatinine, or albumin, among others.

A transmittance based system /kit for point-of-care quantification of biomarker samples is comprised of: a stage supporting a detection unit, an optical transmittance unit, and a signal processing unit. The detection unit i.e. reactive substrate is capable of undergoing a specific biomarker sample interactive reaction and generating a quantifiable optical signal proportional to the concentration of the said biomarker sample wherein the intensity of the color varies with the concentration of the analyte in the bio-sample.

5.5.3.3 Point-of-Care-Testing Device for Lung Condition Monitoring at IIT Guwahati

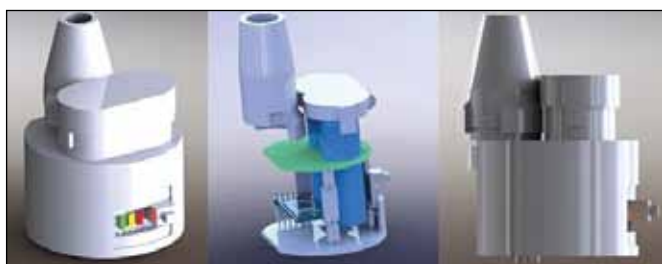

The Lung condition monitoring device comprises a mouthpiece for forcibly exhaling air there through, one or more humidity sensor to measure the variable electrical resistance based on level of adsorption of water molecules thereon of the humidity content of exhaled air and real time monitoring unit operatively connected to said humidity sensor and having

correlating means for correlating the change in humidity level and related variation in the electrical resistance due to exhalation to peak flow rate of the exhaled air for monitoring lung condition.

5.5.3.4 Point-of-Care-Testing Device for Parkinson's Patients at IIT Guwahati

The developed POCT device has the capability to detect the neurological disorders at the mature as well as at the early stages with the vision of control and prevention of these diseases. This device is composed of a detection unit, a flexible pressure sensor, a signal processing unit, and a power supply. The detection unit is composed of the sensor and press-knob. The electrical circuits in the signal processing unit are laid down in such a manner that the magnitude of this output current varies with the tremor between the fingers, which eventually converted into an electrical signal showing the variation in the hand tremor with time.

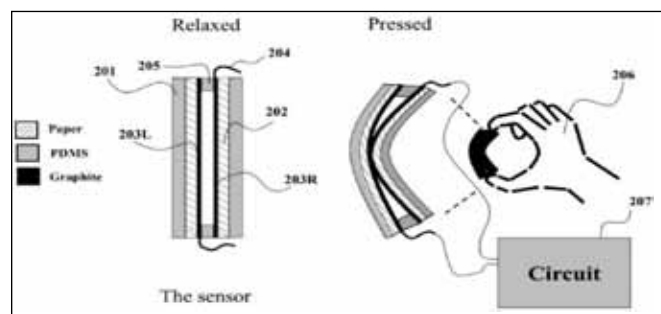

5.5.4 Societal Miscellaneous

5.5.4.1 Collaborative Intelligent Transportation Systems Endeavour for Indian Cities

The aim of the project is Indigenous technology/product development in the areas of Intelligent Transportation System (ITS). The major component of ITS covered for investigation include the Traffic Simulator, Integrated 3D Driving Simulator, Development of V2X for Better Mobility, Data-driven Models and Decision Support Tools for Advanced Public Transportation Systems (APTS) in Indian Cities, Smart Vision Sensors for Industrial and

Road traffic applications, Command, Control and Management Software for Intelligent Transportation Systems (ITS) with Common Service Layer based on Global Protocol, Bus Priority System at Signalized Intersection and Promotion of Road Safety through Deployment of Driver Assistance and Warning system etc. The Design, development and assembling of vehicle mount unit and preliminary plans for vehicle test runs have been completed. Fabrication work on mmWave radar is in progress. The specifications and requirement for other sub-system have been finalized.

5.5.4.2 Automated Machine Vision System for Leather Surface Quality Discriminant Function Analysis

The development of an integrated online machine vision based inspection system for detection and classification of defects in finished leather is progressing at CEERI, Chennai. The XY table has been fabricated and commissioned; the corresponding software using open source is under development. The large number of defects have been collected digitally using an arrangement of Camera etc.



XY table for leather image collection

5.5.4.3 Design and development of Anti-Eve Teasing Device for Women Safety”

A proof of concept for development of a wearable women safety device to provide safety instantly is being explored at NIT-Jalandhar. The technology is unique in nature as it could provide safety to women in case of distress without needing the

physical help from others. The requirement and specifications have been finalized. The first version of prototype has been developed and being tested in laboratory.



Prototype of anti-eve-teasing device

5.5.4.4 Implementation of Distributed Automation System for state-owned Electrical Substations in North Sikkim

The implementation of ASTeC products, a state-of-the art configurable Automation System, in the Electrical distribution Substations located at Maltin, Lachung and Rabom is progressing. These substations belongs to Energy and Power Department (EPD), Govt. of Sikkim. The substation i.e. Maltin and Lachung have been provided with the automation system and installation, commissioning and testing at Rabom and integrated control for all three stations is in progress.

5.5.4.5 Enhancement, Field Testing, Training and Maintenance of DigiBunai™ (Open Source CAD Tool for Weaving)

The enhancement of the DigiBunai™ (Computer Aided Textile Designing Tool) application for garments like scarf, stole and dress material with better user interface, along with multi layered cloth, extra warp, electronic jacquard support and support for other weaving technique (such as Ikat) is progressing. The DPR and development of the feature showcasing all the possible color combination of warp and weft for colorways has been completed. Data import/export modules is under testing with central server.

5.5.5 Information Technology Research Academy (ITRA)

ITRA, is an enabling programme initiated by Ministry of Electronics and IT (MeitY), Government of India to help build a national resource for advancing the quality & quantity of R&D in Information and Communications Technologies and Electronics (IT for brevity) and its applications in IT and related institutions across India. ITRA is operating as a division of Digital India Corporation (DIC).

Over the duration of ITRA, cumulative achievements under the multi-institutional consortium mode R&D projects in the areas, viz. (i) “*Mobile Computing, Networking and Applications (ITRA-Mobile)*”; (ii) “*IT based Innovations in Water Resources Sustainability (ITRA-Water)*”; and, (ii) “*IT based Transformations in Indian Agriculture and Food (ITRA-Ag&Food)*” implemented, 21 prototype

technologies/ services with potential startup possibilities are being pursued. 143 faculty members and 73 research students from about 60 academic institutions participated in various research projects of ITRA. 383 ITRA acknowledged research papers have been published under ITRA research. 11 patents and 2 copyrights filed under the project.

During 2019-20 the highlights of ITRA activities are as follows:

- a. ITRA Technology Showcase was organized on July 23, 2019 at MeitY. It was attended by various stakeholders from Govt. Departments and user agencies. The event was organized to present the potential and value of the technologies to the participants and to get their comments and feedback.



ITRA-Exhibition

ITRA-User Interactions



Chapter – 6

Internet Governance and Security of Cyber Space



6.1 Internet Governance

Overview:

Internet Governance, broadly defined, is the development and application by Governments, the private sector and civil society, in their respective roles, of shared principles, norms, rules, decision making procedures and programmes that shape the evolution and use of the internet. It includes development and coordination of technical standards, operation of critical infrastructure and public policy issues.

Conceptually Internet Governance includes following layers

- Physical Infrastructure Layer
- Code or logical layer
- Content layer
- Security layer

Internet Governance involves IP addressing, Domain Name System(DNS), Routing, Technical Innovations, Standardizations, Security, Public Policy, Privacy, Legal Issues, Cyber Norms, issues pertaining to Intellectual properties and taxation.

6.1.1 Achievements:

Some of the significant achievements of MeitY include representation of India's Public Policy concerns on global platforms, creating awareness on Internet Governance, encouraging greater participation in Internet Engineering Task Force (IETF) working groups, engagement with Internet Society (ISOC) promotion of Multistakeholder model of Internet Governance in India etc.

6.1.1.1 Engagement in International Forums/ Meetings:

Engagement with Internet Corporation for Assigned Names & Numbers (ICANN) : Meity

is actively involved with the activity of ICANN and participants in its proceedings through Government Advisory Committee (GAC) and other public engagement fora. The GAC's key role is to advise ICANN on issues of public policy and especially where there may be an interaction between ICANN's activities or policies and national laws of international agreements. Indian Government comments on various international forums/discussion can be accessed at www.indiaig.in

- **IGF- the Internet Governance Forum :** serves to bring people together from various stakeholder groups as equals, in discussions on public policy issues relating to the internet. India's concerns on the issues of public policy of the internet and its governance are appropriately voiced in meetings of the IGF through regular participation, multi-lateral and bi-lateral meetings. With the renewal of its mandate by United Nations in December 2015, the IGF consolidates itself as platform, to bring people together from various stakeholders groups as equals. While there is no negotiated outcome, the IGF informs and inspires those with policy making power in both the public and private sector at their annual meetings, delegates discuss, exchange information and share good practices with each other. The IGF facilitates a common understanding on how to maximize internet opportunities and address risks and challenges that may arise.
- **Multi stakeholder consultations:** India Supports Multistakeholder model of Internet Governance, which would involve all stakeholders and helps to preserve the character of the internet as unified, dynamic engine for innovation and which encourage equity and innovation.
- **Guidelines for allocation of registration at the third level under .GOV.IN domain zone:** Guidelines for allocation of domains

under .GOV.IN were issued by MeitY on 06.04.2015. The above guidelines has been revised, in order to incorporate the experience gained during the past as well as to cater to the growing future requirements, given the rapid growth in the numbers of new schemes and programmes being launched by the Government of India from time to time. Accordingly, the revised Guidelines for allocation of registration at the third level under .GOV.IN domain zone has been issued on 23.10.2019.

- Framework and Guidelines for deregistration of .IN Domains in case of complaints received from Government Authorities where the websites/ domains are being used fraudulently to pass off as similar.GOV.IN websites/ Domains.

6.1.1.2 The Research, Development and awareness agenda that have been undertaken in the area of Internet Governance include:

Projects under internet Governance Division:

An Ecosystem for Active participation in Internet Standard organizations implemented by Centre for Development of Advanced Computing (C-DAC), Bengaluru.

- The primary objective is to get involved in the process of Internet Standard development by developing internal competencies in order to propose and contribute to select areas of internet security.
- Create and foster focus groups to work on specific technical issues of interest concerning Internet Standards, propose new standards and contribute to ongoing drafts in areas related to internet security.
- Encouraging direct participation in the meetings of the Internet Organizations.

- Engage with academic community (students and faculty), industry and civil society in order to promote their participation in Internet Organizations.
- Awarding scholarships and fellowships to deserving candidates in order to encourage participation in IETF activities and to prepare for hosting IETF or similar meetings, in India, in future.
- Implementing agency is contributing on ongoing drafts - tls, uta, tokbind, ace, oauth, secevent and initiating new draft - Digital Tokens.
- Awareness programmes have been conducted, expert meetings were organized and IIREF (Indian Internet Research and Engineering Forum) established.
- 12 Fellowships have been awarded to attend IETF meetings.
- ICIRE 2019 (International Conference on Internet Research and Engineering) was held on 3rd and 4th March 2019.

Advanced Internet Operations Research in India (AIORI) by Software Technology Parks of India (STPI).

Project seeks to improve the security, stability, and understanding of the Internet’s DNS infrastructure in India by advanced Internet Operations research and it plans to do so by:

- Building relationships among its community of members and facilitate an environment where information can be shared confidentially.
- Enabling knowledge transfer by organizing workshop.
- Research with operational relevance through data collection and analysis.
- Increasing awareness of the DNS’s significance.

- Offer useful, publicly available tools and services.

Stakeholder consultation is being done. Anchor Design has been completed.

IG SIM- Internet Governance Structured Implementation Module by C-DAC, Delhi.

The objective of the project & envisages, providing technical and policy support to conduct of research, training workshops and preparation of white paper, technology reports on various Internet Governance policy and Technology related issues. This will include providing ongoing implementation support to IG related activities of the Government of India, Ministry of Electronics and Information Technology (MeitY) and review the global Internet policy and Technology landscape and provide assistant w.r.t. structured implementation on matters related to Internet Governance, taking into account rapid technical developments and dynamically changing needs.

Promotion of Universal Acceptance for India for Internet in India- for Devangari Script by Internet & Mobile Association of India (IAMI)

The major objectives is to reach out to the Internet businesses, developers and startup community to create awareness about the critically of Universal Acceptance (UA) and the technical solutions being developed and to facilitate integration of Indian script in the internet via UA, thereby helping provide internet content in Indian local languages that in turn will enable greater internet penetration and usage in the country. 5 Workshop have already been conducted at various locations.

MeitY Chair for Internet policy: Value, Security and Governance implemented by Indian Council for Research on International economic Relations (ICRIER)

The objective is to provide MeitY with evidence based research that will build capacity for India’s

participation in multiple international fora, while strengthening domestic policy. The research and related activities will be conducted under three broad themes that are as follows:

- a. Assessing the value generated by the internet
- b. Enabling a secure and open internet
- c. Developing a framework for internet governance

A research paper on data flows and data localization: An Economic Analysis and a policy brief on .in ccTLD is completed & under internal review Research paper on India's Domain Name Market is being prepared. Research paper on 'Bridging the Digital Divide: Barriers to Adoption and Usage' and Policy Brief on 'IPv6 transition' have been completed.

6.2 National Internet Exchange of India (NIXI)

NIXI is a not for profit organization set up under section 25 of the Companies Act, 1956 (now section 8 under Companies Act, 2013) for peering of ISPs among themselves and routing the domestic traffic within the country, with seed funding from Ministry of Electronics & Information Technology. NIXI is performing the following three activities.

- Internet Exchange
- IN Registry and Internationalised Domain Names (IDNs)
- National Internet Registry (NIR)

Internet Exchange: Eight Internet Exchange Nodes are functional at Delhi (Noida), Mumbai, Chennai, Kolkata, Bengaluru, Hyderabad, Ahmedabad and Guwahati. The Internet Exchange nodes have been successful in ensuring peering of ISPs among themselves for the purpose of routing the domestic traffic within the country, instead of taking abroad, thereby resulting in better quality of service (reduced latency) and reduced bandwidth charges for ISPs by saving on International

Bandwidth. The maximum volume of Internet traffic being handled by NIXI at present is 150 Gbps.

All functional NIXI nodes are IPv6 ready. NIXI also undertakes training and workshop for Network managers and other Technical engineers in co-operation with Asia Pacific Network Information Centre (APNIC).

IN Registry and Internationalised Domain Names (IDNs): Since 2005, NIXI also manages the .IN Registry (www.registry.in). At present, 132 Registrars have been accredited to offer .IN domain name registration worldwide to customers. This has helped proliferation of web hosting in the country and promotion of Indian language content on the Internet. Over 20.50 lakhs .IN Domain names have been registered till October 2019.

IDN's in Hindi, Bodo, Dogri, Konkani, Maithili, Marathi, Nepali Sindhi, Bangali, Gujarati, Manipuri, Punjabi, Tamil, Telugu and Urdu languages were launched during the year 2014-15 and over 10000 IDNs domain names have been registered till date. NIXI is now ready to launch IDNs in all remaining languages (Assamese, Kannada, Malayalam, Oriya, Sanskrit, and Santali in Devanagari Script and Kashmiri & Sindhi in Perso-Arabic Script). With this IDNs in all 22 official languages will be available.

National Internet Registry (NIR): Since March, 2012 NIXI is also running the National Internet Registry (NIR) for India named as Indian Registry for Internet Names and Numbers (IRINN). IRINN is responsible for allocation of IP addresses and AS Numbers within the country. As on October 2019 over 2820 affiliates have joined IRINN. Out of 2820 Affiliates, 556 affiliates have taken IPv6 as well as IPv4.

6.3 Security of Cyber Space

Cyberspace refers to the virtual computer world and more specifically, is an electronic medium used to

form a global computer network to facilitate online communication and dissemination of information. It is a complex environment of people, software, hardware and internet. Today, cyberspace is the common platform being used by citizens, civil society, businesses and Governments for communication and dissemination of information online. Since the cyberspace is virtual, borderless and offers complete anonymity, as a result, attacks can be launched from anywhere in the world with limited possibility of trace back and positive attribution.

Cyberspace has been facing many security challenges due to emerging cyber threats and its widespread use for social media and e-transactions. As countermeasures, Government of India has taken several legal, technical and administrative policy measures for addressing cyber security. This includes National Cyber Security policy (2013), framework for enhancing Cyber Security (2013), enactment of Information Technology (IT) Act, 2000 and setting up of Indian Computer Emergency Response Team (CERT-In) for 24x7 cyber incident response, and National Critical Information Infrastructure Protection Centre (NCIIPC) for protection of critical information infrastructure under the IT Act, 2000, Cyber Security Research & Development (R&D) and Capacity Building in cyber security.

6.3.1 Cyber Law

Comprehensive legal framework in terms of IT Act 2000 and its amendment provides for:

- Collection and sharing of information related to cyber incidents (sections 69B & 70B) for effective proactive/reactive actions by CERT-In and investigative actions by law enforcement agencies
- Prescription and implementation of security best practices and guidelines to prevent occurrence and recurrence of security incidents (section 43A & 70B)

- Protection of critical information infrastructure (section 70A)
- Effective deterrence provisions (sections 43, 43A, 66, 66B, 66C, 66D, 66E, 66F, 67, 67A, 67B, 72 & 72A) in terms of compensation/penalty and punishment to deal with cyber crimes such as damage to computer system, computer related offences, sensitive personal data leak, identity theft, cheating by personation, violation of privacy, cyber terrorism, online pornography including child pornography, breach of confidentiality and privacy, breach of lawful contract etc.

6.3.2 National Cyber Security Policy

National Cyber Security Policy was released for public use in July 2013. The Policy caters to the cyber security requirements of Government and non-Government entities as well as large, medium & small enterprises and home users. The policy recognises the need for objectives and strategies that need to be adopted both at the national level as well as international level. The policy aims at facilitating creation of secure computing environment and enabling adequate trust and confidence in electronic transactions and also guiding stakeholders' actions for protection of cyber space. Considering the developments in cyber technology, delivery of services through cyber space and the changing nature of cyber threats over the years, Government of India has initiated the development of National Cyber Security Strategy 2020, which will enhance objective and implementation of National Cyber Security Policy.

6.3.3 Indian Computer Emergency Response Team (CERT-In)

The Indian Computer Emergency Response Team (CERT-In) is a statutory organisation under Ministry of Electronics and Information Technology, Government of India. CERT-In has been designated

under Section 70B of the Information Technology Act, 2000 to serve as the national agency to perform the following functions in the area of cyber security:

- Collection, analysis and dissemination of information on cyber security incidents
- Forecast and alerts of cyber security incidents
- Emergency measures for handling cyber security incidents
- Coordination of cyber security incident response activities
- Issue guidelines, advisories, vulnerability notes and white papers relating to information security practices, procedures, prevention, response and reporting of cyber incidents
- Such other functions relating to cyber security as may be prescribed.

CERT-In creates awareness on security issues through dissemination of information on its website (<http://www.cert-in.org.in>) and operates 24x7 incidence response Help Desk. CERT-In provides Incident Prevention and Response services as well as Security Quality Management Services. The activities carried out by CERT-In during April 2019-October 2019 comprised of the following:

Activities	Numbers (April 2019 – December 2019)
Incidents handled	328490
Security Alerts	162
Advisories	26
Vulnerability Notes	151
Trainings	21
Indian Website Defacement	14491
International Security Drills	5

Cyber Security Assurance

Under Security Assurance Framework, Indian Computer Emergency Response Team (CERT-In) has created a panel of 'IT security auditing organisations' for auditing, including vulnerability assessment and penetration testing of computer systems, networks & applications of various organizations of the Government, critical infrastructure organizations and those in other sectors of Indian economy. CERT-In has empanelled 90 Information Security Auditing organisations, on the basis of stringent qualifying criteria, to carry out information security audit, including the vulnerability assessment and penetration test of the networked infrastructure of Government and critical sector organisations. This list of CERT-In empanelled auditing organisations are being consulted frequently by the entities in Government and critical sectors for their auditing requirements.

Cyber Crisis Management Plan

CERT-In, MeitY has formulated Cyber Crisis Management Plan (CCMP)-2019 for countering cyber attacks and cyber terrorism for implementation by all Ministries/Departments of Central Government, State Governments/UTs and organizations under their administrative control. Along with the CCMP-2019, CERT-In has developed for first time "Guidance Framework for CCMP" which may be used as a template by various entities including Central Government Ministries/Departments/States/UTs and entities under their administrative control to prepare & implement their own CCMP. "Cyber Crisis Management Plan -2019" and "Guidance Framework for CCMP" were circulated to all Central Government Ministries/Departments and States/UTs to enable them to develop and implement their own CCMP. CCMP outlines a framework for dealing with cyber related incidents for a coordinated, multi-disciplinary and broad based approach for rapid identification, information exchange, swift response and remedial

actions to mitigate and recover from malicious cyber incidents. CERT-In has conducted four workshops since April- 2019 to appraise various organizations under the Central Ministries/States/UTs about the CCMP implementation and all necessary assistance is being provided to them with regard to implementation of CCMP. Till date, 76 CCMP enabling workshops have been conducted.

Cyber Security Exercises

Indian Cyber Crisis Exercises (ICCE)

Indian Cyber Crisis Exercises (ICCE) are being conducted by the Government to help the organisations to assess their preparedness to withstand cyber-attacks. These exercises have helped tremendously in improving the cyber security posture of the information infrastructure and training of manpower to handle cyber incidents, besides increasing the cyber security awareness among the key sector organisations. Till date CERT-In has conducted 44 Cyber security exercises of different complexities, including table top exercises, with participation from about 300 organisations covering various sectors of Indian economy from Government/Public/ Private i.e. Defence, Paramilitary forces, Space, Atomic Energy, Telecommunications (ISPs), Finance, Power, Oil & Natural Gas, Transportation (Railways & Civil Aviation), IT/ ITeS/ BPO sectors and State Data Centres. A total of three cyber security exercises including Table Top Exercises have been conducted by CERT-In during the period April-2019 to October-2019 to enhance the preparedness of participants in handling cyber security threats. Out of these three cyber security exercises, one was Indian Cyber Crisis Exercise (ICCE) carried out by CERT-In for Cooperative banks on 31st May 2019. The other two cyber security exercises were table top exercises out of which one was Joint Cyber Security exercise along with RBI on 30th May, 2019 for various commercial banks to enable them to assess their emergency incident response

preparedness and the second was Cyber Crisis Table Top Exercise for State Government officials of Assam on 22nd & 23rd July 2019.

International Cyber Security Exercises

CERT-In participated in the APCERT drill 2019 on 31st July 2019 which was conducted with the objective to test the response capability of leading Computer Security Incident Response Teams (CSIRT) within the Asia Pacific economies. The theme of this year's APCERT Drill was "Catastrophic Silent Draining in Enterprise Network."

CERT-In participated in ASEAN CERTs Incident Response Drill (ACID), 2019 which was conducted on 4th September 2019, with the objectives of strengthening cyber security preparedness of ASEAN member States and Dialogue partners in handling cyber incidents and reinforce regional coordination drills to test incident response capabilities. This year the theme of the drill was "Combat Evolving Cyber Threats with Good Cyber Hygiene"

CERT-In participated in "Organization of The Islamic Cooperation – Computer Emergency Response Teams (OIC-CERT) Drill" on 17th September 2019. This year theme of the exercise was 'The Rise of Malware Intelligence'.

Ethiopia Table Top Exercise: CERT-In conducted a multilateral table top exercise in Addis Ababa, Ethiopia. There were over 70 participants in this workshop from across the African union, developed and developing countries as well as the industry and academia. The theme of the exercise was incident response in a cross-sector and cross-border scenario.

Cyber Swachhta Kendra (Botnet Cleaning and Malware Analysis Centre)

The "Cyber Swachhta Kendra" is operated by the Indian Computer Emergency Response Team (CERT-In) as part of the Government of

India's Digital India initiative under the Ministry of Electronics and Information Technology (MeitY). The Cyber Swachhta Kendra (CSK) which was launched on 21 February 2017 is a citizen centric service provided by CERT-In, which extends the Hon'ble Prime Minister's vision of Swachh Bharat to the Cyber Space. Its goal is to create a secure cyber space by detecting botnet infections in India and to notify, enable cleaning and securing systems of end users, so as to prevent further infections. By providing free tools and security best practices for citizens the Cyber Swachhta Kendra helps users to securely carry out digital payments, secure their personal computers, broadband routers, mobile phones etc. thereby enhancing citizens trust in ICT while ensuring a cleaner and safer Digital India. At present, CSK is covering 94% of the subscriber base for notifications on botnet/malware infection systems.

Currently, 214 organizations from multiple sectors like Telecom (ISPs), Finance and Insurance, Stocks, Transport, Power, Academia, Government and Oil & Gas are also collaborating and being benefited by using CSK services.

During the year 2018-19 (January 2018 – October 2019), 516 types of botnet/malware were tracked and reported to collaborating ISPs/organizations. Malware/Botnet infections include Bots affecting desktop systems, IoT bots, Ransomware, cryptocurrency miners, information stealing Trojans, banking trojans etc.

Free Bot Removal Tool (FBRT) is being regularly updated with signatures/detections for recent botnet/malware observed to enable cleaning of infected systems. A Total of 10.5 Lakh numbers of Free Bot Removal Tool (FBRT) downloaded till October 2019. Further, systems with vulnerable services were tracked and reported to organizations along with remedial measures.

“Cyber Swachhta Kendra” was awarded as one of 51 “Gems of Digital India 2018” in June 2018.

“Cyber Swachhta Kendra” was also awarded “SKOCH Order-of-Merit and Gold Award” for Cost Effective Cyber Security Model in the month of December 2018.

CERT-In and its project “Cyber Swachhta Kendra” awarded for “Special Recognition in Cyber Security” in CISO MAG AWARDS INDIA 2019.

CERT-In Threat Intelligence eXchange-Proactive Threat Intelligence Sharing Platform

CERT-In Threat Intel eXchange (CTIX) equips the stakeholder analysts with format agnostic, real-time, reliable, verified tactical threat intelligence based on the industry and location of the organization. CTIX facilitates bidirectional sharing of enriched tactical threat intelligence thus helping to build a cyber-resilient ecosystem. The main goal of CERT-In is to collect, analyse and disseminate cyber threat intelligence in real time. The exchange of CTI represented in STIX (Structured Threat Information expression) is communicated through TAXII (Trusted Automated Exchange of Intelligence Information) protocol over HTTPS.

The information shared as CTI by CERT-In assists in the technical, operational, tactical and strategic defence of network-based assets.

The goals of CTIX are:

- Enable timely and secure sharing of threat information by CERT-In, in cyber defender communities in Indian Cyber Space and International Trust Partners.
- Enable organization to anonymously share intelligence back with CERT-In
- Emerge as a Centre of Excellence in Cyber threat intelligence and acts as National Cyber threat Intelligence Data Store for various stakeholders to collaborate and share.

CERT-In via CTIX distributed details to its constituency regarding 14 malicious campaigns, recommended 5 course of action, provided details

of 126 threat actors, made available facts related to 42,089 malicious domains, 6,17 lakh malicious IPs, 35,043 malicious URLs and 539 vulnerabilities being exploited by malicious actors.

Cooperation and Collaboration

Strengthening cooperation with all stakeholders to effectively deal with cyber security issues has been one of the main focus areas of the Government. As such, this aspect is being dealt with by way of security cooperation arrangements in the form of Memorandum of Understanding (MoU) between Indian Computer Emergency Response Team (CERT-In) and its overseas counterpart agencies, that are willing to work together and share information in a timely manner for preventing cyber attacks as well as collaborating for providing swift response to such incidents. At present such MoUs have been signed with counterpart agencies / CERTs of United States of America (USA), United Kingdom, Japan, South Korea, Australia, Malaysia, Singapore, Canada, Vietnam, Uzbekistan, Bangladesh, Seychelles, Kingdom of Morocco, Finland and Estonia.

CERT-In is regularly coordinating with leading service providers and product vendors within and outside the country to obtain advance information on latest cyber threats and attack trends and devise appropriate proactive and preventive measures.

CERT-In is an operational member of Asia Pacific Computer Emergency Response Teams (APCERT). CERT-In is the convener of two working groups across APCERT namely “IoT Security working group” and “Secure Digital Payments working group” to address security threats and evolve best practices to secure these domains. The first report of the “Secure Digital Payments” working group was completed and circulated to the APCERT operational members.

CERT-In is also member of various other working groups under APCERT such as Information sharing

working group, Drill working group, Malware Mitigation working group, Training Working Group and Tsubame Working Group, Forum of Incident Response and Security Teams (FIRST) & Global Research Partner Anti Phishing Working Group (APWG).

Upgradation of Infrastructure

DNS servers have been upgraded with latest hardware and security features. With the increase in user data base and need of more storage space due to enhanced applications and users the storage area network has been augmented with the latest flash technology which has reduced the response time and increased storage capacity. Additional security equipment have been integrated with the unified threats management system to handle malicious zero day attacks. UTM and intrusion prevention equipment at the disaster recovery site have been upgraded in order to handle the increase volume of traffic. Automated scanning tools have been deployed in the local area Network to keep the active nodes free from virus and malware.

Security awareness, skill development and training

In order to create security awareness within the government, public and critical sector organisations, CERT-In regularly conducts trainings/workshops to train officials of Government, critical sector, public sector industry, financial & banking sector on various contemporary and focused topics of cyber security. During the period April 2019- October 2019, CERT-In has conducted 19 trainings (including a separate training programme for women IT officers) on various specialized topics of cyber security. 515 officers including system/Network Administrators, Database Administrators, Application developers, IT Managers, Chief Information Security Officers (CISOs)/ Chief information officers (CIOs), and IT Security professional have been trained.

Cyber Forensics

Cyber Forensics Lab at CERT-In is equipped with the equipment and tools to carry out processing and analysis of the raw data extracted from the digital data storage and mobile devices using sound digital forensic techniques. The primary task of the lab is to assist the Incident Response (IR) team of CERT-In on occurrence of a cyber incident and extend digital forensic support. In addition, Cyber Forensics Lab is being utilised in investigation of the cases of cyber security incidents and cyber crimes, submitted by central and State Government ministries / departments, public sector organisations, law enforcement agencies, etc.

Scientists at Cyber Forensic Lab impart training through training workshops organised by CERT-In on computer forensics and mobile device forensics through lectures, demonstrations and hands on practical sessions, which covers seizing, preservation, processing and analysis of the raw data extracted from the digital items. CERT-In also supports other institutes in imparting trainings on various aspects of cyber forensics by delivering lectures along with demonstrations. CERT-In conducted a training on “Digital Forensics”

for APCERT operational members, which was organised by Taiwan Cert the Chair of the Training Working Group in APCERT.

National Cyber Coordination Centre (NCCC)

Continuously evolving cyber threat landscape and its impact on well being of Information Technology, national economy and cyber security necessitates the need for near-real time situational awareness and rapid response to cyber security incidents. Realizing the need, Government has taken steps to set up the National Cyber Coordination Centre (NCCC) to generate macroscopic views of the cyber security breaches and cyber security threats in the country. The centre will scan the cyberspace in the country at meta data level and will generate near real time situational awareness. NCCC is a multi-stakeholder body and is being implemented by Indian Computer Emergency Response Team (CERT-In).The centre will facilitate various organizations and entities in the country to mitigate cyber attacks and cyber incidents on a near real time basis. The phase-1 of NCCC has been operationalised in July, 2017. Implementation of NCCC phase-II has been started in March, 2019 and will be completed in various stages.



Launch of Cyber Surakshit Bharat programme by Hon'ble Minister of State (Electronics & IT) with industry leaders



Thirteenth batch of training of CISOs at IIPA Delhi

6.3.4 Cyber Surakshit Bharat

The “Cyber Surakshit Bharat” (CSB) programme was initiated in partnership with Industry consortium in Public Private Partnership (PPP) mode with the objective to educate & enable the Chief Information Security Officers (CISOs) & broader IT community of Central/State Governments, Banks and PSUs to address the challenges of cyber security. The technical content of the training was developed after intense discussion with Industry consortium. The training is being conducted in 6 cities to train and enable around 1200 officials. As on 31st Dec. 2019, fourteen batches of deep dive training have already been organised in different cities and 535 CISOs/IT officials from Government, PSUs, Banks and Government organisations have been trained. Calendar for 5 more batches up to February 2020 has already been announced.

6.3.5 Grand Challenge for Start-ups

Grand Challenge for Startup in the area of the cyber security has been conceptualized with the objective to promote innovation and entrepreneurship culture in the country to give an opportunity for entrepreneurs and researchers to work on a real big problem of cyber security and come out with a world class product. While solving the problem Government

will facilitate them with the mentorship as well as monetary support during the product development life cycle. Over all execution of Grand Challenge will be done in multiple stages which include identification of problem statements, constitution of expert committee and jury panel, launch of the event, invitation of proposals from start-ups, evaluation of proposals by Jury and identification of 12 start-ups to develop the solution. Data Security Council of India (DSCI) is acting as partner.

Jury and Expert panel have been constituted. The problem statements have been identified based on input received from various user organizations. The outreach site has been finalized. Grand Challenge will be launched very soon.

6.3.6 Notification for Preferential Market Access for Cyber Security Products

In furtherance of the Public Procurement (Preference to Make in India) Order 2017, notified by Department of Industrial Policy and Promotion (DIPP) vide notification No. P-45021/2/2017-B.E.-II dated 15.06.2017 and partially modified order no No.P-45021/2/2017-PP(BE-II) dated 28.05.2018, to encourage ‘Make in India’ and to promote manufacturing and production of goods and services in India with a view to enhancing

income and employment, Ministry of Electronics and Information Technology (MeitY) notified an order on 2nd July 2018 for promoting indigenous Cyber Security products. As per the notification cyber security being a strategic area, preference shall be provided by all procuring entities of Central Governments to domestically manufactured/produced cyber security products.

The revised notification to include (a) indicative categories of cyber security products and (b) a format for self-declaration regarding 'local supplier' was issued on 6th Dec 2019

6.3.7 Online capacity-building on Cyber Law, Crime Investigation, and Digital Forensics

Online capacity-building programme on Cyber Law, Crime Investigation, and Digital Forensics through Learning Management System (LMS) has been initiated, where "Online PG Diploma in Cyber Law, Crime Investigation & Digital Forensics" will be offered to 1000 officials of State Police working in cyber cells, Prosecutors and Judiciaries using Learning Management System (LMS) in a phased manner. Online PG Diploma is expected to be launched by Jan 2020.

6.3.8 R&D Projects under NCCC

Two R&D projects for development of indigenous tools to be used in NCCC, have been funded under NCCC as described below:

- (i) **Scalable Attack data capturing and analysis framework for Cyber Threat Intelligence**
- The objective of the project is creation of scalable framework for attack capturing and analysis. This will result in the nation-wide deployment of honey-pot sensor and creation of adaptive framework for attack modeling and generation of cyber threat intelligence. So far threat capturing honey-pot sensors have been -deployed in 60 locations. Framework for attack modeling and generation of cyber threat intelligence has been developed and it was integrated with NCCC central location.

- (ii) **Development of Big Data based indigenous Security Information and Event Management (SIEM) and integrated Security Analytics for detection of Security Attacks** - The objective of the project is to create an indigenous Security Information and Event Management (SIEM) system with integrated big data analytics to derive Situational Awareness in Indian cyber space. The system will also integrate with indigenously developed Traffic Flow Analytics, DNS Analysis and BGP attack detection systems. The system (SIEM) is already installed at central location of NCCC and at other locations/organizations identified by CERT-In.

6.3.9 National Critical Information Infrastructure Protection Centre (NCIIPC)

National Critical Information Infrastructure Protection Centre (NCIIPC) has been set up to serve as national agency in respect of Critical Information Infrastructure Protection as per the provisions of section 70A of the Information Technology Act. To enhance the protection and resilience of Nation's critical information infrastructure by operating 24x7 and mandating security practices related to the design, acquisition, development, use and operation of information resources.

6.3.10 North Eastern Regional Computer Security Incident Response Team (NERCSIRT)

A vision document named "Digital North East Vision 2020" was released by MeitY in the year 2018 to extend reach of Digital India to North Eastern part of the country. It is envisaged in the vision document to set up a NERCSIRT with estimated investment of Rs. 100 crores in five years.

Discussion was initiated with North Eastern (NE) States to finalize the place for NERCSIRT. NE States have shown their willingness to support and setup NERCSIRT in North East. The details of setting up NERCSIRT is being worked out.

6.4. CERT-In Initiatives towards Security including Digital Payments

- The Indian Computer Emergency Response Team (CERT-In) issues alerts and advisories regarding latest cyber threats and counter measures on regular basis to ensure safe usage of digital technologies. Regarding securing digital payments, 28 advisories have been issued for users and institutions.
- All authorised entities/ banks issuing PPIs in the country have been advised by CERT-In through Reserve bank of India to carry out special audit by empanelled auditors of CERT-In on a priority basis and to take immediate steps thereafter to comply with the finding of the audit report and ensure implementation of security best practices.
- Government has issued guidelines for Chief Information Security Officers (CISOs) regarding their key roles and responsibilities for securing applications / infrastructure and compliance.
- Government has empanelled 76 security auditing organisations to support and audit implementation of Information Security Best Practices.
- All organizations providing digital services have been mandated to report cyber security incidents to CERT-In expeditiously.
- Government has formulated Crisis Management Plan for countering cyber attacks and cyber terrorism for implementation by All Ministries/Departments of Central Government, State Governments and their organizations and critical sectors.
- Cyber security mock drills and exercises are being conducted regularly to enable assessment of cyber security posture and preparedness of organizations in Government and critical sectors. 38 such exercise have so far been conducted by CERT-In where organisations from different sectors such as Finance, Defence, Power, Telecom, Transport, Energy, Space, IT/ITeS etc participated. 3 exercises were Information Security Officers (CISOs) of banks.
- CERT-In conducts regular training programmes for network/system administrators and Chief Information Security Officers (CISOs) of Government and critical sector organizations regarding securing the IT infrastructure and mitigating cyber attacks. 22 trainings covering 746 participants conducted in the year 2018 (till November).
- Government has launched the Cyber Swachhta Kendra (Botnet Clearing and Malware Analysis Centre). The centre is providing detection of malicious programmes and free tools to remove the same.



Chapter – 7

Skill India: Capacity Building



7.1 Skill India

Activities of MeitY are targeted to support availability of trained human resources for the manufacturing and service sectors of electronics and IT industry. Initiatives include identifying gaps emerging from the formal sector and planning programmes in non-formal and formal sectors for meeting these gaps. This includes skill development in the domain of electronics and IT and related areas. In the succeeding sections, various ongoing initiatives, including skill development and an indicative list of major schemes/projects are presented.

The skill development activities of the Ministry are primarily being taken up by its two autonomous societies viz. National Institute of Electronics and Information Technology (NIELIT), and Centre for Development of Advanced Computing (C-DAC). In addition, the various organisations/attached offices under the Department viz. ERNET India, Digital

India Corporation, CSC E-Governance Services India Limited, STQC, NIC etc. are also engaged in training of various stakeholders in small numbers. In the FY 2019-20, a total of 1,11,000 (as on Sept 2019) candidates have been trained and certified by these agencies.

7.1.1 Post Graduate and Doctorate Level

Visvesvaraya PhD Scheme for Electronic System Design and Manufacturing [ESDM] and IT/IT Enabled Services [IT/ITeS]

MeitY initiated “Visvesvaraya PhD Scheme for Electronics and IT” to (i) enhance the number of PhDs in Electronics System Design and Manufacturing (ESDM) and IT/IT Enabled Services (IT/ITeS) sectors in the country (ii) give thrust to Research and Development (iii) create an innovative ecosystem and enhance India’s competitiveness in these knowledge intensive sectors.

The scheme supports full-time and part-time candidates in ESDM and IT/ITeS sectors. The scheme also targets to support 200 Young Faculty Research Fellowships (YFRF) in the areas of ESDM and IT/ITeS with the objective, to retain and attract bright young faculty members in these sectors. It also provides for infrastructural grant of Rs.5 lakh per full-time candidate to the academic institutions for creation/up-gradation of laboratories. Part-time PhD candidates also get one time incentive on completion of the PhD. The scheme was initiated in 2014 for a period of nine years with a total estimated cost of Rs.466 crore.

Under the scheme (as on 9th December, 2019) 932 full-time and 292 part-time PhD scholars are pursuing PhD at 96 academic institutions (Central Universities/Institutions and Colleges/Institutions of National importance/State Universities/Deemed Universities/ Institutions) across the country. The scheme is also supporting 154 “Young Faculty Research Fellows” to encourage and recognize young faculties involved in research and technology development.

Periodical research workshops are organised to improve the quality of research being pursued by the PhD scholars and young faculty research fellowship (YFRFs) and to assess their research work. In these workshops, selected scholars and YFRFs present their research work to the Academic Committee and other research experts. Experts review and evaluate research work of PhD Scholars/YFRFs and also provide critical comments and suggestions to improve their research work.

A total of 5 Workshops for Research Fellows (in Mumbai, Bengaluru, Visakhapatnam, Jaipur and Chandigarh covering around 950 Research Scholars) and 3 workshops for YFRF awardees (at IISc Bengaluru) were held during FY 2019-20.

The PhD Scheme was also evaluated by Mid-Term Evaluation committee consisting domain

experts. The Committee appreciated the Scheme and observed that it has helped to develop capacity building in niche areas of electronics, IT and computer sciences coupled with infrastructure development. It further recommended the continuation of the scheme with more full time PhD seats and introduction of “Post-Doctoral Fellowship”.

7.1.2 Graduate level

Scheme of Financial Assistance for setting up of Electronics and ICT Academies

The objective of the scheme is to set up seven Electronics and ICT Academies, as a unit in IITs, IIITs, NITs, etc., for faculty/mentor development/up gradation to improve the employability of the graduates/diploma holders in various streams, through active collaboration of States/UTs, with financial assistance from the Central Government. Electronics and ICT Academies are aimed at providing specialised training to the faculties of the engineering, arts, commerce and science colleges, polytechnics etc, by developing state-of-art set up facilities. The seven academies have been set up and are operational at IIT Kanpur (Uttar Pradesh), IIT Guwahati (Assam), NIT Patna (Bihar), NIT Warangal (Telangana), IIITD&M Jabalpur (Madhya Pradesh), IIT Roorkee (Uttarakhand) and MNIT Jaipur (Rajasthan). These academies are conducting various faculty development programmes in Electronics and ICT.

The Academies have been conducting Faculty Development Programmes (FDPs) in the conventional classroom mode, NKN mode and through online mode. FDPs (8) in core areas of Electronics and Information & Communication Technology (ICT) streams, have already been delivered by Academies during summer vacations 2019. All these 8 courses were delivered through NKN based Video Conferencing, with lectures delivered by invited experts from IITs, NITs, IIITs

and other premier institutes/ industries. In addition, sessions on design orientation/ activity linked problems/ assignments/ case studies and quiz test(s) etc are addressed locally. Academies are also now going to conduct further 6 courses through NKN mode, during winter vacations (i.e. December, 2019 – January, 2020). Various publicity measures have already been taken up through this Ministry and at the Academy level to attract wider spectrum of participants under these courses.

The Academy at IIT Kanpur is delivering training to the faculty through an Online Platform set up for the purpose. About 109 courses are already live on the platform. The Academy is also imparting training to faculty of Abdul Kalam Technical University (AKTU) under a joint programme between the Academy and AKTU in all basic and advanced level subjects, as relevant to the undergraduate level streams of Electronics and Communication Engineering, IT and Computer Science. This initiative would certainly be able to nurture students who would be industry ready in globally emerging areas in Electronics and ICT domains, and would be readily employable.

As on 31st December 2019, 1,024 Faculty Development Programmes (FDPs) have been conducted benefitting 59,918 participants (Faculty: 49,789; Students/others 10,129).

7.1.3 Vocational Skill Development Level

(i) Two Schemes on Skill Development in ESDM sector are under implementation:

(a) Scheme for financial assistance to select States/UTs for Skill Development in ESDM sector

The scheme has been approved with a target of skilling 90,000 candidates (at 5 levels). The scheme is under implementation in following States viz. Andhra Pradesh (50% target)

Telangana (50% target), Jammu & Kashmir, Karnataka, Punjab, Uttarakhand (for two levels only) and Uttar Pradesh.

(b) Scheme for ‘Skill Development in ESDM for Digital India’

This expanded scheme has been approved with a target of skilling 3.28 lakh candidates for implementation in 32 States/UTs.

Under the above two schemes, training is imparted in 63 NSQF aligned courses and 1 NOS based course, through 2,687 training partners duly registered with NIELIT/ Electronics Sector Skill Council of India (ESSC)/ Telecom Sector Skill Council (TSSC). As on 31st December, 2019, under both the above schemes, a total of 3.56 lakh candidates have been enrolled for training in various States/UTs, out of which 3.20 lakh candidates have been trained and 2.07 lakh candidates have been certified.

(ii) Efforts to generate greater participation of Industry through Sector Skill Councils - Electronics, Telecom, IT/ITeS

MeitY is actively associating and supporting the various skill development activities of the following Sector Skill Councils (SSCs) concerning the domains addressed by this Ministry:

- Electronics Sector Skill Council of India (ESSCI)
- iTelecom Sector Skill Council (TSSC)
- NASSCOM IT- ITeS Sector Skill Council

The above Sector Skill Councils have taken up various courses for skilling of candidates in their respective domains. Ministry has also supported development of new job roles/NOSs with ESSCI & NASSCOM IT/ITeS Sector Skill Council.

7.1.4 Capacity Building in Niche Areas

Special Manpower Development Programme in Chips to System Design (SMDP-C2SD)

An umbrella Programme under 'Digital India Programme' has been initiated in December 2014 at 60 Academic/Research & Development institutions, spread across the country including all IITs, NITs, IISc, IIITs & other Engineering Colleges. The aim is to train 50,000 number of specialized manpower over a period of 5 years in the area of VLSI design and inculcate the culture of System-on-Chip/ System Level Design at Bachelors, Masters and Research level. The programme has an outlay of Rs.99.72 crore for duration of 5 years. Major achievements under the program so far are:

- About 44,000 number of manpower at B.Tech, M.Tech & PhD level trained in VLSI/ System design area.
- 15 projects are in progress for development of working prototype of Systems/ Sub-systems/ SoCs along with the development of about 125 Application Specific Integrated Circuits (ASICs) and 30 Field Programmable Gate Array (FPGA) based board level designs.
- VLSI design labs, equipped with State-of-the-art EDA Tools & Hardware Equipment, setup at 60 participating institutes, for implementing VLSI/ System design projects.
- About 70 Chips fabricated till date at SCL Mohali & other foundries and 55 designs are ready to be sent for fabrication.
- 13 Instruction Enhancement Programmes (IEP) organized to train the faculty members of institutes participating under SMDP-C2SD in the area of VLSI/ System design.

- M.Tech programme in VLSI/ embedded system design initiated at 17 SMDP-C2SD institutions that did not have these courses earlier.
- Website for SMDP-C2SD developed (www.smdpc2sd.gov.in) for dissemination of educational material, web based project administration for all the institutions participating in the program and maintaining repository of reusable IPs/ IEPs/ Video Lectures etc.
- About 17 Patent (National/International) filed and ~15,00 research papers published in Conference proceedings / Journal publications.
- To make available industry-ready specialized manpower in VLSI/ System design area, about 175 students from SMDP-C2SD institutions sent to Intel for internship of 6m-1year. Out of these, 30 students provided job offer by Intel.

Indian Nanoelectronics Users Program (INUP)

Based on the great success of project "Indian Nanoelectronics Users Programme (INUP)-Phase I"- a joint project between IISc, Bengaluru and IIT Bombay, a major project "Indian Nanoelectronics Users Programme (INUP)-Phase II"- a joint project at IISc, Bengaluru and IIT Bombay had been implemented in the area of nanoelectronics across the country by organising the hands on workshops as well as to train them by undertaking the R&D projects on different aspects of nanoelectronics. The approach adopted under this project has been to make available large research facilities created at nanoelectronics centres at IISc and IIT Bombay to the researchers across the country.

INUP Phase II program completed in August 2019, continues to facilitate and support the generation of expertise and knowledge in Nanoelectronics through participation by external users in INUP and

their utilization of the facilities established at the Centres of Excellence in Nanoelectronics (CEN) at IISc, Bengaluru and IITB.

Following are the achievements of program so far:

- 7,500 skilled manpower has been trained across the country in the area of Nanoelectronics so far under the INUP project.
- 717 journal/conference publications and 41 patents have been filed. And 584 of these have been supported under the program.
- 1,107 R&D projects have been supported so far.
- 53 familiarization workshops and 103 hands on training have been conducted by IISc Bengaluru and IIT Bombay.

Skill Development School for Paramedical Training by JSV Innovations Private Limited has been established of at Centre for Nanoelectronics, IIT Guwahati.

Information Security Education and Awareness (ISEA) Project Phase-II

Under the ISEA Project Phase-II, 1.14 lakh persons are proposed to be trained under formal and non-formal courses, faculty training etc. In addition, about 400 Paper publications are expected. The project also aims to provide training to more than 13,000 Government officials and creating mass information security awareness targeted towards academic users, Government users and general users (approximately 3 crore Internet users in five years through direct and indirect mode). 52 institutions have been identified for the implementation of academic activities under the project.

As on 31st Dec, 2019, 51,164 candidates are undergoing training/trained in various formal/non-formal program. Further, 8,788 Government officials have

been trained beside this 1041 awareness workshops have been conducted across the country covering 1,35,684 participants.

7.1.5 Grass Root Level

“Pradhan Mantri Gramin Digital Saksharta Abhiyan” (PMGDISHA)

The Government of India has approved a scheme titled “Pradhan Mantri Gramin Digital Saksharta Abhiyan (PMGDISHA)” to usher in digital literacy in rural India by covering 6 crore rural households (one person per household). To ensure equitable geographical reach, each of the 2,50,000 Gram Panchayats across the country are registering an average of 200-300 candidates.

Special focus of the said Scheme is on training the beneficiaries on use of Electronic Payment System. The outcome measurement criteria include undertaking at least 5 electronic payments transactions by each beneficiary using UPI (including BHIM app), USSD, PoS, AEPS, Cards & Internet Banking.

The total outlay of the above Scheme is Rs. 2,351.38 crore (approx.). It is being implemented as a Central Sector Scheme by the Ministry of Electronics & Information Technology through an implementing agency namely CSC e-Governance Services India Limited, with active collaboration of all the State Governments and UT Administrations.

The Implementing Agency of the Scheme has conducted 128 State level workshops and 1082 District level awareness workshops for the training centres till October 2019. As on 31st December, 2019, a total of 3.19 crore beneficiaries have been enrolled, out of which training has been imparted to 2.56 crore beneficiaries, out of this more than 1.88 crore beneficiaries have been certified under the PMGDISHA Scheme.

7.1.6 Create skill development facilities in deprived areas through strengthening of National Institute of Electronics and Information Technology (NIELIT)

Ministry of Electronics and Information Technology (MeitY) is implementing a Project approved by the Cabinet with budget outlay of Rs. 287.00 crore (GIA of Rs. 259.67 crore). The project objective includes up-gradation of the three existing NIELIT centers located at Imphal, Aizawl, Gangtok; Setting up of seven new Extension centers at Senapati and Churachandpur in Manipur; Dibrugarh, Jorhat and Kokrajhar in Assam; Lunglei in Mizoram; Pasighat in Arunachal Pradesh; and upgradation of two existing extension centers located at Chuchuyimlang in Nagaland and Tezpur in Assam, to increase the training capacity from 3,080 per year to 14,400 per year from the 5th year onward. As of now the annual training capacity of these centers (including six centers operational from temporary locations at Guwahati and Silchar in Assam; Itanagar and Tezu in Arunachal Pradesh; Shillong and Tura in Meghalaya) is around 20,000 candidates. Presently all the NIELIT Centres/extension centers are operational from permanent/ temporary premises. The above 12 NIELIT Centres/Extension Centres are at different stages of construction under the project and so far more than 1,50,000 candidates have been trained in various Electronics & ICT courses.

7.1.7 IT for Masses Programme

The objectives of IT for Masses Programme under Manpower Development scheme is to initiate/promote activities in ICT for focus groups (Women, Scheduled Caste, Scheduled Tribe, Senior Citizen, Differently Abled, Economic Weaker Section (EWS) and Minorities) and areas (North Eastern Region, Backward Districts and Blocks & Districts having more than 40% SC/ST population) for inclusive growth of IT Sectors through Infrastructure Creation,

Training, Capacity Building & Entrepreneurship Creation activities in IT domain.

Ministry is earmarking funds for SCSP, TSP and General components. The programme caters exclusively for the benefit/development of focus group i.e. Women, Scheduled Caste, Scheduled Tribe, Senior Citizen, Differently Abled, Economic Weaker Section (EWS) and Minorities.

During the F.Y. 2019-20, the projects implemented in 6 states and a UT which have directly benefitted about 1095 (SC:152, ST:861 & Women:82) number of candidates. The following projects initiated/on-going:

Development of Weaker Sections

Projects covering Scheduled Caste (SC)/Scheduled Tribe (ST), Differently Abled and Economic Weaker Section (EWS) beneficiaries

- Empowering underprivileged ST of four backward districts of Nagaland through ICT skills training – Nagaland
- Empowerment of SC/ST Youth & Women on Enhancement of Livelihood activities using IT & Tool and PMU for IT for Masses- West Bengal
- Development of IT solution (Mobile/web App) in Hindi Language on self-employment schemes for empowerment of SCs, STs and women in Himachal Pradesh – Himachal Pradesh
- Skill Development Training of Unemployed SC & ST youths of Tripura towards enabling entrepreneurship & sustainable development – Tripura
- Training of Visually Impaired Persons in Manipur on “Course on Computer Concepts (CCC) of NIELIT – Manipur
- Skill Development Training for the Masses under ICT – Maharashtra

Development of Women/Girls using ICT

Gender Empowerment through ICT has been one of the major initiatives of the Government. MeitY has also been implementing various ICT training/capacity building projects for the empowerment of women in different States/UTs.

The following projects initiated/on-going:

Projects covering Gender (Women) beneficiaries

- Development of IT solution (Mobile/web App) in Hindi Language on self-employment schemes for empowerment of SCs, STs and women in Himachal Pradesh – Himachal Pradesh
- ICT Intervention for Development & Livelihood Enhancement through Self Help Groups (SHGs) in Majhwa block of Mirzapur (a backward district) – Uttar Pradesh.
- Skill Development Training for the Masses under ICT – Maharashtra
- ICT based capacity building for empowerment in the area of health and livelihood for the women belonging to SC/ST community in Latur district of Maharashtra – Maharashtra

Fee-reimbursement Programme

As per the directions received from NITI Aayog (the then Planning Commission) through MeitY (then DeitY) Vide their communication No.D.O.No.M-13054/2/2005-BC dated 05.09.07, NIELIT is implementing the Scheduled Caste Sub Plan (SCSP) for Scheduled Castes and Tribal Sub-Plan (TSP) for Scheduled Tribes since 2007-08. According to the directions and guidelines for implementing the scheme, no fee should be charged from the SC and ST candidates for educational and skill development programmes by the Government and autonomous institutions and the expenditure for the Scheme should be accounted for from the SCSP and TSP fund of the respective Ministries / Departments.

Since then, NIELIT Centres are implementing the scheme with the financial support of MeitY. Under this scheme, no fees are being charged from the SC or ST candidates for undergoing courses offered by NIELIT. Further, NIELIT providing undertaking that the beneficiaries are not included under projects already funded/being funded by MeitY (either from core grant or from IT for Masses or Other Schemes/ Programmes) or by other Ministries/Departments of the Central / State Government.

7.1.8 Re-skilling/up-skilling of IT professionals

The job scenario in IT-BPM Industry is undergoing a transformation due to adoption of automation and emergence of newer technologies (including disruptive technologies). New job roles requiring different skill-sets are appearing and earlier jobs based on older skill-sets are losing their relevance. Hence, the Government, IT Industry and the academia, need to join together to create an ecosystem for re-skilling/up-skilling of the employees of IT Industry, so as to retain the edge that India has in the IT sector through its young and dynamic workforce. To cater to all these requirements, MeitY and NASSCOM have jointly conceived a new initiative titled “FutureSkill PRIME (Programme for Re-skilling/Up-skilling of IT Manpower for Employability)”, with an aim to create a re-skilling/up-skilling ecosystem for B2C in emerging and futuristic technologies (i.e. Artificial Intelligence, Internet of things, Big Data Analytics, Robotic Process Automation, Additive Manufacturing/3D Printing, Cloud Computing, Social & Mobile, Cyber Security, Virtual reality and Blockchain etc) to facilitate continuous skill as well as knowledge enhancement of the professionals in line with their aspirations and aptitude in a self-paced digital skill environment. The total outlay of the programme is as Rs. 436.87 crore over a period of three years with a target to cover 4.12 Lakh beneficiaries (4 lakh Professionals, 10,000 Government Officials and 2,000 Trainers).

Chapter – 8

Statutory Organisations



8.1 Authentication framework under the IT Act, 2000 - CCA

The Information Technology Act, 2000 facilitates acceptance of Electronic Records and Electronic Signatures through a legal framework for establishing trust in e-Commerce and e-Governance. For authentication of electronic transactions using electronic signatures, the Controller of Certifying Authorities (CCA) licenses Certifying Authorities to issue Electronic Signature Certificates under the IT Act 2000. Currently, Twelve Certifying Authorities (CAs) are operational. The total number of Electronic Signature Certificates (ESC) issued in the country grew to more than 2.55 crore (out of which 9.67 crore ESCs are for eSign) by 31st December, 2019 and continues to grow rapidly and is expected to increase significantly with the launch of various e-Governance/e-Commerce programmes.

For ensuring continued trust in this authentication framework, Annual Compliance Audits of Certifying Authorities were conducted as per the requirements of the Information Technology Act, 2000. In addition to the regular Annual Compliance Audits, Special Audits were also carried out for ensuring compliance to the Identity Verification Guidelines (IVG) to be followed in the Digital Signature Certificate (DSC) issuance process.

One (n)Code CA licence was renewed this year & eight applications from prospective organizations (Army, CSC, RISL, Pentagon, QCID, Airtel, CDSL, Reliance) have been processed to become licensed CA. Out of eight applications, three applications (Army, CSC, RISL) have been granted CAs' licence and remaining five applications (Pentagon, QCID, Airtel, CDSL, Reliance) are under examination for processing of licence.

8.1.1 eSign online electronic signature Service for Aadhaar Holders

Seven licensed CAs which are empanelled ESPs (viz. eMudhra, (n)Code, RISL, Verasys, CDAC, NSDL & Capricorn) are providing eSign service in the country. Total number of eSign Electronic Signatures reached 9.67 crore by 31st December, 2019. Initiatives are being taken in this respect through coordinated interactions between the e-Governance/e-Commerce application service providers and these ESP/CAs to facilitate the maximum use of eSign.

Technical Infrastructure

The Root Certifying Authority of India (RCAI) set up by the CCA is at the root of trust for authentication through Digital Signatures. Repository containing certificates issued by CCA to the licensed CAs and the Certificates issued by the licensed CAs to subscribers has been established and is being operated by the Office of CCA for checking compliance with the Interoperability Guidelines and for Statistical Purposes. The Disaster Recovery Site for the RCAI continues to be operational.

- **Enabling paperless mode of DSC issuance:** Enabled options for migrating Digital Signature Certificates (DSC) issuance to paperless mode by verification based on offline KYC, banking, organizational KYC, PAN eKYC and eSign service.

In the traditional mode, the Digital Signature Certificates (DSC) to the subscriber are issued based on the paper based application form & duly attested supporting documents including address and identity proof of the applicant. This whole process has been dispensed with after the issuance of guidelines along with KYC to be provided through alternate mode like offline Aadhaar, banking KYC, organizational KYC and PAN based eKYC.

Existing Certifying Authorities namely eMudra, Verasys & Capricorn have started paperless mode of DSC issuance.

- **Licensed and renewed CAs:** Licensed three new Certifying Authorities namely CSC e-Governance Services India Limited, RajComp CA and Army CA) and renewed the licence of (n)Code Solutions CA during this period.
- **Processing CA Application for Licence:** New Certifying Authorities namely, CDSL, Pentagon, Reliance Jio and QCID are in the various phases of implementation of their CA development process and some of them are under audit process. These CAs will start issuance of DSCs to various subscribers.
- **Enhancing trust:** As part of its promotional role for boosting the electronic transactions for e-Commerce and e-Sign application, the Office of CCA conducts awareness programmes in the country for users who are beginners and also for application developers and relying parties. These awareness programmes are conducted across the length and breadth of the country through CDAC, Bengaluru. The proposal for funding the project has been awarded to CDAC.

Digital Locker Authority (DLA)

Under the Digital India Programme, Government of India has planned to provide shareable private space on a public cloud and to digitize all documents and records of the citizens and make them available on a real-time basis. These mechanism of 'e-Document repositories' and 'Digital Lockers' will greatly improve citizen convenience and usher in paperless transactions across the entire ecosystem of public services. The framework for the Digital Locker Ecosystem has been set up by the Controller of Certifying Authorities (CCA) who has been given additional charge to function as 'Controller of Digital Locker Authority (CDLA)'.

The office of DLA has designed, registered & launched the website (<http://dla.gov.in>). The necessary rules, regulations & guidelines along with application form, eligibility criteria, technical specifications, practice statement, undertakings & other documents related to Digital Locker Service Providers (DLSPs) and Repository Providers (RPs) are available on DLA website.

Training / Awareness Generation & Promotion of Digital Signatures

PKI Body of Knowledge: CDAC Bengaluru has been awarded project for 4 years to conduct development & dissemination programmes on Digital Signatures, Public Key Infrastructure (PKI) & online electronic/digital signature (eSign) across the length and breadth of the country by touching major sectors & societies of the states/UTs.

8.2 Unique Identification Authority of India (UIDAI)

8.2.1 Introduction

The Unique Identification Authority of India (UIDAI) is a statutory authority established under the provisions of the **Aadhaar (Targeted Delivery of Financial and Other Subsidies, Benefits and Services) Act, 2016 (referred as “Aadhaar Act 2016”)** on 12th July, 2016 by the Government of India, under the Ministry of Electronics and Information Technology (MeitY). The Aadhaar Act 2016 has since been amended by the Aadhaar and Other Laws (Amendment) Act, 2019 (14 of 2019) which was notified on 24.07.2019 and its provisions came into force on 25.07.2019.

Prior to its establishment as a statutory authority, UIDAI was functioning as an attached office of the then Planning Commission (now NITI Aayog) vide gazette notification No. A-43011/02/2009-Admn.I dated 28th January, 2009. Later, on 12th September, 2015, the Government revised the

Allocation of Business Rules to attach UIDAI to the Department of Electronics & Information Technology (DeitY) of the then Ministry of Communications and Information Technology.

The Aadhaar (Targeted Delivery of Financial and Other Subsidies, Benefits and Services) Act, 2016 (No. 18 of 2016); The Aadhaar and Other Laws (Amendment) Ordinance, 2019 (No. 9 of 2019) and the Aadhaar and Other Laws (Amendment) Act, 2019 (14 of 2019)

The Aadhaar Act, 2016 provides for good governance, efficient, transparent and targeted delivery of subsidies, benefits and services, the expenditure for which is incurred from the Consolidated Fund of India or the Consolidated fund of the State, to individuals residing in India through assigning of unique identity numbers (called Aadhaar numbers) to such individuals and for matters connected therewith or incidental thereto.

The Aadhaar (Targeted Delivery of Financial and Other Subsidies, Benefits and Services) Act, 2016 was published in the Official Gazette of India, Extraordinary, Part-II, Section 1, dated 26th March, 2016 (Act No. 18 of 2016; referred to as “Aadhaar Act, 2016”). Different provisions of the Aadhaar Act, 2016 came into force on 12.07.2016 and 12.09.2016.

A number of writ petitions were filed before various High Courts and the Supreme Court, inter-alia, challenging the validity of Aadhaar; both prior to and after the notification of Aadhaar Act, 2016. All these writ petitions were tagged by the Supreme Court with the main writ, Justice K.S. Puttaswamy and Others vs Union of India, W.P. No.(Civil) 494/2012. The final judgment in W.P. No.(Civil) No.494/2012 was pronounced on 26.09.2018 by a five Judge Constitution Bench of the Supreme Court, upholding the constitutional validity of Aadhaar with few restrictions and changes.

Following the judgement, a decision was taken to bring necessary changes in the Aadhaar Act to incorporate safeguards to ensure privacy, prevent misuse of personal information and prevent denial of services and benefits to eligible persons as per the directions of the Supreme Court and recommendations of Justice B.N. Srikrishna (Retd) Committee. Besides, changes were also required in the Indian Telegraph Act, 1885 and Prevention of Money Laundering Act, 2002 to allow voluntary uses of Aadhaar authentication for obtaining SIM cards and opening of bank accounts respectively. Accordingly, the Aadhaar and Other Laws (Amendment) Bill, 2019 was passed by the Lok Sabha on 4th January, 2019 but could not be taken up by the Rajya Sabha as it was adjourned sine die. Late on, the Aadhaar and Other Laws (Amendment) Ordinance, 2019 (No. 9 of 2019) was promulgated by the President on 02.03.2019 and came into force at once.

Subsequently, the said Ordinance was replaced by the Aadhaar and Other Laws (Amendment) Act, 2019 (14 of 2019). This amended Act inter-alia provides for use of Aadhaar authentication by the State Government, for the purpose of establishing identity of an individual as a condition for receipt of a subsidy, benefit or service for which the expenditure is incurred from, or the receipt therefrom forms part of, the Consolidated Fund of State.

8.2.2 Value Proposition of Aadhaar

8.2.2.1 Uniqueness

Any individual, irrespective of age and gender, who is a resident in India and satisfies the verification process laid down by the UIDAI, can enroll for Aadhaar. An individual is required to enroll only once; the process is free of cost. In case, the resident enrolls more than once, only one Aadhaar shall be generated, as the uniqueness is achieved through biometric de-duplication.

Authentication

One of the challenges the resident frequently faced was to establish his/her identity. Aadhaar's property of authentication enables an Aadhaar holder to authenticate with a service provider anytime, anywhere in the country to prove his/her identity. To facilitate this, UIDAI has established an ecosystem based on best global practices to ensure data privacy and reliability of authentication, with UIDAI being agnostic to the purpose of authentication.

8.2.3 Approach and Strategy: Enrolment Ecosystem

The first Aadhaar of a resident was made in September, 2010. As on 31st December 2019, **125.06** crore Aadhaar have been generated against the projected population (**2019**) of about **135.39** crore. However, the actual number of Aadhaar holders would always be lesser due to deaths. Hence, the concept of "Live Aadhaar" has been introduced to estimate the number of alive persons holding Aadhaar. As such, **121.52 crore** Live Aadhaar have been generated since inception in September, 2009. Thus, UIDAI has covered 89.76% of the projected population. The statistics as on 31st December, 2019 with information in respect of children in the age group 0 < 5 years and 5 < 18 years is provided as below:

Age Band	Population (Projected 2019)	Live-Aadhaar Generated	Aadhaar Saturation
Overall	135.39 crore	121.52 crore	89.76%
Population 5<18 years	37.17 crore	28.61 crore	77.0%
Population 0 < 5 years	12.66 crore	4.26 crore	33.7%

As majority of the adult population has already enrolled for Aadhaar, UIDAI is also focusing on Aadhaar update. UIDAI is providing assistance of Aadhaar enrolment and update through its Permanent Enrolment Centers (PECs) opened by scheduled banks, India Post and at Government office locations.

The aforementioned PECs are providing both enrolment as well as update facilities to residents. Aadhaar update has become a major activity at such PECs. While some update requests will be necessary as per Aadhaar's process, other will arise based on needs of individuals.

The following categories of residents require to update their biometrics:-

- a. Aadhaar mandated biometrics update
 - i. Children on attaining the age of 5 years
 - ii. Children on attaining the age of 15 years
 - iii. Residents with difficulties in authentication
- b. Individual need driven update requests:
 - i. Changes in life events such as marriage, migration to a new location, etc.
 - ii. Changes or addition of mobile number.
 - iii. Demographic updates due to incorrect data capture during the enrolment

Aadhaar Seva Kendra (ASK)

The Unique Identification Authority of India (UIDAI) has set up exclusive 'Aadhaar Seva Kendra' or ASK as a single stop destination for all Aadhaar services for the residents. The ASK offers dedicated Aadhaar enrolment and update services to residents in a state-of-the-art environment.

In the first phase of the Aadhaar Seva Kendra project, UIDAI plans to set up 114 ASKs across 53 cities in India. These include dedicated centres in all metro cities, all State capitals and Union Territories. The ASKs will be in addition to over 35,000 Aadhaar Kendras already being operated by banks, post offices, BSNL and State Governments. As on 31st December, 2019 a total of 29 ASKs have been made operational.

ASKs offer a comfortable air conditioned environment to residents. They are wheel-chair

friendly and have special provisions to service the elderly or specially-abled.

Residents can visit any ASK for the following services:

- Aadhaar enrolment
- Update of any demographic information in their Aadhaar - Name, Address, Gender, Date of Birth, Mobile number or Email Id
- Update of biometric data in their Aadhaar – Photo, Fingerprints and Iris Scans
- Download & Print Aadhaar

These services are available for any resident of India (including NRIs) at all ASKs across the country.

Along with the ASK project, UIDAI has launched the online appointment booking facility for residents. All UIDAI-run ASKs follow the online appointment system where any resident can book an appointment for Aadhaar enrolment or update at any convenient ASK.

Any resident can book an appointment for herself or a family member from the online appointment portal. This is a free of cost service where a resident does not require Aadhaar registered mobile number. A resident can book a maximum of 4 appointments in a month.

8.2.4 Customer Relationship Management & Logistics

I. Aadhaar Support Services

UIDAI has set up an Aadhaar Sampark Kendra (Contact Centre) which facilitates in resolving residents queries and grievances related to Aadhaar life cycle and related services. Main objectives of Aadhaar Sampark Kendra are as follows:

- a) To provide a pan India accessible toll free number and email, using which the residents can contact Aadhaar Sampark Kendra.

- b) To provide support in multiple regional languages to cater to complaints and queries from all parts of India.
- c) To provide an Interactive Voice Response (IVR) system for the residents calling the Aadhaar Sampark Kendra.
- d) To provide residents to interact with Aadhaar Sampark Kendra executive in case they wish to do the same.
- e) The residents can also log the complaints through Resident Portal of UIDAI.
- f) To create and maintain a common Customer Relationship Management (CRM) application to support residents in addressing their queries & complaints.

II. Infrastructure and Technology of Aadhaar Sampark Kendra:

Currently Aadhaar Sampark Kendra consists of:

- a) **Toll-free-number 1947:** Toll free number is accessible from anywhere in India. The short code '1947' is a Category-I toll free number allotted by DoT to UIDAI. DoT has also approved use of the short code 1947 for inbound and outbound SMS services to residents.
- b) **Contact Centre Infrastructure:** Contact centre infrastructure comprises trunk lines, PBX solution, IVR system, automatic call distributor (for call distribution across call centre facilitators), computer telephony integration unit and voice logger system. The IVRS interacts with the callers in duplex mode through synthesized recorded voice in hindi/english/ regional languages depending on state from where call is placed to service their enquiries. Hindi, English, Gujarati, Kannada, Marathi, Telugu, Bengali, Punjabi, Odia, Tamil, Assamese and Malayalam languages are currently supported in IVRS.

Following features are currently available in IVRS:

- Frequently Asked Questions.
 - Aadhaar enrollment status based on 14 digit EID search.
 - Aadhaar update status with 14 digit URN number.
 - Intelligent selection of language options on IVRS based on caller's area.
 - Status of already logged complaints.
 - Know your Aadhaar number.
 - Route calls to Aadhaar Sampark Kendra executive, if desired by the caller.
- c) **Chatbot Services–** UIDAI has implemented a chat service which is available through UIDAI official website (<https://uidai.gov.in>) under tagline "Ask Aadhaar". This Chatbot is trained to respond to the resident queries based on the predefined Standard Response Templates (SRTs) and therefore, improving the resident's experience. Chatbot also has additional features like locate PEC, Check Aadhaar enrolment/updated status, file a complaint and video frame integration.
 - d) **Aadhaar Letter Printing and Delivery**
 - Once the Aadhaar is generated, it has to be ensured that the same is printed and delivered to the resident within permissible time limits.
 - Each Aadhaar letter comprises a printed, laminated document with a photograph, date of birth, demographic information of the resident, the Aadhaar number and two secure Quick Response (QR) codes where two big QR codes digitally signed by UIDAI which contain photograph and demographic details.
 - For the printing of Aadhaar letters, UIDAI has on-boarded three printers at

various locations. Currently, the installed printing capacity is 7 lakh letters per day in 13 different regional languages.

- The Department of Post is the partner for delivery of the Aadhaar letters to the residents at the address they have provided at the time of enrolment.
- UIDAI sends Aadhaar letters for new enrolments as well as for updates. Since inception and till 31st December 2019, more than 124.25 crore Aadhaar letters have been printed and dispatched to the residents through India Post as First Class Digitally Franked articles. Similarly, 22.90 crore Aadhaar letters have been updated and dispatched to the residents through India Post as First Class Digitally Franked articles from inception till 31st December 2019.

e) e- Aadhaar:

UIDAI provides the e-Aadhaar portal for downloading the Aadhaar letter in PDF format from its website (www.uidai.gov.in).

- An Aadhaar number, in physical or electronic form subject to offline verification and other conditions, as may be specified by regulations, may be accepted as proof of identity of the Aadhaar number holder. As such the e-Aadhaar, which is digitally signed, is a valid and secure electronic document, treated at par with the printed Aadhaar letter. E-Aadhaar also prints with two secure Quick Response (QR) codes which contains photographs and demographic details. In the Aadhaar system, the resident's details can be verified through an established online authentication process. Therefore, e-Aadhaar is acceptable as a valid

proof of identity. The relevant circulars have been posted on the website of UIDAI. e-Aadhaar downloads till 31st December 2019 were 101.35 crore.

f) Order Aadhaar Reprint:

- UIDAI provides "Order Aadhaar Reprint" service on its website www.uidai.gov.in to facilitate the residents to get their Aadhaar letter reprinted and delivered through the Speed Post service of India Post by paying a nominal charge of ₹ 50.

8.2.5 Authentication Eco System

Aadhaar Authentication

Aadhaar authentication means the process by which the Aadhaar number, along with demographic information or biometric information of an individual, is submitted to the Central Identities Data Repository (CIDR) for its verification and such Repository verifies the correctness, or otherwise, on the basis of information available with it.

Authentication implementation Model

UIDAI provides authentication and e-KYC services through agencies called as Authentication User Agency (AUA), e-KYC User Agency (KUA) and Authentication Service Agency (ASA), which are appointed as per Regulation 12 of Aadhaar (Authentication) Regulations, 2016.

Authentication Service Agency (ASA)

ASA is the agency that has secured leased line connectivity with CIDR. ASAs transmit authentication requests of AUAs to the CIDR. They play the role of enabling intermediaries through secure connection established with the CIDR. ASAs receive CIDR's response and transmit back the same to the AUAs. As on 31st December 2019, 23 ASAs were active in UIDAI Ecosystem.

Authentication User Agency (AUA)

AUA is any government/public/ private legal agency registered in India that uses Aadhaar authentication for providing its services to the residents/customers. An AUA is connected to the UIDAI data centre/ Central Identity Data Repository (CIDR) through an ASA (either by becoming ASA on its own or taking services of an existing ASA) using a secured protocol. As on 31st December 2019, 183 such entities are live in UIDAI ecosystem as AUAs and 3,709.41 crore authentication transactions have been performed since inception.

KYC User Agency (KUA)

KUAs are extension of AUAs that use e-KYC Services of UIDAI. As on 31st December 2019,

167 KUA entities are active on Aadhaar platform and 773.27 crore e-KYC transactions have been performed.

8.2.6 Training, Testing and Certification ecosystem

For success of any program, especially on scale such as that of UIDAI, it is imperative that there is emphasis on quality of data collected during enrolment. Additionally, it is equally important that the people who are responsible for capturing and using the Aadhaar data are adequately trained. To ensure this, UIDAI has worked diligently to create a Training, Testing and Certification ecosystem. This ecosystem consists of (1) Content Development Agency and (2) Testing and Certification Agency.

Details of Training Imparted (01.04.2019-31.12.2019)

S. No.	Type of Training	Participants	No. of Sessions	Number of Participants Trained
1	Orientation program–Enrollment Staff	New/ Fresh Enrolment Staff	224	8111
2	Mega Training–Enrollment Staff	Government Officials nominated to become Enrolment Staff	147	6768
3	Refresher Training–Enrollment Staff	Existing Enrolment Staff	400	17463
4	Master Training–Authentication and Seeding	Government Officials and Authentication User Agency Staff	14	872
	Total		785	33214

Certified candidates details (01.04.2019-31.12.2019)

RO	Banks	Postal Department	Education Department	Health Department	Others	Total
Chandigarh	909	482	208	420	2,515	4534
Guwahati	0	49	107	0	101	257
Lucknow	198	509	775	0	175	1657
Ranchi	647	571	0	0	816	2034
Bengaluru	76	194	0	0	1,1760	2030
Delhi	951	465	188	0	598	2202
Hyderabad	388	936	3052	147	930	5453
Mumbai	4597	669	26	0	1655	6947
Total Summary	7766	3875	4356	567	8550	25114

8.2.7 Intranet & Knowledge Management Portal

'Intranet & Knowledge Management Portal' (KM Portal) is an online community based platform established by UIDAI to promote internal communications, better information exchange and teamwork amongst UIDAI staff. KM Portal has KM Dashboard where latest office orders, circulars, tenders, other UIDAI related documents etc. are uploaded by various divisions, Regional Offices and Managed Service Provider. In addition, it hosts various portals/modules developed for use by different divisions such as:

- Human Resource Management System Application
- Asset Management System
- Office Management (e-office)
- VIP File Sharing System
- Travel Management System

Development and Integration of QR Code reader with Asset Management System:

Currently, the work of integration and implementation of QR Code reader with Asset Management System is going on. This will assist in extracting details of the assets of UIDAI issued to the employees as well as lying in store and include particulars like asset ID, serial number, date of procurement, unit price etc.

8.2.8 UIDAI Website

The UIDAI website (<https://www.uidai.gov.in>) is the single click Aadhaar online service window for residents of India, as well as the primary web information centre for various ecosystem partners and the public at large. Bulk of residents in India seek Aadhaar services and related information via mobile. In order to reach out to those mobile users and to ensure the accessibility of the Aadhaar services is improved, the UIDAI website and Aadhaar service portals have recently been revamped and made multi device friendly. In addition the information is

available in English, Hindi and 11 Indian regional languages for diverse demographics of the country. The home page of the website and other service portals are shown below:-



UIDAI Website as Common Repository

The UIDAI website functions as a common repository of the following:

- Policies, guidelines, checklists and other on-boarding documents which are critical for ecosystem partners. The same is available in the resources section.
- The Aadhaar (Targeted Delivery of Financial and Other Subsidies, Benefits and Services) Act, 2016, and associated Rules, Regulations, Notifications and Circulars are prominently placed under legal section.
- MoUs with State and non-State Registrars, tenders and related documents for business users are available under enrolment documents and UIDAI documents in the resources section.
- News, press releases, Aadhaar related campaigns, videos and FAQs, in downloadable format, are available under media section.

Single-point access to Online Aadhaar Services and other Portals

The UIDAI website also provides a direct link to the following services, analytics and business specific portals:

- Locate an Enrolment Centres

- Book an appointment
- Check Aadhaar Status
- Download Aadhaar
- Retrieve Lost or forgotten UID/EID
- Update Aadhaar at Enrolment/update Centre
- Check Aadhaar update Status
- Address Update Request (Online)
- Request for Address Validation Letter
- Check online address update status
- Aadhaar Update History
- Verify an Aadhaar Number
- Verify Email/Mobile Number
- Lock/Unlock Biometrics
- Aadhaar Lock and Unlock service
- Check Aadhaar / Bank Account Linking Status
- Aadhaar Authentication History
- Aadhaar Paperless offline e-KYC
- Virtual ID (VID) Generator
- Order Aadhaar Reprint
- Check status of Aadhaar Reprint

Aadhaar Dashboard: The analytic dashboard displays the big data for Aadhaar enrolment, update, authentication and e-KYC services.

8.2.9 Unified Mobile App

UIDAI has recently released an upgraded version of mAadhaar App that unifies the previously developed mobile application (mAadhaar, Resident App and QR Code scanner) into one single app. The app is available in both Android and IOS version and features an array of Aadhaar services that can be accessed both in online and offline mode. The App provides a personalized section for the Aadhaar holder, who can carry her Aadhaar information in the form of a softcopy instead of carrying a physical copy all the time. Residents with or without Aadhaar

can install this App in their smart phones. However, to avail of personalized Aadhaar services the resident will have to register her Aadhaar profile in the App. To reach out to residents in different parts of the country, the App has been made available in English, Hindi and 11 Indian languages.

8.2.10 Security and privacy of Aadhaar

Privacy and Security of Aadhaar data is of utmost importance to Government:

UIDAI has a well-designed, multi-layer robust security system in place and the same is being constantly upgraded to maintain highest level of data security and integrity. The architecture of Aadhaar ecosystem has been designed to ensure data security and privacy, which is an integral part of the system from the initial design to the final stage. For further strengthening of security and privacy of data, security audits are conducted on regular basis and all possible steps are taken to make the data safer and protected.

The Government accords utmost priority to privacy of Aadhaar data which is evident from the following fundamental binding principles on which Aadhaar has been designed and which have been further reinforced through the various provisions of the Aadhaar Act and the Regulations framed thereunder. Section 29 of the Aadhaar Act prohibits sharing or disclosure of core biometric for any purpose, violation of which is punishable under Section 37 of the Act with imprisonment upto three years. Unauthorized access to Central Identities Data Repository (CIDR) is punishable with imprisonment upto 10 years (Section 38). Tampering of data in CIDR is also punishable with imprisonment upto 10 years (Section 39).

Regulations under the Aadhaar Act have been promulgated to ensure that enrolment, authentication and other associated activities are carried out strictly in accordance with law. Aadhaar

(Enrolment and Update) Regulations, 2016 ensure that enrolment are done under a secure and legal process wherein responsibility and accountability of all the agencies involved in the process are clearly defined. Further, the Aadhaar (Authentication) Regulations 2016 have been framed to ensure that authentications are done in secure conditions.

Privacy and Security by Design

Security and privacy of personal data have been fundamental in design of Aadhaar system without sacrificing utility of the identity system. Aadhaar system is focused on identity. It only collects minimal data necessary to provide unique identity, issue the Aadhaar number after biometric de-duplication, manage lifecycle changes of that identity record and provide an Application Programming Interface (API) for verifying the identity (online authentication) for various applications requiring identity verification. Designing the Aadhaar system as an identity platform allowed clear separation of duties and leaves usage of identity to other partners and their various applications which may be built on top of the Aadhaar platform. Aadhaar number is a random number with no built-in intelligence or profiling information. A 12-digit number was chosen based on the identification needs of the population in the next couple of centuries.

Aadhaar enrolment through a secure process

UIDAI has set up a nationwide infrastructure for Aadhaar enrolment of residents of India through a network of registrars and accredited enrolment agencies. The registrars are largely the Government departments, agencies and public sector banks. Enrolment agencies are selected through rigorous selection criteria. A resident is enrolled by a UIDAI certified operator through UIDAI software under a highly robust, controlled, non-repudiable and secure process. Residents are enrolled for Aadhaar across the entire country through more than 30,000 certified operators, who are selected on the basis

of a rigorous examination and test process. The operator also has to obtain his own Aadhaar number first and then sign each and every enrolment through his own finger-prints and Aadhaar number. In this manner, a complete account is maintained as to which operator enrolled whom, where and when so that in case of any default accountability of the enrolment operator and agency can be immediately fixed. Then, the biometric data of people, who are enrolled, are matched against the entire data base of the existing Aadhaar holders, which are presently more than 125 crore and only when no match is found, Aadhaar numbers are generated. Biometric matching of this scale is done in a time span of 24 hours. All enrolment data including biometrics are encrypted by 2048 bit encryption key at the time of enrolment and is not accessible to any agency, except UIDAI, which can access these data only through a secure decryption key available to UIDAI only. It is worth mentioning that it may take the fastest computer on the earth billions of years to break this encryption key. So far, not a single incident has come to the notice wherein core biometrics of a resident enrolled for Aadhaar has been leaked.

Minimal Data with No Linkage

Since Aadhaar system has data of all Aadhaar holders of the country in a central repository, it was designed to capture minimum data so as to provide identity related functions (issuance and authentication). This design philosophy is derived directly from the fact that UIDAI respects privacy of the residents and does not hold non-essential data within its systems. In addition to having minimal data (4 attributes – name, address, gender and date of birth - plus 2 optional data – mobile, email), this central database does not have any linkage to existing systems/applications that use Aadhaar. This essentially creates a set of data islands containing resident data across various applications/systems (a federated model for resident data) rather than a

centralized model, eliminating the risk of a single system having complete knowledge of resident and her transaction history.

No Pooling of Data

Aadhaar system is not designed to collate and pool various data and hence does not become a single central data repository having all knowledge about residents. It has no linkage information (such as PAN, Driver's License Number, PDS card number, EPIC number, etc.) to any other system. This design allowed transaction data to reside in specific systems in a federated model. This approach allowed resident information to stay in distributed fashion across many systems owned by different agencies.

Authentication

Aadhaar authentication responds only with yes/no answer. Aadhaar authentication allows applications to verify the identity claim by the resident while servicing them and still protecting their data privacy. A balance between 'privacy and purpose' is critical to ensure convenience as well as protection of resident's identity data. External user agencies do not have access to the Aadhaar database. Aadhaar e-KYC service allows resident to authorize UIDAI to share electronic version of their Aadhaar letter. For every Aadhaar e-KYC request, only after successful resident authentication, demographic and photo data is shared in electronic format.

Optimal Ignorance

Authentication is designed in such a way that neither the "purpose" of authentication nor any other transaction context is known to Aadhaar system. This design was precisely to create a "zero-knowledge" system to protect privacy. Authentication of an Aadhaar number holder by an agency does not entitle Aadhaar system to know the objective for which authentication is carried out.

No Location Awareness

UIDAI authentication system does not have location awareness i.e. Aadhaar authentication is oblivious to the location from where the authentication request is sent thereby eliminating the risk of a resident being tracked.

Federated Data Model & One Way Linkage

By its very design, Aadhaar database does not have all domain specific transaction data and hence the resident's specific transactional data remains federated across many user agencies' databases rather than centralized into a common database. It is also important to note that the various systems may have made references to the UIDAI (through the use of the Aadhaar number), but the UIDAI does not maintain reverse links to any of these systems. Aadhaar seeding is, therefore, strictly a one-way linkage wherein the Aadhaar number is incorporated into the beneficiary database without pooling any data from the said database into the UID database.

Security of Aadhaar Data

UIDAI uses one of world's most advanced encryption technologies in transmission and storage of data. Aadhaar based authentication is robust and secure as compared to any other contemporary systems. Aadhaar system has the capability to inquire into any instance of misuse of Aadhaar biometrics and initiate action.

UIDAI certified as ISO 27001

UIDAI has established the Information Security Management System and obtained the ISO 27001:2013 certification from STQC.

Declaration of CIDR Infrastructure as "Protected System"

Security of UIDAI-CIDR information is of paramount importance for safeguarding resident

data. Confidentiality, integrity and availability of the information is maintained at all times through controls that are commensurate to the criticality of the information assets, so as to protect the information systems from all types of threats. UIDAI-CIDR has also been declared as “**Protected System**” by National Critical Information Infrastructure Protection Centre (NCIIPC) adding another layer of IT security assurance.

Governance Risk Compliance and Performance Service Provider (GRCP-SP)

The vision of GRCP framework is to facilitate creation of a robust, comprehensive and secure environment for UIDAI to operate. To achieve the goals, the GRCP-SP provides UIDAI management with oversight of UIDAI and partner ecosystem in terms of visibility, effectiveness and control.

Information Security Assessment of External ecosystem partners

UIDAI security has been enhanced further through regular information security assessment of various ecosystem partners.

Fraud Management System at UIDAI

UIDAI has a well-designed, multi-layer approach and robust fraud management system in place. With the establishment of forensic lab, the fraud investigation capacity of UIDAI has increased substantially.

8.2.11 Aadhaar - A Tool for Governance Reform

I. Aadhaar and Financial Inclusion

Aadhaar is a unique digital identity which remains unchanged throughout the lifespan of an individual. When linked with a bank account of an individual, Aadhaar becomes a financial address of that individual which helps to accomplish the country's goal of financial inclusion. The 12-digit Aadhaar is sufficient to transfer any payments to an individual.

Till few years ago, in order to transfer money to a beneficiary, the Government needed to know the bank account of the beneficiary along with other details like IFS Code, bank branch details etc, which are prone to changes. However, with the introduction of Aadhaar, direct benefit transfer (DBT) to an individual's bank account takes place by just using his Aadhaar number without being affected by any changes in his bank accounts. Different types of payment systems which use Aadhaar number are described below:

a) Aadhaar Payment Bridge (APB)

This is largely a Government-to-Citizen (G2C) and Business-to-Consumer (B2C) platform for remitting funds to an Aadhaar holder by just quoting his Aadhaar number. Bank account linked with Aadhaar automatically receives the funds coming through APB. Currently, some of the flagship schemes with large number of beneficiaries viz. DBTL (PAHAL), PM-KISAN, MGNREGS, NSAP, various Scholarship Schemes and TPDS etc., are transferring cash benefits and subsidies directly to the beneficiaries' bank accounts through APB.

As on 31st December 2019, 68.06 crore Aadhaar holders have linked their Aadhaar with multiple bank accounts across 980 banks including all nationalized banks, RRBs and many cooperative banks. An amount of ₹ 2,59,050 crore has been remitted so far through over 591.64 crore successful transactions. (*Data source: NPCI*).

b) Aadhaar Enabled Payment System (AEPS)

AEPS is the platform using which an Aadhaar holder, who has linked his Aadhaar in the bank account, can do basic banking transactions, including cash withdrawal, cash deposit, balance enquiry, fund transfer etc in an interoperable fashion from any Bank's MicroATMs (Point of Sale devices carried by Bank Mitras).

AEPS has transformed the way the marginalized customers were dealt with by the banks. It has empowered the customer to do an interoperable transaction on their account from any microATM in the neighbourhood, hence making the market customer driven and resulting in competition among all banks. As on 31st December 2019, 484.12 crore successful transactions have been done cumulatively on this platform across nearly 13.96 lakh microATMs. (*Data source: NPCI*)

II. Aadhaar and DBT

To achieve targeted delivery of welfare services in a more transparent and efficient manner, the Government of India had launched Direct Benefit Transfer (DBT) through Aadhaar Payment Bridge (APB) and other channels in January 2013. DBT was implemented in phases for all Central Sector Schemes and Centrally Sponsored Schemes. So far, several DBT schemes are leveraging APB to transfer cash benefits to the Aadhaar linked bank accounts of the beneficiaries. As on 31st December 2019, multiple schemes including PAHAL had paid over `2,59,050 crore across 591.64 crore successful transactions. It has been made possible by linking Aadhaar with the bank accounts of the beneficiaries. (*Data source: NPCI*)

III. Notifications issued under section 7 of the Aadhaar Act 2016 by central Ministries/ Departments for DBT Schemes

In order to use Aadhaar of the beneficiaries under various schemes which are funded from the Consolidated Fund of India, the concerned Department/Ministry administering the Scheme is required to issue a Gazette notification under Section 7 of the Aadhaar Act 2016. As per the decision of the Cabinet Secretariat, UIDAI has been mandated to facilitate the Ministries/ Departments in drafting and issuance of such notifications in compliance with the Aadhaar Act 2016, with due

vetting by the Ministry of Law and Justice. Till 31st December 2019, UIDAI has coordinated with 40 Ministries/Departments to issue 159 notifications under Section 7 of Aadhaar Act covering a total of 293 Schemes (Centrally sponsored or Central sector).

8.2.12 Implementation of Official Language Policy in UIDAI

UIDAI is implementing Official Language Policy of Govt. of India in its Headquarter as well as in its all 8 Regional Offices and ensuring the compliance of various provisions envisaged in the Official Languages Act and Official Languages (Use for Official Purposes of the Union) Rules, as well as orders of the Government of India, issued from time to time in this regard.

During the year 2019-20, (as on 31st December 2019) three meetings of Official Language Implementation Committee were held at Headquarter in which, among other items/subjects, progressive use of Hindi was discussed and decisions had been taken to increase the use of Hindi in official work. During the reporting period, two Hindi workshops were organized for sensitizing the officials with the Official Language Policies/Rules. 53 officers and staff participated in this workshops.

Progressive use of Hindi in Headquarter and all 8 Regional Offices of UIDAI was discussed and necessary guidelines were issued to the Regional offices for promoting use of Hindi as per Government directions specially for original correspondence in Hindi to Region A, B and C as per targets prescribed in Annual Program 2019-20 of Department of Official Language, Ministry of Home Affairs.

'Hindi Pakhwara' was organized from 14th to 28th September, 2019 in UIDAI Headquarter. Five competitions in Hindi were organized during this occasion. 161 Officers/employees of UIDAI Headquarter actively participated in these Competitions.

To promote use of Official Language in official work, every year UIDAI carries out an incentive scheme for noting and drafting in Hindi at its Headquarter as well as in all the Regional Offices independently. During 2018-19, five employees of Headquarter were found eligible for cash prizes as per scheme .

8.2.13 Details of Budget & Expenditure

During 2019-20 (upto 31st December 2019), an expenditure of ₹ 556.77 crore has been incurred against Budget Estimate of ₹ 1227.00 crore. Since inception, the total expenditure incurred is 11,682.13 crore.

8.3 Indian Computer Emergency Response Team (CERT-In)

The Indian Computer Emergency Response Team (CERT-In) is a statutory organisation under Ministry of Electronics and Information Technology, Government of India. CERT-In has been designated

under Section 70B of the Information Technology Act, 2000 to serve as the national agency to perform the following functions in the area of cyber security:

- Collection, analysis and dissemination of information on cyber security incidents
- Forecast and alerts of cyber security incidents
- Emergency measures for handling cyber security incidents
- Coordination of cyber security incident response activities
- Issue guidelines, advisories, vulnerability notes and white papers relating to information security practices, procedures, prevention, response and reporting of cyber incidents

Such other functions relating to cyber security as may be prescribed.

Further details are available in Chapter 6, Section 6.3.3.

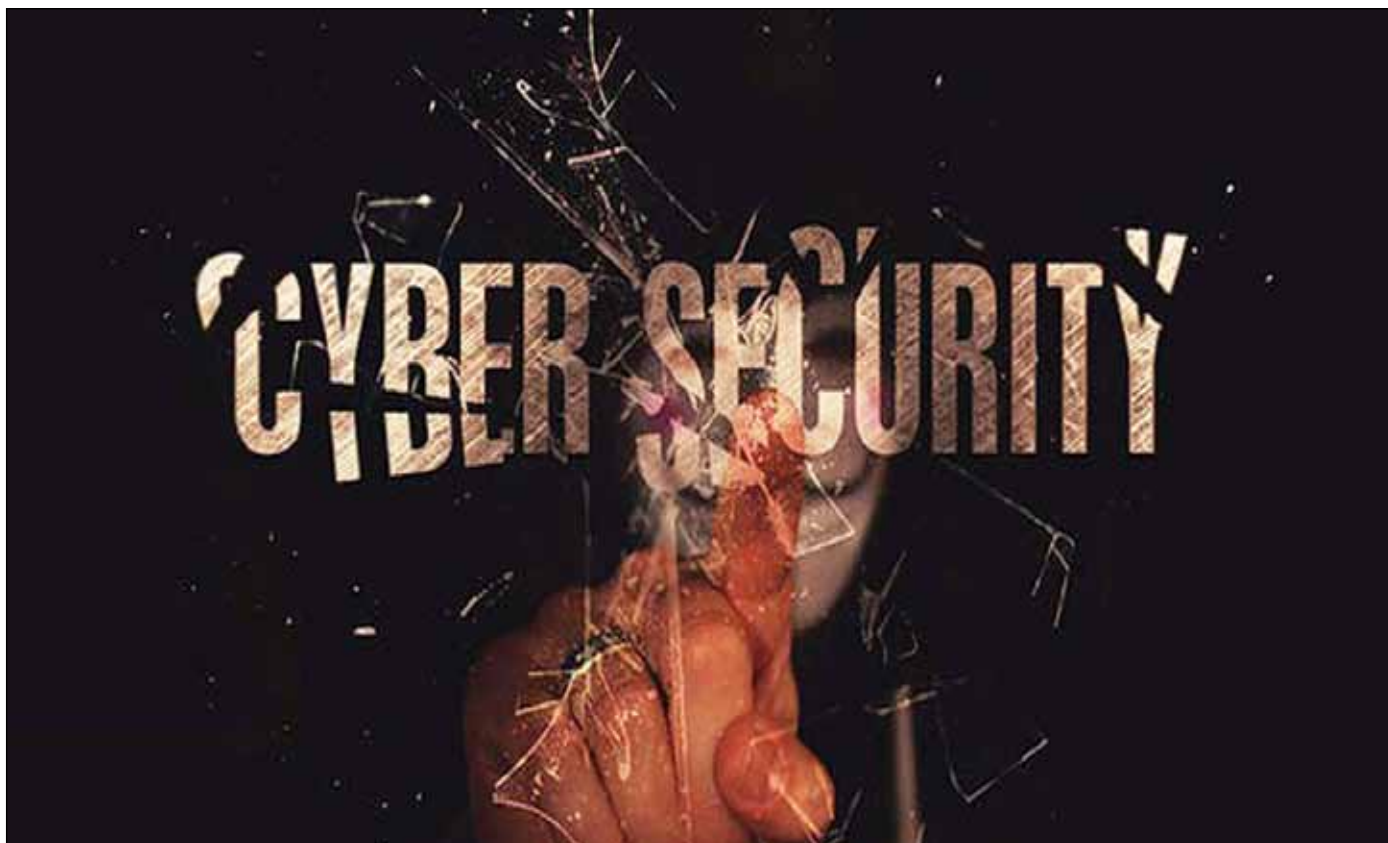

Chapter – 9

Attached Offices and Societies

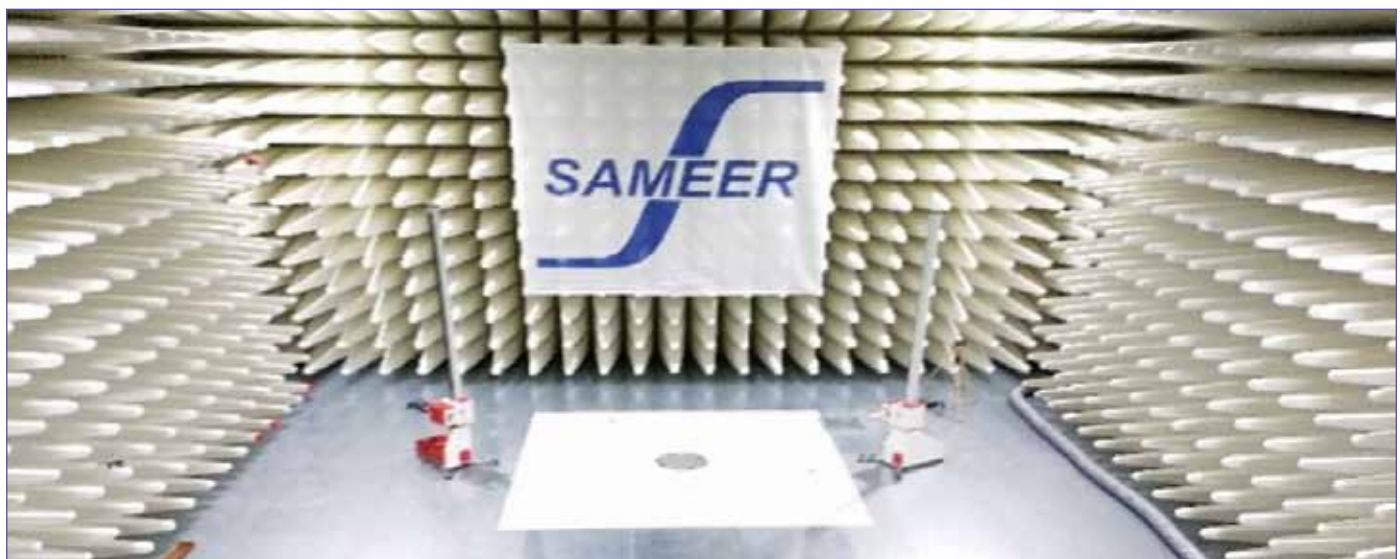

9.1 Centre for Development of Advanced Computing (C-DAC)

Centre for Development of Advanced Computing (C-DAC) is a premier R&D organization of the Ministry of Electronics and Information Technology (MeitY) for carrying out R&D in IT, Electronics and associated areas. In addition to carrying out research and development in High Performance Computing, the R&D of C-DAC expanded to various other areas such as Cloud Computing, Multilingual Computing, Heritage Computing, Professional Electronics including VLSI and Embedded Systems, Cyber Security and Cyber Forensics, Health Informatics, Software Technologies and Education related to these technologies. C-DAC Advanced Computing Training School (ACTS) is a well-known brand in the area of High-end training in Electronics and IT in the country.

During the year 2019-20, C-DAC made significant advancements in carrying out research and development in electronics and information technology, developing and deploying various solutions, collaborating with organizations of repute both at national and international level, providing trainings and organizing events etc.

Key technological achievements of C-DAC during this year in each of its focus areas are outlined below.

9.1.1 High Performance Computing (HPC) and Cloud Computing

National Supercomputing Mission

C-DAC is spearheading national research and development in high performance computing under the National Supercomputing Mission (NSM) with

participation of stakeholders within the country involved in the area. Following the successful installation and commissioning of a system with peak performance of 800 Tera Flops at IIT BHU, Varanasi, C-DAC has delivered PARAM Shakti with peak performance of 1.66 Peta Flops at IIT Kharagpur and PARAM Brahma with peak performance of 800 Tera Flops at IISER Pune under Phase 1 of NSM. One System each with peak performances of 1.66 Peta Flops at IIT Kanpur, 800 Tera Flops at IIT Hyderabad and 800 Tera Flops at JNCAR, Bengaluru are also planned to be delivered during the year 2020.

These systems are developed under 'build approach'. The major subsystems of these systems such as compute nodes and HPC network are manufactured in India in line with Make in India Policy of Government of India. The uniqueness of these systems lies in its highly efficient cooling technology, which is based on direct contact liquid cooling. The systems are installed with C-DAC System Software Stack encompassing C-Chakshu, CHReME, Ganglia, Nagios XDMoD, OSTicket, OpenHPC, Lustre, PARAVIEW, MVAPICH2, Intel Cluster Studio, GNU tools, CUDA Toolkit and others. They also have widely used HPC applications from various scientific and engineering domains, which are optimized for the architecture of the system.

For effective use of these systems, C-DAC has conducted a capsule of 5-days training at each site.

For exploration of development of future HPC systems, C-DAC has developed 100 Tera Flops pilot entry level systems each around ARM, AMD and IBM Power 9 processors. Earlier, it had developed 100 Tera Flops system around Intel processor. One system based on IBM Power9 based processor along with 200 TB parallel file system-based storage is being commissioned at C-DAC, Bengaluru. Another 100 TF cluster based on AMD processor technology is being commissioned at C-DAC, Pune.

HR development activities conducted under NSM during the year included conduction of HPC awareness programmes, Faculty Development Programmes and HPC training workshops. Faculty Development program was conducted at Walchand College of Engineering, Sangli, while HPC training workshops were conducted at IIT BHU and are planned at IIT Khargapur and IISER Pune. HPC Hackathon was held at IISER Pune in association with OpenACC and Nvidia. AI Hackathon was conducted at C-DAC, Pune in association with Nvidia. A winter school on HPC was organized in association with ACM India at IIT Kanpur. The first HPC nodal centre is planned to be setup at IIT Kharagpur.



PARAM Shakti with peak performance of 1.66 Peta Flops at IIT Kharagpur



PARAM Brahma with peak performance of 800 Tera Flops at IISER Pune

PARAM Shavak

C-DAC has developed another variant of PARAM SHAVAK titled as **PARAM SHAVAK SRISHTI** to cater the needs of bioinformatics and agriculture sector. PARAM SHAVAK SRISHTI is a table-top Supercomputing-in-a-Box solution and does not require sophisticated data centre ecosystem to operate. It is equipped with x86 based latest processor architecture along with high memory, designed to address the challenges of computation, modeling and simulation of bioinformatics and agriculture research. It is composed of hybrid computational hardware along with HPC enabled open source, widely used bio and agri applications. It is also integrated with two C-DAC's indigenous applications named Tango and Anvaya to promote R&D in the field of Bio-informatics. During the year, C-DAC continued the proliferation PARAM Shavak and its variants including **PARAM Shavak DL GPU System** and **PARAM Shavak Virtual Reality (VR) System** at various academic and research institutions across the country. C-DAC has deployed more than 100 PARAM Shavak systems across the country till date.

Implementation of 1.2PF Advanced Supercomputing System at ISRO-NARL

C-DAC signed a contract with National Atmospheric Research Laboratory (NARL) an autonomous research institute under Department of Space for turn-key implementation of 1.2 PF advanced supercomputing system with 2 PetaBytes of storage and the associated datacenter ecosystem. The contract duration is for five years where in C-DAC will also be taking care of the facility operations during the contract period. The building and commissioning of this HPC system shall be completed by the end of December 2019.

PARAM Yuva-II System at C-DAC's National PARAM Supercomputing Facility

Since its commissioning in February 2013 at C-DAC's National PARAM Supercomputing Facility

(NPSF), PARAM Yuva II has been widely used by scientists and engineers for research. PARAM Yuva II system has processed 4,10,620 Jobs till October 2019. Utilization of NPSF has always remained above 90%. Usage of NPSF's HPC services has been acknowledged in 331 publications and 52 PhDs so far. About 1179 users including 258 PhD scholars across 122 institutions executed their jobs on PARAM Yuva II for their scientific research covering a large no. of cross functional domains. More than 72 HPC applications from various science and engineering domains were ported and optimized for PARAM Yuva II. 200 TB HPC storage has been commissioned at NPSF for PARAM Yuva II user data storage.

Hackathons

C-DAC along with NVIDIA & ATOS conducted an AI Hackathon during September 26-30, 2019 at C-DAC, Pune. In this hackathon, various teams of developers worked on the problem statements provided by C-DAC and NVIDIA in AI/ML space. 11 teams were shortlisted for final participation for the hackathon. Top 3 winners were felicitated with a cash price of Rs.1,00,000/- Rs.75,000/- and Rs.50,000/- respectively. A GPU Application Hackathon (GAH-2019) was also conducted jointly by C-DAC, Nvidia, IISER Pune and OpenACC forum under the aegis of National Supercomputing Mission (NSM) during September 14 – 18, 2019 at IISER Pune.

C-DAC Automatic Parallelizing Compiler (CAPC)

C-DAC's automatic parallelizing compiler (CAPC) is an innovative software that can make a traditional C program to be parallelized and run on any multi-core CPUs as well as GPUs. It adapts the program to parallel multi-many cores / GPUs and makes it run faster on these devices; it makes a C language program to be portable across different architectures. This software is of great value to the developer community and novice parallel

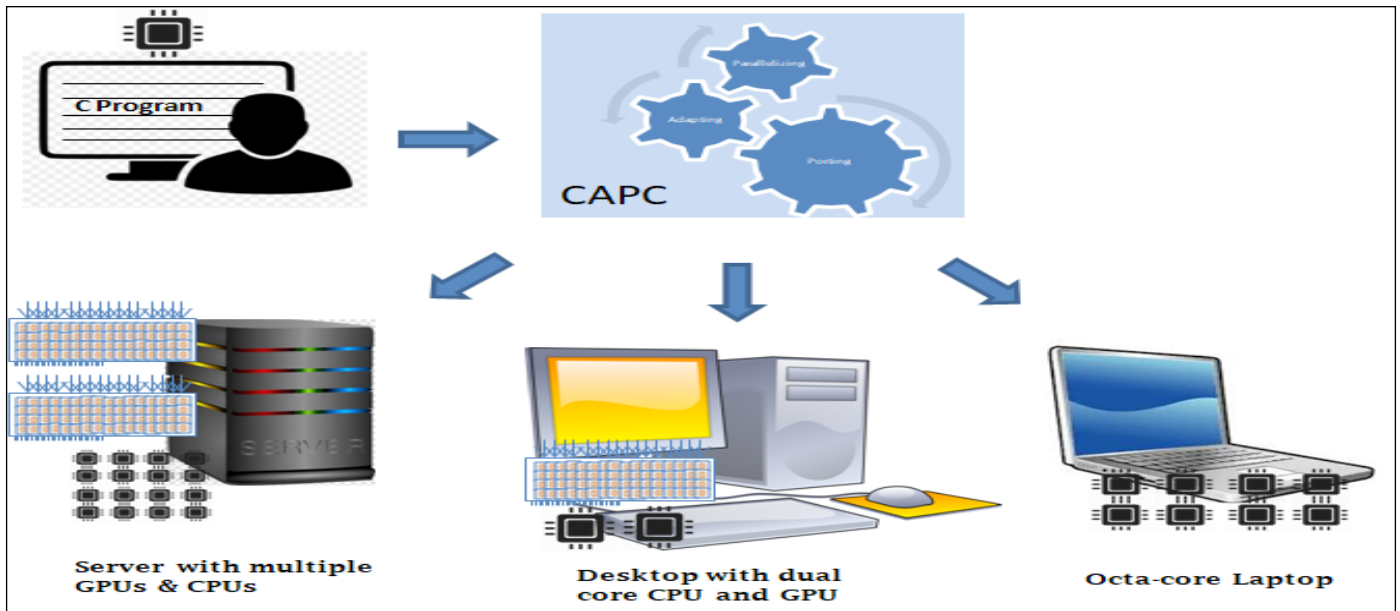

C-DAC's Automatic Parallelizing Compiler

programmers, as they can jumpstart by using their C programmes on the latest parallel architectures.

SuParikshan – Supercomputer Monitoring & Management

The NSM supercomputers are large heterogeneous systems composed of several hundreds of nodes with CPU and GPU compute elements, storage devices and high-speed cluster interconnect networks. It is a challenging task for System Administrators to ensure that all these components are healthy because errors / degradations in any of the components will prove costly for the scientific jobs. SuParikshan is an in-house solution developed for monitoring the health of all the components of HPC cluster supercomputer. SuParikshan is engineered to be light weight, extensible, accessible from anywhere over the web and provides intuitive visual interface for easy detection and rectification of any problems in the cluster. It monitors critical hardware, software, power, user jobs, etc., provides email escalation of critical alerts, card based graphical analyser, configuration and custom scripts execution for administrators.

Panorama Phase II

Marine Forecast Visualization System has been awarded to C-DAC on successful completion and deployment of Panorama Phase I. This initiative is funded by Naval Research Board, DRDO. It is a GIS based marine weather decision support system. It can process numerical weather and ocean state global and regional forecast output, global observations and satellite images to aid the naval operations at sea. It shall enable user-friendly on-board 2D and 3D visualization of atmosphere as well as ocean forecast for 10 days. This automated system shall facilitate real time data download from multiple sources, database management, state of the art data compression, multi-parameter visualization, extreme event analysis, alerts and real time data dissemination to ships sailing across the globe.

Bioinformatics

Personal Health Train for Radiation Oncology in India and the Netherlands

C-DAC is working on an initiative called “personal health Train for Radiation oncology in India and

the Netherlands (TRAIN)” that unites academic, industrial and clinical leaders to improve care for cancer patients via Big Data science. TRAIN focuses on head and neck cancer, which is a societal challenge both in India and the Netherlands due to its disappointing outcomes, practice variations, high incidence and the level resources needed for diagnosis and treatment. TRAIN will address this challenge by the introduction of Decision Support Systems that can predict which treatment leads to an optimal outcome given the individual patient characteristics and local diagnostic and treatment capabilities.

Molecular Tailoring Approach for predicting structures of large molecules on HPC Clusters

C-DAC is working on an initiative that aims at predicting structures of large molecules using Divide and Conquer approach named as MTA (Molecular Tailoring Approach). The objective of this initiative is to make this HPC application available to the user community through PSE (Problem Solving Environment) developed by C-DAC.

9.1.2 Professional Electronics, including VLSI and Embedded Systems

Microprocessor Development Programme (MDP)

“Microprocessor Development Programme” has been approved by MeitY and is being executed by C-DAC over two phases. Phase-I of the project has been completed, which involved microarchitecture design, development and verification of the 64-bit Quad core Processor (comprising of 64-bit superscalar out-of-order RISC-V Processor core with FPU, L1 Caches, MMU, Coherent Interconnect, Interrupt controller and L2 Cache). The 64-bit Quad core Processor has also been validated on an FPGA platform, Linux booted and benchmark programmes and image processing applications viz. face detection, object detection,

etc. have being executed. Phase-II of the initiative involving design, implementation and fabrication of SoC ASICs based on the 64-bit Processor targeting embedded applications is in progress. A full ecosystem including hardware boards, device drivers and software will also be made available.

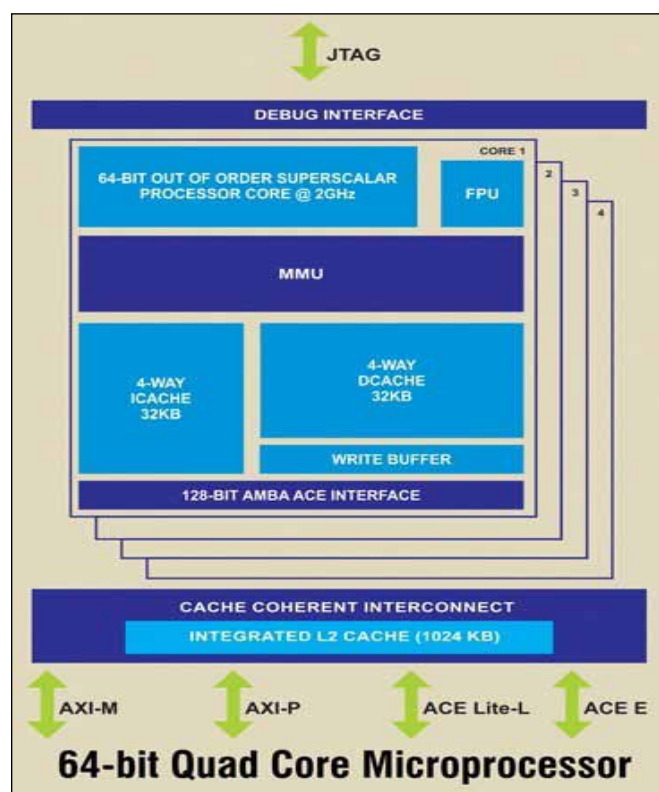

Microprocessor Development Programme (MDP)

Emergency Response Support System

Emergency Response Support System (ERSS) (erstwhile NERS) is an integrated system that provides a common platform to receive distress signals in the form of voice, message, email, panic signal etc. and to dispatch various services such as Police, fire rescue and health. The common single number 112 is designated for this purpose. C-DAC has signed an MoU with Ministry of Home Affairs (MHA), Govt. of India for the development and deployment of this system across the country. Installation of ERSS / 112 App has been completed in 27 states till date. 35 States/UTs are planned to be ready with ERSS by March 31, 2020.

Commercialization and Deployment of TARANG

C-DAC has developed TARANG - Digital Programmable Hearing Aid (DPHA). Industry partners have sold more than 70,000 units of Tarang through various channels. Government of Kerala has approved distribution of TARANG Hearing Aids under various schemes of Local Bodies in the state.

National Common Mobility Card (NCMC) Ecosystem

Automatic Fare Collection System (AFC) and Validation Terminal is designed as an interoperable fare management system which provides a solution to the passengers/commuters while transit in all kinds of transportation. The Automatic Fare Collection system Swagat (Gate) and Sweekar (Software for control, fare collection and settlement with banks) has been jointly developed by C-DAC and BEL with support from DMRC, NPCI and SBI under guidance of MoHUA. NCMC Ecosystem pilots at Delhi Metro Rail Corporation (DMRC), Bengaluru Metro and Centralized AFC System and Pilot Deployment at BEST, Mumbai and other PTOs are under progress. Interoperability testing of NCMC cards between Delhi and Noida Metros, Release of updated Interface Specification of NCMC Ecosystem V1.1 and development of specification for QR Code base Ticketing Solution etc. are also under progress and are likely to be completed during the year.

Smart Energy Meter

Smart Energy meter developed jointly by C-DAC and BEL, Bengaluru, is targeted for single phase domestic segment. It enables automated reading of meters and helps enhanced load predictions. It's a 1-P (1 Phase) 2 Wire meter enabled with C-DAC's own Device Language Message Specification (DLMS) stack, Pluggable communication module supporting NB-IoT/2G (Narrow band - IoT), Wi-Fi, BLE (Bluetooth Low Energy), 6LoWPAN (IPv6 over Low Power Personal Area Network), Optical port

support, OTA (Over The Air) support, Automated Load control, Tamper Detection, Integrated Security and Net metering support. Currently the system (including PCB, Enclosure) is being tested for performance and stability against the required features. The Conformances w.r.t BIS standard requirements are planned in near future along with the revision of the design.



DLMS Enabled Energy Meter

Smart Water Distribution System

Smart Water Distribution System consists of storage tanks with level sensors, motorized control valves to modulate the water flow, flow sensors to monitor the flow of water in the pipeline, pressure sensors to monitor the water pressure at some critical points in the distribution line and finally end user with on/off control valve and flow meter to monitor the amount of water consumed. The signals from the sensors are processed with the custom designed signal conditioning PCBs and are currently linked through 6LoWPAN/Cellular based wireless sensor nodes. Server and dashboard applications have been developed to process the data received from the sensor nodes for water billing and analysis.

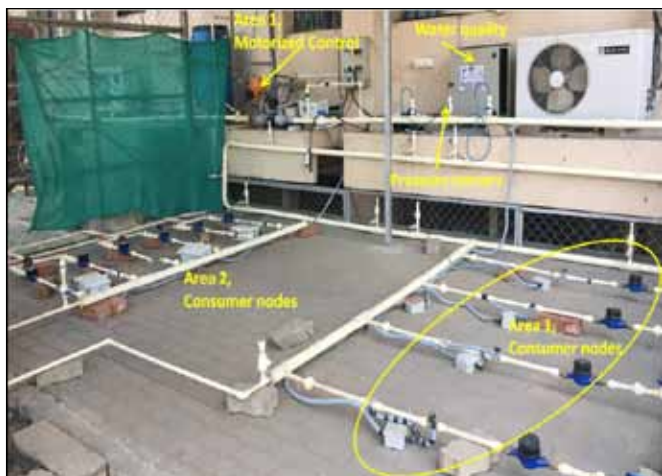

Water testbed deployed in C-DAC Bengaluru premises

Indoor Air Quality Station

The indoor air quality station is meant for primarily monitoring indoor comfort. The unit is Wi-Fi enabled, compact and wall mountable. The parameters that are monitored include Carbon dioxide, PM2.5, PM10, ambient temperature and relative humidity. A mobile App displays the data from the unit.

Outdoor Air Quality Station

The outdoor air quality station is meant for monitoring the concentration of primary air pollutants at various instants of time during the day. The device monitors air pollution data and sends it to the remote server for data logging and analysis. The device is equipped with the primary air pollutant sensors such as Carbon Monoxide (CO), Nitrogen Dioxide (NO₂), Sulphur dioxide (SO₂), PM10, PM2.5, Temperature and Relative humidity for measurement and analysis of air quality. The air quality data is displayed in the form of Air Quality Index (AQI) in a web/mobile application.

Airport Terminal Building – Indoor Environment Quality

Wi-Fi enabled devices that monitor indoor environment quality parameters such as PM2.5, PM10, Carbon dioxide, light intensity, temperature and relative humidity are planned to be deployed at

various locations in Chennai airport domestic terminal building. This would be useful in performing indoor comfort analysis for airport terminal buildings and a framework would be developed as a support model for other airports too. This work is being jointly done by C-DAC and IIT Roorkee. IIT Roorkee would develop building architecture analysis models.



Wideband RF module at V/UHF band (VUHF TXRX)

Wideband RF Transceiver module has been indigenously designed for Software Defined Radio (SDR) applications and is capable of operating in the frequency range of 2 MHz to 2 GHz. This Transceiver module supports frequency hopping up to 500 Hops per second.

Agriculture Quality Assessment Solutions

AmyloSens (An instrument for measurement of Amylose content of rice)

Measurement of Amylose content in rice is an important chemical which represents the cooking quality of rice. Presently it is measured by chemical analysis followed by visual inspection which is subjective, time consuming, non-repeatable and depends on human perception. A voltammetric method for measuring Amylose percentage



AmyloSens

of rice has been developed. The system uses a combination of electrode array and virtual instrumentation-based data acquisition and data analysis in order to quantify rice on the basis of Amylose content.

AnnaScan (An instrument for measurement of cooking quality of rice)

Rice quality is commonly characterized by its physical and biochemical attributes. The physical attributes are size, shape, color, odor profile, texture, whereas, alkali spreading value (ASV), amylose content (AC), gel consistency (GC) & grain elongation of rice grain are considered as biochemical attributes. Alkali spreading value of rice represents the gelatinization temperature (GT) which is partly associated with the amylose content of the starch and has a negative correlation with cooking temperature of rice. A system has been developed using a portable flatbed scanner backed up by digital image analysis technique running on a computer. A new measurement index (Spreading Index) has been developed for calculating the extent of ASV of the rice grains. The developed machine vision solution eliminates manual dependency and reduces the measurement time.

Apple^{Sense}

An instrument has been developed for measurement of the quality of apple by fusion of appearance-based property (size, colour and texture) using digital image analysis technology and the measurement of firmness using non-destructive acoustic technology. The acoustic response (sound) is generated by hammering the apple at different position on its surface and the signal is acquired using a condenser microphone. The acquired acoustic response is processed through computer using advanced digital signal processing techniques. Specific signal features in time and frequency domain are extracted from the acoustic response. Finally, a mathematical prediction model

is deployed to estimate the firmness of apple based on the extracted signal features.

Litchi Grading System

A continuous type grader namely Litchi Grading System has been developed for grading Litchi fruit based on FVGMR and AGMARK criteria using E-Nose and E-Vision hybrid system. E-Nose module only accepts or rejects litchi based on the aromatic component present in litchi and the E-Vision module identifies each grade of litchi based on predefined criteria i.e. color and size mentioned in international standard.

FUMON (Fumigation Monitoring System)

Fumigation Monitoring System (FUMON) is a handheld device that would measure the concentration of Phosphine in the crop stack during fumigation process without manual intervention at certain intervals of time. FUMON device will automatically sniff fumigant from the stack under fumigation at certain interval. Using this device, the expert can see the Concentration-Time (CT) product (ppm-hrs) plot online in real time and can understand the efficacy of fumigation and accordingly can lengthen or shorten the duration of fumigation. The system has been tested and deployed at Food Corporation India, Raipur for rice storage depot.



Fumigation Monitoring System (FUMON)

Warehouse Management System (WMS)

WMS is all about managing a warehouse in an efficient and cost-effective way by monitoring the quality of the inbound, stored and outbound grains and to minimize storage loss. Wide variation of temperature and RH in a Warehouse can cause damage of the stored grains. Monitoring of these two parameters at various points of the grain stack is a primary requirement. C-DAC has developed a system that enables FCI to have a firsthand information of the variation of these parameters and take corrective measures to save the stored grains from getting damaged. The Annadarpan device developed by C-DAC can give quality attributes of rice, parboiled rice and wheat based on their visual parameters.

Robotics in Agriculture

The usage of robots in agriculture may be useful to reduce the operating costs and lead time of agriculture. C-DAC is carrying out an initiative for developing a battery powered Autonomous Robotic Platform to perform complex operations of paddy farming i.e. sowing of seeds using direct seeding technique, monitoring of crop health, spraying of pesticides, weedicides and fertilizers. The solution uses the state-of-the-art image processing and machine learning technologies. AI based guidance and navigation system (UWB, Visual odometry, Geo fencing and IMUs) will be developed. Development of Human Machine Interface (HMI) located at the base station will be used by authorized operators with access to cloud dashboard. All the data will be communicated via inbuilt communication module to the farmers and research institutions through cloud.

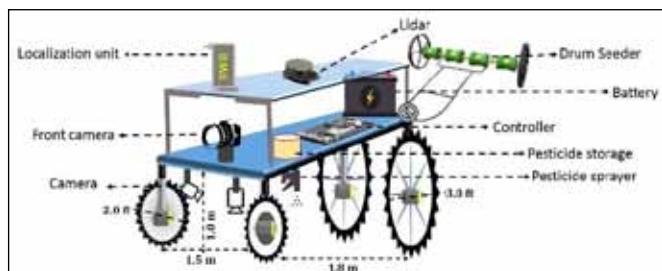

Proposed Robotic Platform

Intelligent Transportation System (ITS)

New R&D projects have been initiated collaboratively with IIT Bombay, IIT Madras & IISc Bengaluru in InTranSE (Intelligent Transportation System Endeavor for Indian Cities) Phase-II program, as an extension of InTranSE Phase-I program funded earlier (2009-12) by the MeitY. The following R&D projects were initiated in June 2019 and the development activities are in progress:

- Promoting Road Safety through Deployment of Driver Assistance and Warning System
- Development of a Bus Priority System at Signalized Intersections using V2I Communication
- Departure Time Planner using Vehicle to Vehicle (V2V) and Vehicle to Infrastructure (V2I) Communication
- Data-driven Models and Decision Support Tools for Improved Transit Reliability in Indian Cities
- Development of Smart Vision Sensors for Industrial and Road traffic applications
- Development of Common Service Layer based on Global standard for Intelligent Transportation Systems
- Development of Desktop-Based Driving Simulator for Non-Lane Based Mixed Traffic System

Commercialization of Adaptive Traffic Control Systems and Emergency Vehicle Priority System

Implementation of Adaptive Traffic Control System for Smart city deployments using WiTraC (Wireless Traffic Control System), TraMM (Traffic signal remote Monitoring and Management) software, CoSiCoSt (Composite Signal Control Strategy) software are being carried out by TOT partners across various Indian cities. These products were developed through Grant in Aid (GIA) funding

from MeitY in InTranSe Phase-I program. The commercial implementation of Emergency Vehicle Priority System (EmSerV) for providing priority green signal for ambulances at traffic signal junction are being discussed with various Smart City Corporations & City Authorities.

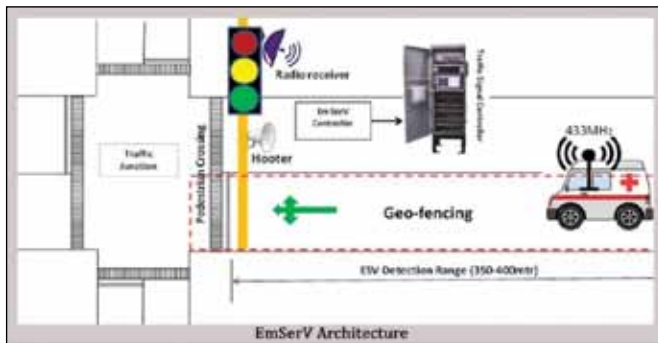

Emergency Vehicle Priority System

National Roll out of Vehicle Tracking Solution – Suraksha Mitr

C-DAC has designed, developed and implemented AIS 140 based vehicle tracking and monitoring platform named “**Suraksha-Mitr**” for Kerala Motor Vehicles Department (KMVD). This platform is compatible with the AIS-140 standards mandated by MoRTH (Ministry of Road Transport and Highways). This vehicle tracking and monitoring platform was launched in Kerala on October 16, 2018. As of November 2019, nearly 34,000 vehicles in Kerala are monitored under this system and a greater number of vehicles are being connected to the system. The prime objectives of Suraksha-Mitr are to enhance the safety of passengers (especially women passengers) in public passenger vehicles with the provision of panic button and integration with ERSS (Emergency Response and Support System) and to support the transport department for enforcement activities such as over-speeding, trip-curtailment etc.

National Mission on Power Electronics Technology (NaMPET)- Phase III

NaMPET is a mission programme involving

research, development, deployment/ demonstration and technology transfer for commercialization of Power Electronics (PE) technology, infrastructure and awareness creation, implemented through a network of Academic Institutes, R&D laboratories and Industries with C-DAC as the Nodal Centre. NaMPET Phase III activities have been started in Feb 2019 for a duration of 5 years. Main focus areas include Microgrid for Villages, Green Energy Community buildings, Deployment of Wide Area Monitoring (WAM) systems, Empowering e-mobility ecosystem, Smart Power Quality Centre in Distribution Grid, High Voltage Power Electronics for “FAITH” (Food processing, Agriculture, Industry, Health), Consortium for New Horizon in Power Electronics (PE) Technology, Exploratory Research Projects from Academic and R&D Institutes and Awareness Creation, International Interaction, Technology marketing and Promotion of Start-ups etc.



NaMPET- Phase III

9.1.3 Multilingual Computing and Heritage Computing

GIST-Mail

Gist-Mail is an AI powered Internationalized Emailing System- which is multilingual, multimodal and secure system. It is compatible with various E-Mail clients on Mobile and Desktop such as Thunderbird.



Features of Gist Mail

<https://www.gistmail.in/or> <https://जिस्टमेल.भारत>

Localization Projects Management Framework (LPMF)

Localized 50+ Govt. of India websites using C-DAC's LPMF in 6 to 10 major Indian languages. 100+ Govt. of India website data crawled and made available for crowdsourcing through gotranslate.mygov.in. Deployment of C-DAC's Go-Translate Localization Framework, Transliteration services from www.gisttransserver.in, Keyboards, GIST-Namescape tool for name comparison for Govt. of Andhra Pradesh has been carried out. The framework is now hosted in AP data centre / equivalent. It has been integrated in 100+ Andhra Pradesh State Government portals including the Chief Minister's Dashboard.

National Roll out of e-Services of Election Commission of India (ECI)

Under this project, citizen services and services for ECI officials have been developed and deployed. The citizen services are available under National Voters Services Portal (NVSP) and it provides services like national electoral search, information related to polling booths and electoral rolls. ERO Net provides a decision support workflow and system for ECI officials. It provides services for electoral roll management, form processing, monitoring dashboard, alerts & notifications and maintaining the health of electoral roll. ERO Net 3.0 with new features has been developed and deployed for all the states. During this year the Elector's verification Programme (EVP) was launched for citizens and ECI officials and services were offered on NVSP, EVP portal, Booth Level Officer (BLO) Net app

and Voter Helpline app. More than 75 crore electors have been verified under this initiative. The Electronic Transmitted Postal Ballot System (ETPBS) developed under this project has been used in General Election and State Elections of 2019.



National Voters' Services Portal

Cloud based NLP Services

C-DAC has developed cloud based Natural Language Processing (NLP) services using AI and ML under one umbrella.

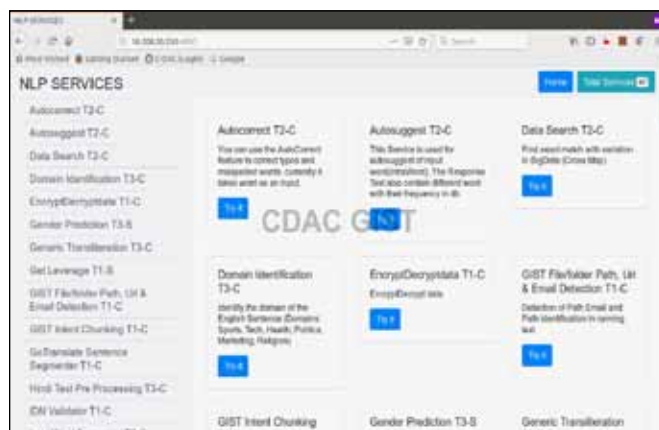

Cloud based NLP Services

Cloud NLP services offers various services such as Spellchecker, Sentence Similarity, Transliteration, Auto-complete, Synonym, Named Entity Recognition, Gender prediction, Text compression, Intent Chunking, Synonyms, Sentence Analysis and Sentence on web.

Hindi to English Machine Translation System for Judicial Domain

This initiative aims at designing, developing and deploying Machine Translation (MT) System from Hindi to English language for judicial domain. It is targeted to deliver a web-based hybrid MT system with the development of different linguistic factors such as morphology, NE, PoS, WSD etc. C-DAC is contributing towards System Deployment and Client-side support in Hon'ble Supreme Court, High Courts and NALSA.

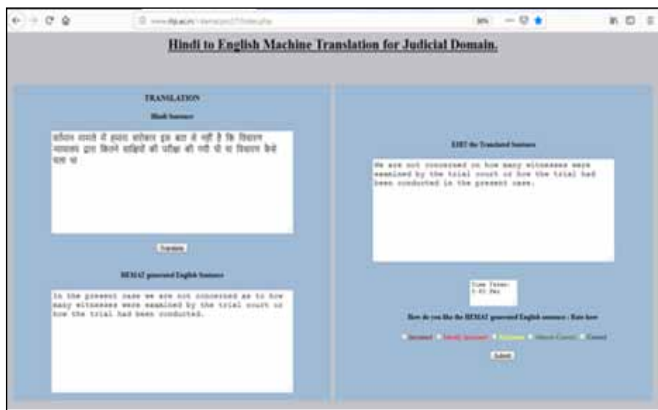

Hindi to English Machine Translation System for Judicial Domain

e-Mahashabdkosh on Mobile

e-Mahashabdkosh on mobile is a domain based bilingual and bidirectional English-Hindi pronouncing dictionary (on Android and iOS devices). e-Mahashabdkosh on mobile contains the Hindi equivalent terms of English root words and vice-a-versa. The details of words include description in Hindi as well as English along with usages and pronunciation of the root words. This mobile Apps can be downloaded from Google's Play store for Android devices and from Apple's app store for iOS devices.

LILA Hindi Pravah

LILA Hindi Pravah is a Web and Mobile based intelligent self-tutoring system for Hindi specially designed for people who wish to learn Hindi. This

initiative was sponsored by Department of Official Language (Rajbhasha Vibhag), Ministry of Home Affairs, GoI. The courseware of Hindi Prabodh, Hindi Praveen and Pravah are included in the package which is made available to all free of cost. LILA Hindi Pravah can be accessed through Internet from the website (<http://lilahindipravah.rb-aaai.in>), while the mobile apps can be downloaded from Google's Play store for Android devices and Apple's app store for iOS devices.

Translation Memory- कंठस्थ

"Translation Memory-Kanthasth" developed C-DAC and funded by Department of Official Language [DOL]. A translation memory (TM) stores previously translated source and target words, sentences and paragraphs into an electronic file. It stores the section of text, called a segment, which was translated previously and then repurposes it when the same or similar segment is identified by the TM. Multiple Workshops for 'Kanthasth Training' were conducted during Year 2019 at different places such as Delhi, Pune and a large number of members from various Government departments, Banks & PSUs participated in Workshops.



Kanthasth Workshop

9.1.4 Health Informatics

Deployment of e-Aushadhi Drug Warehousing Solution

C-DAC's "e-Aushadhi" is a web-based Supply Chain Management System for the distribution

and supply of drugs and vaccines in the healthcare system of the country. As per mandate for Nationwide rollout from the Ministry of Health and Family Welfare (MoHFW), Government of India (GoI), C-DAC's e-Aushadhi is currently operational in 18 States. The solution has also been implemented under 5 national programmes of the MoHFW.

Deployment of e-Sushrut - Hospital Management and Information System

C-DAC has indigenously designed and developed the "e-Sushrut", a full-fledged Hospital Management Information System (HMIS). The solution provides an indispensable mechanism for digitizing & streamlining the workflow of hospital services and is a major step towards adapting technology to improve healthcare. Currently, the solution has state-wide presence in Rajasthan and pilot initiatives are underway in the states of Maharashtra, Andhra Pradesh, Telangana and Odisha.

e-RaktKosh - Blood Bank Management System

e-RaktKosh is a comprehensive national portal to address the problem by providing means to collect, disseminate, standardize and streamline the standard operating procedures and guidelines of blood banks across India. Currently more than 2800 blood banks in 32 States / UTs across the country have been on-boarded into the system.

Telemedicine Solutions

eSanjeevani – Integrated Telemedicine

C-DAC's eSanjeevani flagship telemedicine solution has been selected by Ministry of Health and Family Welfare, Govt. of India for PAN India rollout at 1.55 Lakh Ayushman Bharat- Health and Wellness Centres (AB-HWCs). eSanjeevani is an indigenously developed telemedicine solution with in-built video conferencing & wireless import of test results & physiological parameters. This telemedicine solution has been deployed at around 100 locations in India and 40 locations overseas.

Mercury™ Nimbus Suite

C-DAC offers "Mercury™ Nimbus Suite", a cloud-deployable/cluster-able comprehensive Telemedicine solution to deliver healthcare services to remote areas and exchange EMR of individuals between remote and specialty end along with other telemedicine options while also providing tools for maintaining lifelong EHR. Mercury™ Nimbus solution is being utilized under Odisha eICU and Telemedicine Network and National Thermal Power Corporation (NTPC) Telemedicine Network.

Strengthening of Onconet India project in the State of Kerala

C-DAC has designed, developed and implemented the initiative "Strengthening of Onconet India project in the State of Kerala" with funding from the Ministry of Health and Family Welfare, Government of India. The end-users of the project are Regional Cancer Centre (RCC), Trivandrum and its peripheral remote Early Cancer Detection Centres (ECDC) such as ECDC (Malabar Cancer Care Society) Kannur, ECDC Palakkad, ECDC Kaloore–Ernakulam, ECDC Wayanad and ECDC Kozhenchery. The major activities completed as part of this initiative are

- Developed and deployed telemedicine software with embedded Video Conferencing facility. Developed and deployed a Smartphone-based population-screening app for cancer.
- Upgraded the "Sanjeevani" Mobile Tele-Oncology Unit (implemented with MeitY funding in 2010) with facilities like Digital Mammography Unit, Immunology Analyzer, Haematology Analyzer and Portable Colour Doppler Ultrasound unit
- Upgraded the medical equipment in the five Early Cancer Detection Centres of Regional Cancer Centre (RCC) in Kerala
- Established fibre optic leased lines connectivity to nodal and remote centres

Mobile Oncology System for Cancer Control Activities in the state of Karnataka

C-DAC has designed, developed and implemented Mobile Oncology System for Cancer Control activities in the state of Karnataka, named as ASHAKIRAN for Kidwai Cancer Institute (KCI). The initiative was funded by Bharat Electronics Limited (BEL) with an objective to support the people by identifying and treating the diseases in the early stage itself to increase the chances of survival. Telemedicine software is integrated with the Mobile Oncology System. The mobile medical unit has been set up for visiting rural areas, which will be immensely helpful for aged and economically underprivileged people in far-flung areas. The mobile medical unit comprises of all necessary medical equipment along with medicines, which can provide diagnostic information for treatment of any disease.

Mobile Telemedicine System for Tribal Care, Wayanad

C-DAC and Sree Chitra Tirunal Institute for Medical Sciences & Technology (SCTIMST) Thiruvananthapuram have designed, developed and implemented Mobile Telemedicine System to provide telemedicine facility with specialist consultation to patients in tribal areas of Wayanad district of Kerala through two Mobile Telemedicine Units with Comprehensive EMR and Telemedicine software. The two Mobile units will be visiting the



Mobile Telemedicine Bus for tribal care at Wayanad, Kerala

Primary Health Centres (PHC) of Wayanad district at scheduled regular intervals. Patients can avail expert consultation from the specialist hospital using video consultation and sharing EMR through the Telemedicine application.

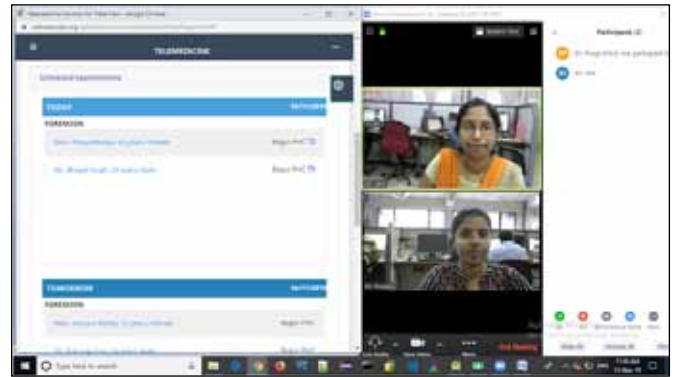

Teleconsultation schedule and Videoconferencing

C-DAC’s Medical Informatics Standards Software Development Kits

C-DAC’s Medical Informatics Standards Software Development Kit (SDK) v1.0 for Continuity of Care Document (CCD) is an implementation of HL7 / ASTM CCD Release 1 standard in healthcare applications. CCD R1 is an XML-based standard which provides a “snapshot in time” constraining a summary of the patient’s clinical, demographic and administrative data. This SDK is a standardization effort in continuation to the earlier developed SDKs for HL7, DICOM and SNOMED CT health informatics standards by C-DAC.

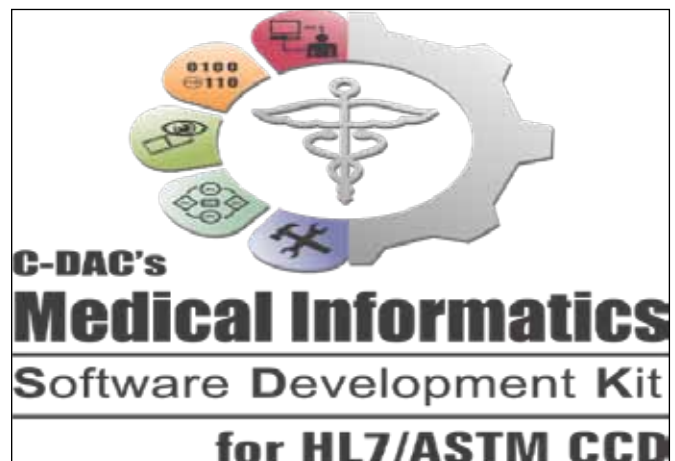

Setting up of National Resource Centre for EHR Standards (NRCeS)

Ministry of Health and Family Welfare (MoHFW), Government of India has established a Centre of Excellence named as National Resource Centre for EHR Standards (NRCeS) at C-DAC Pune to accelerate and promote adoption of EHR standards in India. The six chosen functional areas under the initiative are Training and Promotion, Tools Development, Implementation Support, National Releases and Extensions, Liaison with Standards Organization and Advisory and Consultation. NRCeS has issued 56 affiliate licenses for use/incorporation of SNOMED CT healthcare terminology this year bringing the total to 433 for India. During the year, 5 workshops, 8 training programmes, 5 events and talks have been conducted under NRCeS program where 843 people have been trained or sensitized for adoption and use of EHR standards. With this NRCeS has been associated with health IT community covering around 115 organizations and more than 5000 Individuals through events, workshops, trainings, support, software and resource utilization etc.

Common Drug Codes for use in India

In order to support standardized coding of medications in Electronic Health Record, NRCeS will be releasing Common Drug Codes in November 2019 for trial use. The common drug codes will cover generics and brands from 3 major national programmes including National Essential List of Medicine (NLEM), Jan Aushadhi and Affordable Medicines and Reliable Implants for Treatment (AMRIT) programme. These common drug codes will be bundled in multiple ways to allow users to use them independently as well as integrated with Terminology. The use of common drug codes across all healthcare systems will promote drug prescription and identification safety, reduce entry errors, reduce use of local codes and numerous maps between them. The common codes when integrated with terminology can be used to trace taxonomy, refer in research and decision support systems.

C-DAC's Medical Informatics Standards Software Development Kits

C-DAC's Medical Informatics Standards Software Development Kit is a suite of object-oriented API

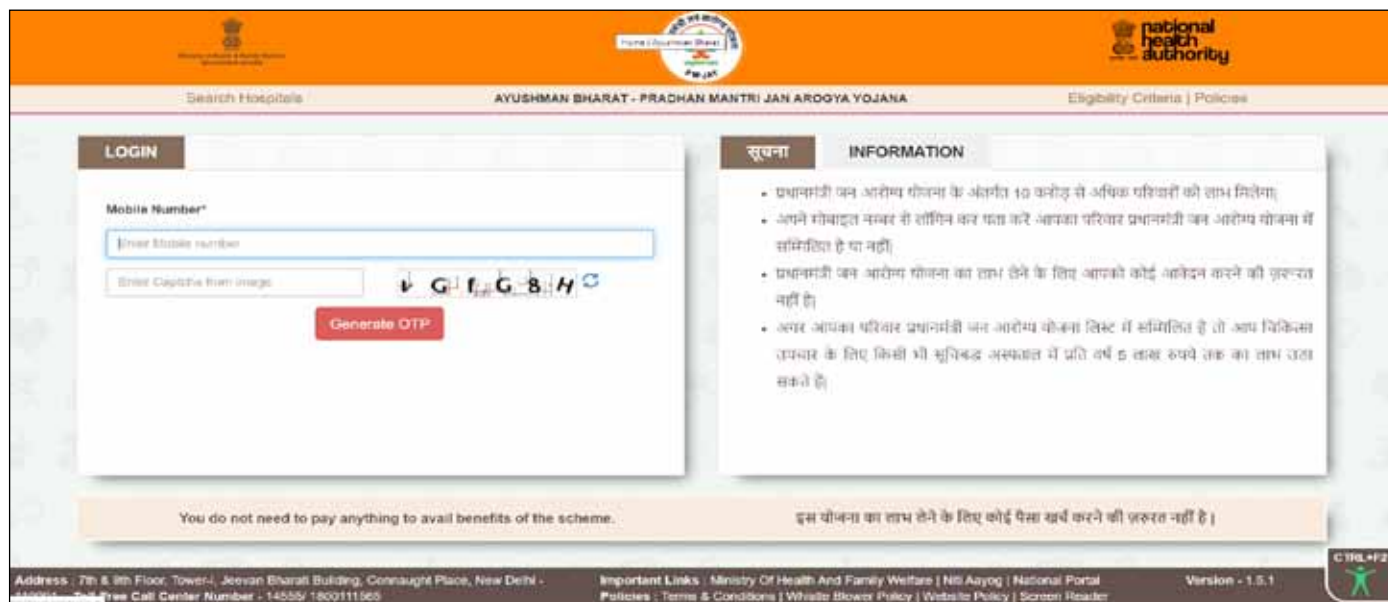

Ayushman Bharat, a National Health Protection Mission

class libraries, sample tools, documentation and other related tools that provide medical standards compliance to the implementing applications/medical devices. The SDK toolkits include C-DAC's Medical informatics SDK for CCD v1.0 released on April 05, 2019 and C-DAC's Toolkit for SNOMED CT (CSNOtk) v5.5 was released on November 22, 2019. The toolkits are open-source, free-to-use and specially designed for easy access and integration in healthcare applications and devices.

“Am I Eligible” Search Portal for Beneficiary Identification System

C-DAC has delivered a Search services to National Health Authority (NHA) to facilitate online searching of family members and beneficiary's data (approx. 57 crore entries) covering 36 States and UT's of India. The features of the service include phonetics search, auto-suggestion, regions / numerological variants, name splitter and sequence, trimming, etc. to provide ease to use search under Ayushman Bharat, a National Health Protection Mission (AB-NHPM). The project is funded by National Health Authority (NHA).

9.1.5 Cyber Security and Cyber Forensics

Live-Virtual-Constructive (LVC) hybrid testbed

Live-Virtual-Constructive (LVC) hybrid testbed has been developed to overcome the limitations of either physical, simulation, virtualization or emulation for Supervisory Control and Data Acquisition (SCADA) testbed. Physical testbeds are based on replicating existing SCADA systems and Simulated testbed is through modelling the SCADA system through simulated environment. However, it is difficult to obtain high fidelity from simulated systems when exploits and vulnerabilities in the systems need to be modelled. In LVC based hybrid testbed approach, SCADA components have either been replicated physically, virtualized, emulated or simulated. This is to present a realistic testbed for cyber security purposes.

AI based Digital Forensic Platform:

C-DAC in collaboration with IIT Patna is working on a project titled “Development of C-DAC Digital Forensics Centre with Artificial Intelligence based Knowledge Support Tools” funded by MeitY & Govt. of Bihar. As part of the project C-DAC Digital Forensic Lab (DIGIFAI) is being implemented at BISCAMAUN Bhawan, Patna, Bihar. Cyber Security related training programmes are being conducted for different categories of Government and non-Government agencies to support the Law Enforcement Agencies. Project team has undertaken the problem-oriented research activities in the area of digital forensics and implementing an AI based Knowledge Support Toolset namely DIGIFAI Toolset which contains three major modules:

- Machine Learning Based Text analytics Tools (DIGITEXT)
- Image Processing Based Document Forensic Tools (DIGIDOC)
- Monitoring of Violence and provoking Activity in Cyber Space (DIGIMONITOR)

The Alpha version of all the above three modules has been developed and is planned to be completed and implemented at C-DAC DIGIFAI Lab by March 2020.

Information Security Education and Awareness (ISEA) Phase- II

Under ISEA Phase-II, 1.14 lakh persons are proposed to be trained under formal and non-formal courses and faculty training. In addition, about 400 paper publications are expected. The initiative also aims to provide training to about 13,000 Government officials and creating mass information security awareness targeted towards academic users, Government users and general users (approximately 3 crore internet users through direct and indirect mode). 52 institutions comprising of IISc Bengaluru, 6 IITs, 15 NITs, 5 IIITs, C-DAC/

NIELIT Centres, 5 Technical Universities and 7 Government Engineering Colleges have been identified for the implementation of academic activities under the initiative.

So far, 2,76,394 candidates have been trained/under-going training under various formal/non-formal courses through 52 institutions including 2,20,135 candidates in affiliated colleges of 5 Technical Universities participating in the initiative. In addition, institutions have reported more than 700 technical paper publications. Additionally, 8,603 Government officials have been trained. Under the awareness component, 1029 awareness workshops have been conducted covering 1,33,990 participants in direct mode. Multilingual awareness material on information security has been designed and disseminated through these workshops, print/electronic/digital mode and multilingual portal. So far, 11 cyber security awareness weeks were organized in collaboration with state/district police departments. Cyber security curriculum designed for 3rd to 12th standard has been submitted to CBSE/NCERT for adoption and 1,473 school teachers have been trained as master trainers. 20 editions of bi-monthly newsletters and 1 Annual Magazine have been published. 57 programmes have been broadcasted through Doordarshan/All India Radio on various cyber security related topics. More details can be found at www.isea.gov.in and www.infosecawareness.in.

Cyber Forensics Lab Setup for Law Enforcement Agencies

C-DAC is engaged in research and development of Cyber Forensics Tools, Cybercrime analysis and setting up of Cyber Forensics Labs for Law Enforcement Agencies. The Cyber Forensics tools include CyberCheck Suite for disk forensics, MobileCheck for mobile forensics, WinLiFT for Windows Live Forensics, NetForce Suite for Network Forensics and Advik CDR Analyser. C-DAC has also released the Digital Evidence

Management System (DEMS) software, as a Forensic lab management software. The other hardware tools include True Imager for forensic imaging of disks, SIMXtractor for SIM card analysis and TrueTraveller, the portable forensic field kit. C-DAC has supplied nearly 255 copies of these indigenously developed cyber forensics tools to various Law Enforcement Agencies across the country. C-DAC also has a cybercrime analysis lab and supports the Law Enforcements Agencies in the country in analysing digital evidences and providing expert testimony in courts.



True Traveller Field Kit



True Imager Disk Imaging Tool

Predicting multistage attacks using Machine Learning

C-DAC is carrying out an initiative to develop a solution to host machine learning models for predicting multistage attacks. It includes creation and enhancement of malign and benign dataset repository, evolving a setup for capturing essential parameters of attack for dataset generation and development of an engine for data transformation

and feature extraction. C-DAC has designed and built various machine learning models for predicting the malicious executable and identification of malicious flows in the network. We have got some success in identifying different stages of the multistage attacks and we are also able to map the same to MITRE ATT&CK.

Vulnerability Detection in Embedded device Firmware

The objective of this initiative is to develop a solution for detecting malware (backdoors as a form of malware) in embedded devices. C-DAC identified advanced Binary Analysis approaches for detecting malware in the embedded device firmware and finalized an approach to test for the presence of backdoor vulnerabilities in a given embedded device in both the cases when firmware is not available and when firmware is retrievable and binaries are extracted in multiple domains and are complex in nature. Following applications/solutions are being evolved to tackle the above-mentioned vulnerabilities:

- USB Pratirodh solution controls the usage of removable storage media, such as, pen drives. Total number of downloads of the USB Pratirodh software is 38,980
- AppSamvid is an Application Whitelisting Software for Microsoft Windows and there are 23,301 downloads
- Browser JSGuard is a security add-on to the Mozilla Firefox and Google Chrome Browsers which protects from JavaScript based attacks. Total number of downloads are 29,986

Distributed Centre of Excellence for Blockchain Technology

C-DAC continued its efforts towards establishment of Distributed Centre of Excellence for Blockchain Technology during the year. Blockchain Technology based Property Registration Management System has been piloted for the Shamshabad District of

Telangana State Government. A generic Proof-of-Existence (PoE) Framework has been developed as a spin-off solution and is being implemented for student certificates. Blockchain based Cloud Security Assurance solution is currently being developed.

Security Testing and Validation Methodologies for Cryptographic Module

Designed and developed side channel resistance AES implementation as a case study to qualify on the methods mentioned in ISO/IEC 17825 standard. An automated Test Vector Leakage Assessment environment to capture, pre-process and analyze from the Device under Test/Assessment has been developed. These implementation and framework can be used to evaluate and carry out leakage assessment of crypto modules. Formal modeling languages have been explored and their applicability to FIPS 140-2 testing methodology was done and applied these modeling languages for developing formal model of security framework for PRNG-IP CORE. FIPS 140-2 compliant software / hardware of NIST listed algorithms and random number based custom test vector generation for NIST algorithms were also designed and developed.

9.1.6 Software Technologies, including Free and Open-Source Software (FOSS)

Electronic Project Proposal Management System (e-PPMS):

e-PPMS is a web-based system designed and developed for Science and Engineering Research Board (SERB) that encompasses the complete life-cycle of funding of R&D projects, beginning with online submission of project proposals, to monitoring and management of funded project. During the year, new schemes of SERB were incorporated. These include Startup Research Grant, Ramanujan Fellowship, Scientific and Useful Profound Research Advancement (SUPRA), Science and Technology Award for Research (STAR), Women Excellence Award.

Some significant updates also happened during the year:

- Launch of Knowledge portal (www.imprint-2.in) for IMPRINT-2 scheme of MHRD to showcase the information of technical progress and fund utilization in the project.
- Design and development of submission module for the submission of projects for the project titled “National Mission on Interdisciplinary Cyber Physical System” (NM-ICPS).

Deployment and Proliferation of BOSS

C-DAC has carried out 5.5 million deployments of Bharat Operating System Solutions (BOSS) GNU/Linux so far for enhancing the use of Free/Open source software throughout India. It is available in 3 flavours.

e-Pramaan

For details please read chapter 2, Section 2.1.1.1

Vikaspedia - Collaborative Knowledge Sharing Portal

Vikaspedia is a MeitY initiative for providing e-knowledge and empowerment of poor (rural and urban) using ICT-based applications. It seeks to maximise utility of ongoing Government programmes through provision of universally accessible digital information resources in Indian languages, created and shared collaboratively by various development stakeholders. It is multi-lingual, multi-sectoral online knowledge platform - www.vikaspedia.in. The portal is available in all 22 constitutionally recognized languages of the country and English. Besides, providing information related to six key livelihood sectors- Agriculture, Health, Education, Social Welfare, Energy and



Vikaspedia

e-Governance, additionally, two citizen centric information sections have been included in the portal. Vikaspedia currently hosts 9.5+ lakh pages of content shared by about 300+ institutions and 1 lakh + registered members. The portal attracts 20 crore hits per month from about 5+ million users.

Mobile Seva

Mobile Seva initiative of C-DAC enables integration of the mobile platform with the common e-Governance infrastructure consisting of SDCs, SWAN and SSDG/ NSDG and facilitates delivery of public services over mobile devices using mobile based channels such as SMS, USSD, IVRS and m-Apps. 4,365 Government departments and agencies across the country have integrated their services with this mobile seva platform and 3,013 crore push SMS transactions, 1.23 crore IVRS transactions and 17.59 lakh USSD transactions have been made.

e-Hastakshar – C-DAC’s e-Sign Service

For details please read chapter 2 , Section 2.1.1.2

Unified Portal for Employees’ Provident Fund Organization (EPFO)

C-DAC has developed a unified portal for EPFO that caters to different processes of the establishment life cycle such as registration of establishments, advance and settlement claims etc. So far, 2,78,37,455 members have been enrolled.

9.1.7 Education and Training

Post Graduate Diploma in Advanced ICTE areas

During the year C-DAC launched new courses namely Post Graduate Diploma in Artificial Intelligence (PG-DAI) and Post Graduate Diploma in Advanced Secure Software Development (PG-DASSD). C-DAC now offers 13 Post Graduate diploma courses in the following domains

1. Post Graduate Diploma in Advanced Computing (PG-DAC)

2. Post Graduate Diploma in Mobile Computing (PG-DMC)
3. Post Graduate Diploma in Embedded System Design (PG-DESD)
4. Post Graduate Diploma in IT Infrastructure System and Security (PG-DITISS)
5. Post Graduate Diploma in System Software development (PG-DSSD)
6. Post Graduate Diploma in Big Data Analytics (PG-DBDA)
7. Post Graduate Diploma in Internet of Things (PG-DIoT)
8. Post Graduate Diploma in VLSI Design (PG-DVLSI)
9. Post Graduate Diploma in High Performance Computing System Administration (PG-DHPCSA)
10. Post Graduate Diploma in Biomedical Instrumentation and Health Informatics (PG-DBIHI)
11. Post Graduate Diploma in Geo-informatics (PG-DGi)
12. Post Graduate Diploma in Artificial Intelligence (PG-DAI)
13. Post Graduate Diploma in Advanced Secure Software Development (PG-DASSD)

Comprehensive Recruitment Solution for Indian Air Force

C-DAC continued to conduct online recruitment examinations including Air Force Common Admission Test (AFCAT) for Officer’s cadre and Test for Airmen Recruitment (STAR) for Airmen cadre for Indian Air Force (IAF) with its indigenously developed series of solutions using latest technologies to bring more transparency, convenience and security in the recruitment processes. C-DAC has developed and deployed Central monitoring dashboard during AFCAT and STAR exam conducted in 2019 which enables live monitoring of the exam conduction status from the exam centre. C-DAC conducted IAF AFCAT

August, 2019 during 24-25 August, 2019 for over 1.1 lakh candidates and IAF STAR September, 2019 during 21-24 September, 2019 for over 5.73 lakh candidates across India.



Central Monitoring Dashboard for online recruitment examinations for Indian Air Force

Rollout of Olabs for schools

The initiative “Rollout of Online Labs (OLabs) for schools” being implemented by C-DAC jointly with Amrita Vishwa Vidyapeetham, Kollam, Kerala is aimed to create infrastructural and support framework for making OLabs accessible and usable by students and teachers across India and train approximately 30,000 teachers in effective use of



Online Labs (OLabs)

OLabs resources to enhance the teaching learning experience. OLabs is available for public access at www.olabs.edu.in. For OLabs Offline, OLabs Live bootable DVD and OLabs Windows Installer is available and is updated periodically with the website dump. So far 27,287 CBSE teachers have been trained from 7,976 CBSE schools across India.

Process Automation for Competitive Exams

C-DAC has designed and developed process automation system for competitive exams that provides automation of candidate registration, online application filling, application scrutiny, centre allocation, hall ticket issue, answer-key verification, answer key challenge, result processing and analysis, score generation, choice filling and seat counselling. This has been used for GATE (past 8 years), JAM (past 6 years), AIIMS (2 year) and NBE (2 year). The system handles approximately 13 lakh applicants every year. During the year, this system is being used for automation of GATE/JAM 2020 for IITs and IISc, Post-graduation, MBBS and nursing seat counselling for All India Institute of Medical Science (AIIMS) and DNB, Post MBBS and Post Diploma Centralized Merit Based Counselling for National Board of Examinations (NBE).

Pradhan Mantri Gramin Digital Saksharta Abhiyaan (PMGDISHA)

C-DAC continued to participate in PMGDISHA program as assessment and certifying agency. PMGDISHA is a central government’s initiative of digital literacy program in the country. The aim of the initiative is to make at least one person in each household digitally literate to interact with digital world such as digital payment and e-Government services. C-DAC centres have started this operation since November, 2017 and have examined more than 15 lakh citizens across the country from April, 2019 to November, 2019.

9.1.8 North-East Initiatives

Significant activities carried out by C-DAC for NE regions during the year are listed below:

Resource Centre for NE Police and Capacity Development on Smart Device Forensics

The aim of this initiative is to create a Smart Device Forensics Resource Centre at North Eastern Police Academy (NEPA) Shillong and train manpower on Smart Device Forensics to deal with Smart Device Forensics investigations. Three levels of training shall be provided comprising Awareness, Beginner and Master levels. 500 resources shall be trained in Awareness level, 100 in Beginner level and 50 in Advanced level. Development of Course content/material for Smart Device Investigation is under progress and a training programme was held at NEPA for NE Police and other police during July 18-19, 2019. Total 85 people were trained during this programme.

Forest Fire Detection System and Pilot Deployment in NE Region

The main objective of this initiative is to detect forest fire in real time with the help of wireless sensor network and drone. Developed solution will be used for monitoring the forest environment 24/7, detect outbreak of forest fire and shall disseminate the information in real time to forest officials. This will help the mitigation team to act promptly. The key features of this solution include near real time 24/7 monitoring of environmental parameter in forest, near real time forest fire detection, Dashboard for data visualization, Alert generation and dissemination etc. Pilot deployment of the solution is planned in NE region.

ICT Solutions for India's North East Heritage

C-DAC has organized National Seminar on "ICT Solutions for India's North East Heritage on September 25, 2019 at North East Hill University (NEHU), Shillong. The seminar received

participation from over 25 museums, archives and heritage institutions from various North Eastern states such as Assam, Manipur, Arunachal Pradesh, Meghalaya, Sikkim and Nagaland. Technology solutions being developed under this initiative namely North East Heritage Portal, JATAN Software as a Service (SaaS), Mobile Tourist Guide, Visitor Tracking System, Antiquity Tracking System and pilot of SMART Museum Exhibit were showcased during the event.

9.1.9 International Initiatives

Various activities carried out during the year including setting up of centres of excellence and computer labs in various countries as listed below:

- Setting up of a sustainable IT Infrastructure for Advanced IT Training using conventional, virtual classroom & e-Learning technologies in Phnom Penh - Cambodia
- Setting up of a sustainable IT Infrastructure for Advanced IT Training using conventional, virtual classroom & e-Learning technologies in Vientiane - Lao PDR
- Setting up of Centre of Excellence in IT at Cairo – Egypt
- Setting up of Centre of Excellence in IT at Casablanca – Morocco
- Upgradation of existing IT Infrastructure and development of Integrated Web Based Office Automation System & Portal at CARICOM Secretariat in Guyana and Offices in Barbados & Jamaica
- Setting up of Centre of Excellence in IT in Port Moresby - Papua New Guinea
- Centre of Excellence in IT at Georgetown – Guyana
- Extension of IMCEITS in Myanmar as ATC of C-DAC for 3 years
- Setting up of Centre of Excellence in IT in Alofi - Niue

- Setting up of Centre of Excellence in IT in Suva - Fiji
- Setting up of Centre of Excellence in IT in Nauru
- Setting up of Centre of Excellence in IT in Rarotonga - Cook Islands
- Setting up of Centre of Excellence in IT in Apia - Samoa
- Setting up of India – Namibia Centre of Excellence in ICT & HPC in Windhoek
- Training of trainers from CEIT in several countries' setup by C-DAC under ITEC
- Supply of 150 Desktops Computers & Associated Software to Sao Tome & Principe
- Setting up of NexGen Centre of Excellence in IT at Amman - Jordan
- Capacity building in Research, Development & Innovation in ICT & Electronics through The Ghana-India Kofi Annan Centre of Excellence in ICT (AITI-KACE)

9.2 Society for Applied Microwave Electronics Engineering and Research (SAMEER):

9.2.1 Laboratories and Core Competence

Society for Applied Microwave Electronics Engineering & Research (SAMEER) is an autonomous R&D institution under the Ministry of Electronics and Information Technology, Govt. of India. SAMEER has five centres located at Mumbai, Chennai, Kolkata, Visakhapatnam and Guwahati.

Mumbai Centre – Centre for Microwave Research (CMR) specialises in the areas of Medical Electronics, Radar Instrumentation, Atmospheric Instrumentation, Signal Processing, High Power Radio frequency and Microwave Components and Systems, and Photonics.

Chennai Centre – Centre for Electromagnetics (CEM) specialises in the areas of Antennas,

Communications and Electromagnetic Interference /Compatibility (EMI/EMC). It is also involved in research and development in the areas of RF & microwave communication, digital signal processing, antennas and electronics packaging. As a new initiative, second campus of SAMEER-CEM at Perungudi, Chennai has been built to establish Electronics Design Centre (EDC) for realizing System on Package (SOP) has been set up in.

The Centre at Kolkata – Centre for Millimeter wave Technology specializes in the areas of Antenna and Millimeter wave technology. It is involved in the development of RF, Microwave and Millimeter-wave (MMW) components, sub-systems and systems for various users in the country. The centre has established a state-of-the-art millimeter wave laboratory with test, measurement, simulation, fabrication and assembly facilities and a Compact Antenna Test Range (CATR) facility for evaluation of antennas, radomes and scattering study with support of the MeitY at its second Campus of SAMEER, at Salt Lake, Kolkata.

NABL accredited EMC test and measurement facilities have been established at Mumbai, Chennai & Kolkata and offers comprehensive test, consultancy, training, engineering and research services to national agencies and electronics industries in India.

Centre for Electromagnetic Environmental Effects (E3), Visakhapatnam specializes in a variety of capabilities, ranging from box level to complete system level testing to cater to the increasing requirement from the strategic sectors.

Centre for High Power Microwave Tubes and Components Technology established at the Campus of Indian Institute of Technology, Guwahati for development of high power microwave tubes/components as well as research and development activity for design and development of magnetrons and circulators at GHz.

- **Indigenous Magnetic Resonance Imaging (IMRI)”**

The project is being implemented by SAMEER, Mumbai as nodal agency with C-DAC (Trivandrum), C-DAC (Kolkata), IUAC (New Delhi), DSI-MIRC (Bengaluru) as collaborating agencies. **Objective of the project is to design, develop and test an indigenous 1.5 Tesla MRI system for medical imaging.** To achieve the objective, indigenous development of subsystems of MRI like superconducting magnet assembly, coils, receiver and transmitter, image visualization module, image reconstruction module and pulse sequences have been undertaken. Indigenous RF Power amplifier chain and spectrometer have been developed and tested. RF amplifiers are generally outsourced by most of the MR OEMs.



Development of surface coils, head birdcage coil and knee birdcage coil has been completed by SAMEER. Surface coils and Birdcage coils have been integrated with GE Magnet and images have been obtained from the phantom and fruits.

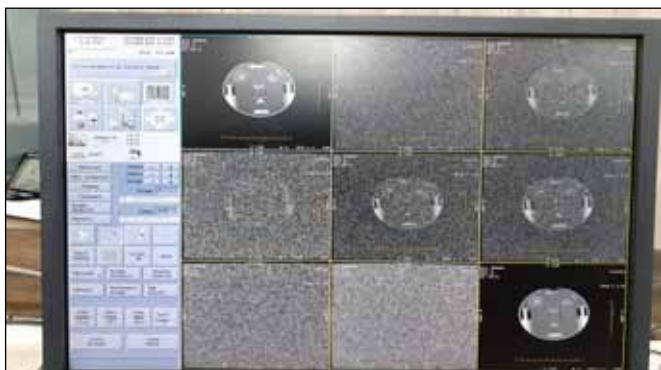

Image from 2kW RFA and Birdcage Coil (Top left Image: SAMEER Head Coil and GE Amplifier, Middle row right most Image with T/R switch between our Amplifier and Coil, Bottom right Image: SAMEER Amplifier with Gate switching circuit, T/R switch and Coil)

Platform independent pulse sequences have been developed in-house and played on GE and Siemens scanners by CDAC-T. The control circuits have also been developed by SAMEER.

Software for image reconstruction and visualization by CDAC- Trivandrum and Kolkata have been developed and integrated.

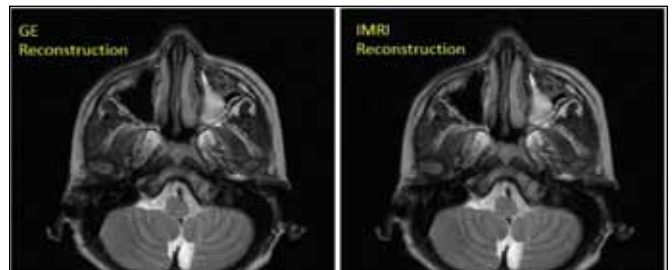
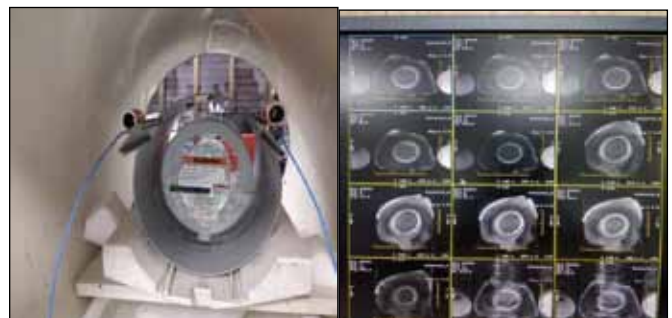

Image Validation

The superconducting magnet is the critical component of MRI and involves magnet design, bobbin winding & fabrication, integration of magnet with cryostat, cryocooler & other components. IMRI superconducting Magnet design has been completed by IUAC and its components have been developed and tested. Fabrication of bobbin and winding has been initiated.



1Head Birdcage Coil inside Mock Bore

Tender Coconut Images

Image from 2kW RFA and Birdcage Coil (Top left Image: SAMEER Head Coil and GE Amplifier, Middle row right most Image with T/R switch between our Amplifier and Coil, Bottom right Image: SAMEER Amplifier with Gate switching circuit, T/R switch and Coil)

The sub-systems developed under the project would be integrated first with the commercial magnet and then with IMRI magnet being developed at IUAC. Therefore, at the end of the project there would be 2 MRI scanners instead of the earlier proposed one scanner under the project.

Smart Warehouses with Application of Frontier EM & Electronics based Technology (SAFEETY)”

Objective of the project was Development of Smart Warehouses using EM and Electronics based technology for Food Processing and Safety.

The project was implemented by SAMEER, Mumbai as nodal agency with C-DAC (Kolkata), and IIFPT (Thanjavur) as collaborating agencies. The project was successfully completed and the systems developed under the project were installed and calibrated at FCI, Raipur in July 2019. FCI officials were also trained for operating the system. Final Acceptance test procedure was carried by FCI Manger (QC) on 23rd July.

The conveyer system and its sub-components including unique number generation module, printing, online moisture meter, weighing was developed and tested at SAMEER Mumbai.

The conveyer system along with its subcomponents was transferred at FCI, Mumbai for filed trails and rigorous testing.

The conveyer system along with its subcomponents was transferred from FCI, Mumbai to IIFPT Thanjavur for calibration.

At IIFPT Thanjavur Online moisture meter was calibrated and validated for rice and wheat against two different packaging materials for accuracy and repeatability. Accuracy of the system was determined by calculating standard deviation between AOAC reading and online moisture meter reading. It was found that less than 0.75 which implies that accuracy of the online moisture meter is ± 0.75 . Repeatability is calculated by Statistical analysis of obtained moisture content data using one-way analysis in SPSS software and it was found 100%.

The entire converized system was shipped back to FCI Borivali after successful calibration of its sub components at IIPT, Thanjavur. Field trials of the entire system were again conducted at FCI, Borivali

The system was transferred to and installed at FCI Raipur in the month of January 2019. Sub components like online moisture meter, weighing scale and printer along with RF id was installed at Raipur successfully. Rigorous testing of each system developed under the SAFEETY project was done at FCI Raipur.

Full scale trails using Truck unloading was carried out multiple times at Raipur. The unloading takes 22 mins and it was repeatedly tested at Raipur.

Annadarpan, Fumon and WMS were also successfully developed and installed at FCI, Raipur simultaneously.

Specialized Electromagnetic Pulse (EMP) Test system

MeitY has approved this project for national importance, which covers specialized Electromagnetic Pulse (EMP) Test system establishment, which is unique facility in the country to address critical Infrastructure protection against EMP, to qualify defense electronics systems as per the EMP requirements.

All defense/Civilian organisations awaiting for this unique facility to meet compliance and design assistance for both import and indigenous products, as, at present, waivers have been given EMP facility to suppliers. Worldwide different nations have given prime importance to this EMP threat and made their own resource readiness for threat posed by counter countries. Given the importance of this need, U.S parliament recently approved 2017 National Defense authorisation Act to address all critical Infrastructure sectors protection against EMP.

This facility is very important for defense sector of the country and ensures satisfactory performance of strategic hardware. The evaluation and design services provided by this center, which are currently available only at limited overseas, will not only ensure safety against import security threat but also save foreign exchange.

EMP TEST FACILITY: India's largest outdoor RS105 EMP test facility is completed and system validated for compliance testing for RS105 as per the MIL standards with generated test levels of upto 50 kV/m and covering the EUT test volume of

17m(L)X12m(W)X3m(H) , sufficient to test the large defense and civilian systems. It has been opened for serving the industries.

Pulsed Current Injection (PCI): Pulse current injections (PCI) acceptance testing is used to demonstrate that electrical Point of Entry (POE) protective devices perform in accordance with the transient suppression / attenuation requirements of MIL STD 188-125-1&2. The PCI tests require high energy Pulse generators for delivering current pulses either directly or through coupling devices in the cables.

UltraWide Band Test (UWB) Facility: UWB refers to a high power electromagnetic (HPEM) threat for electronic and computer systems. UWB test system is designed to assess the immunity of electronic equipment against high intensity and very fast electromagnetic pulses.

EMI/EMC TESTING LABORATORY: The centre has established an excellent MIL Standard test facility conforming to the requirements of the tests as per 461E/F and 464 upto 40GHz. The center has got exclusive test instrumentation comprising of



Final Acceptance test procedure was carried by FCI Manger (QC) on 23rd July.



Training program conducted for FCI officials from 01/07/2019 to 06/07/2019 for system handling.

Image from 2kW RFA and Birdcage Coil (Top left Image: SAMEER Head Coil and GE Amplifier, Middle row right most Image with T/R switch between our Amplifier and Coil, Bottom right Image: SAMEER Amplifier with Gate switching circuit, T/R switch and Coil)

various generators, loop antenna, power amplifiers, current probe, and injection probe to perform the tests. The test facilities will be extensively utilized by the industry serving the defense sector.

3D Modelling and Analysis Laboratory: 3D Electromagnetic Simulation software allows simulation and analyses of the electromagnetic behavior of electronic circuits and components to study its intra & inter electromagnetic interference scenarios to evaluate compatibility of the products. They also mimic the standard EMI/EMC testings as per different national and international standards.

Qualification of Indigenously developed HEMP POE Filters

Qualification of indigenously developed (EMI solution, Pvt Bengaluru) point-of_entry (poe) protection hemp fitters for electromagnetic pulse(emp) using pulsed current injection test facility as per mil-std-188-125-1&2 SAMEER, CE3 is the first and only laboratory in the country where DRDO/BEL has approved testing of Point-Of_Entry (POE) protection hemp fitters for Electromagnetic Pulse(EMP).

EMI/EMC Consultancy for Advanced Light Weight Torpedo (ALWT) designed and developed by Ms/ NSTL, DRDO Lab:

Study of ALWT system for identifying EMI gap areas Suitable rectification suggestions without changing major design considerations. EMI Qualification testing is carried out at NSTL facility after retrofits implementation to qualify the system for EMC compliance.

ASSESSMENT of UIDAI Data CENTRES FOR EMP Threat

UIDAI approached for Assessment and evaluation of their critical infrastructures, HDC at Bengaluru and MDC at Manesar, Haryana centre for Electromagnetic Pulse attacks. SAMEER proposed the action plan for assessment and evaluation of

the data centres against the EMP attack. As part of the assessment, SAMEER CE3 carried out the measurement activity “Measurement of ambient Radio Frequency levels within and outside of the data centers for Shielding Effectiveness measurement and recommendations for EMP compliance”.

EMP Consultation Works for Indian AirForce:

Indian Air-force is building 10 Large Blast Proof Chambers (9 Under ground and 1 Above the ground) at strategic locations accross the country. Consultant work for “proof reading and vetting of all design documents & drawings including certification of work of Electro Magnetic Pulse (EMP) of 9 under ground & 1 over ground blast proof specialised RCC integrated structures for tpical work” has been awarded to SAMEER Visakhapatnam by M/s TCIL Ltd. All the Design Documents, QTP documents and Data sheets were critically reviewed and vetted.

- Carried out Shielding Effective measurements of RF Shielded Chambers of ETS at GARC Chennai.
- Initiated 3D EM Modeling for antenna placement and coupling analysis for on-board ship for VIK-SANDWICK Pvt Ltd Chennai.
- Qualification of 500KVA DG set of M/s sterling generators India pvt ltd. for radiated emission and susceptibility measurements as per mil-std 461E

Skill Development Programme

One of the major objective of this centre is to develop pool of skilled manpower in the area of EMI/EMC through regular workshops, seminars and other educational & academic events. As part of the training and academic activities, Internship for Graduates from local colleges for a period of 1month was conducted and 200 students from many colleges attended and were benefited by the programme. Research Activities in the following

highly Specialised areas are on going :

- Electromagnetic Pulse (EMP) Hardening
- Electromagnetic Modeling to simulate and analyse the electromagnetic behavior of complex electronic circuits and components.

X-band Field Target Radar Simulator System (FTRSS)

This is a sponsored project from a Govt. R&D lab, under Ministry of Defense. The objective of this project is an application oriented research and development of a prototype of the Radar Target Simulator System. The X-band system shall simulate and mimic the behaviour of an active radar with scanning abilities, which will act as a target for a missile. It will have the ability to auto-track the missile and generate the necessary path correction factor. A prototype of the FTRSS has been developed. It's individual components have been realised and their measured performance are satisfactory. System level integration is under progress.

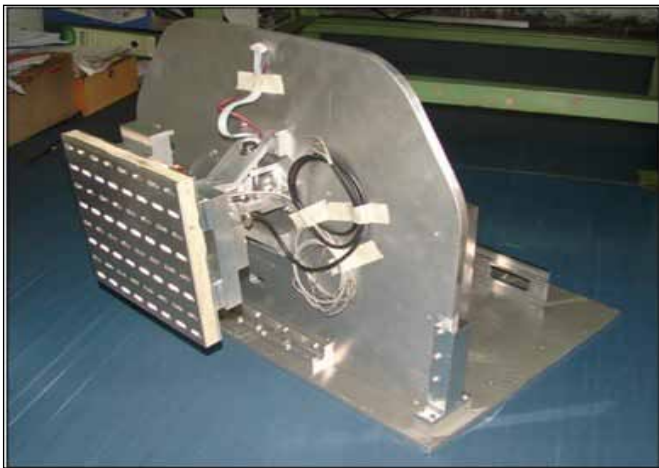

Bench level set-up for the FTRSS prototype.

S-band Ship-Borne Reconfigurable Receiving Antenna

This project is sponsored by Government R&D lab. The objective of this project is the indigenous design and development of an S-band telemetry antenna

system in which the 3dB beamwidth of its main beam can be reconfigured between $45^\circ \times 45^\circ$ and $80^\circ \times 80^\circ$. The antenna has the ability to excite left and right hand circular polarization simultaneously. A prototype of the antenna has been fabricated and performance evaluated. The measured results are satisfactory. The system assembly is under progress.



Fabricated S-band Reconfigurable Telemetry Antenna.

W-Band Coherent Transceiver with Two Receiver Channels

This design and development project is sponsored by Government R&D lab. The objective of this project is the indigenous design and development of a 2-channel W-band coherent transceiver system, which finds application in the RF frontend of various short range radars. One of the 2-channels is dedicated for the sum-signal, whereas the other channel is time division multiplexed between the azimuth and elevation differences. All the necessary and critical components have been indigenously designed and developed at SAMEER, Kolkata. Frequency multipliers, amplifiers, oscillators are to name a few of them. Receiver gain of 55 dB with a noise figure lower than 11 dB has been realised. One QT (Qualification Test) unit has been developed, experimentally demonstrated and delivered to the end-user.



Perspective view of the developed W-band transceiver

X-band Data Link RF Transmitter and Receiver

This design and development project is sponsored by Government R&D lab. The objective of this project is to design and develop transmitter and receiver for X-band data link in ASTRA missile. The transmitter unit generates 20W of CW power. With the aid of a suitable digital signal processing unit, 40 different transmission frequencies can be generated each of 20 MHz instantaneous modulation bandwidth. Starting from a 70 MHz IF signal, the X-band signal is generated by means of 2-stage of up-conversion. Employing a GaN based power amplifier, the required output power is produced. Two CEMILAC qualified transmitters have been developed.

The receiver section, down converts the X-band frequency to IF frequency at 70 MHz using two stages of down conversion. It has a dynamic range of 60 dB with constant output power of +4 dBm. Noise figure as low as 2.5 dB, with a conversion gain of 100 dB have been realized. Identical with the transmitter, 40 different frequencies with instantaneous bandwidth of 20 MHz can be selected using a digital signal processing. Six receiver units have been developed with the required electrical performance. Out of these, 4 units are SOFT and CEMILAC qualified.

(a)

(b)

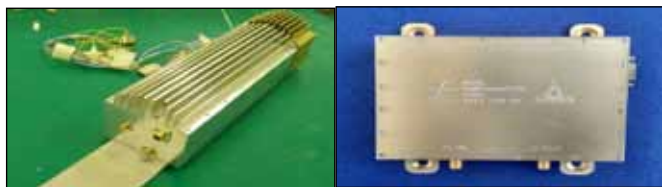

5G Developments demonstration to Hon. Prime Minister

X-band data link units, (a) transmitter, (b) receiver

EMI/EMC

More than 305 testing and 210 calibration assignments were carried out and 225 industries were benefited during this financial year.

NABL reassessment audit

National Accreditation Board for Testing and Calibration Laboratories (NABL) conducted reassessment audit for EMI/EMC Testing and calibration laboratories of SAMEER-CEM, Chennai during 18-19th August, 2018 and 15-16th September, 2018 respectively. NABL awarded accreditation certificates for testing and calibration with a validity up to 03.11.2020 and 22.12.2020 respectively.

Designation as Conformity Assessment Body (CAB) of Telecommunication Engineering Centre (TEC), New Delhi.

The technical capabilities of the Division, for a set of specified tests as per the latest standards/specifications, were audited by Telecommunication Engineering Centre (TEC), New Delhi and subsequently EMC Division is certified as TEC designated Conformity Assessment Body (CAB) for testing telecommunication equipments and devices.

RF channel CDMA receiver

Two RF channel CDMA receiver, which is third generation, Mark-III version of Coded Division Multiple Access receiver for a data link requirement. Nine numbers have been supplied after the successful completion of all functional and environmental evaluation.

Spread Spectrum Transmitter

Eight numbers of Mark-III version of Spread Spectrum Transmitter have been designed and developed. The Spread Spectrum Transmitters are used in the ground support system for the receivers. 3. Secured Two-way Communication system: Design and development of Secured two-

way communication system has been completed. Integration, test and evaluation are in progress for the sub systems.

Achievements

User agency has successfully conducted flight trials of Two RF Channel CDMA receiver in actual deployment conditions on 02.08.2018 and 23.09.2018.

On March 27, 2019, India conducted Mission Shakti, an anti-satellite Missile test from Dr. A P J Abdul Kalam Island launch complex. This was a technological mission carried out by DRDO. The test required an extremely high degree of precision and technical capability. Two RF CDMA Receivers designed and developed by SAMEER have been used in the Interceptor. Spread Spectrum Transmitter has been used in the Ground Transmitter system along with Antenna.

Fire Control System (FCS)

SAMEER has successfully completed installation, HAT/SAT testing and trials of Fire Control System (FCS) System in INS-Deepak.

5G testbed

SAMEER in collaboration with top Indian institutes including IITM, CEWiT, IITD, IITK, IITH and IISC is building the largest 5G testbed of the country, with the support of Department of Telecommunications (DoT) Govt. of India. This project aims to create 5G eco-space for various stake holders like: Industry, R&D organisations, Start-ups, Academia. This project will create a 5G prototype and testing platform, that will be developed under the co-operation of the participating institutes.

Achievements

As part of the 5G test bed, SAMEER has designed and developed the following:

- 5G Massive MIMO antenna systems (64 T × 64 Rx) and demonstrated (sub 6 GHz).

- Phased array antennas for 5G mm wave frequencies.
- 8×8 mm wave phased array and demonstrated phased array beam forming capabilities.
- User Equipment-RF was demonstrated for 64 QAM signals.



5G Developments demonstration to Hon'ble Prime minister

Hon'ble Vice-President of India, Shri M Venkaiah Naidu visited SAMEER VISAKHAPATNAM Centre (EMP and EMC facilities) on 29-08-2019 and congratulated the SAMEER Team for establishing highly specialised facility within short span of time.



Visit of Hon'ble Vice President to SAMEER Facility



Visit of Hon'ble Minister of MeitY to SAMEER Facility



Visit of Shri Ajay Sawhney, Secretary to 5G lab

Thermal Design of Electronics Systems

SAMEER has undertaken challenging tasks of Thermal Design of Electronic systems, wireless systems and onboard satellite electronic systems. Computer Aided Design & Analysis was carried out for prediction of temperature profile and optimization of Thermal design of electronic systems for application in strategic electronics and onboard spacecraft systems. Thermal Design solutions were provided to industry for the improvement of thermal performance by heat transfer techniques for realising field performance as well as system reliability.

Industry sponsored Thermal Design consultancy projects were undertaken for Thermal Design of X-band Transceiver System, Ka-band Power Amplifier, X-band Transmitter etc. The temperature profile of the X-band Transmitter System is shown in the Figure.

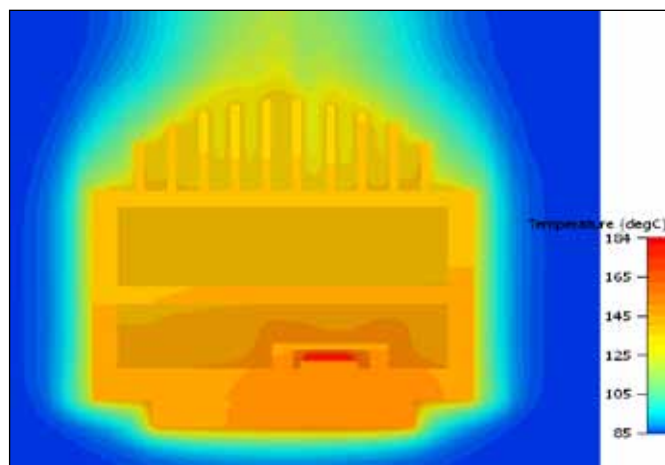

9.2.2 Major R&D Activities

Convergence, Communications & Broadband Technologies and Strategic Electronics

R&D initiatives in Convergence Communications, Broadband Technologies and Strategic Electronics are aimed at developing indigenous capability in the thrust areas which include - Next Generation Communications & Convergence technologies (Massive MIMO, Software Defined Radio (SDR), Software Defined Networks (SDN), Network Function Virtualization (NFV), Cognitive Radio, Heterogeneous Wireless Networks); Green Communication; Cyber Physical Systems, Internet of Things (IOT) & Machine to Machine (M2M) Communications, Wireless Sensor Networks; Convergence of wired/wireless networks and fixed mobile convergence; ICT applications in strategic sector; Broadband Wireless Access Technologies; Visible Light Communication (VLC), Vehicular ad-hoc Networks (VANET); IP based products/services; Electro-magnetic wave applications; High power RF/microwave tubes; Terahertz (THz) wireless systems; ST Radar Systems etc.

Convergence, Communications & Broadband Technologies and Strategic Electronics

Achievements

A number of technology development projects initiated at various institutions/R&D organisations across the country in the thrust areas were successfully completed. In the last year, next Generation Communications and Convergence have yielded in notable achievements which include “5G Research and Building Next Gen Solutions” project was implemented with consortium of 5 premier academic/research institutions collaborating to do advanced research in 5G technologies, participate in global standardization and develop advanced simulation and technology prototypes for 5G. During this period, 2 US patents and 11 Indian patents have been awarded. An advanced 5G broadband wireless simulator (BWSIM) was developed.

ST Radar for prediction of accurate weather patterns and providing warning of severe climatic conditions for NE states has been installed and commissioned at Gauhati University.



ST Radar site



T/R Module ST Radar

Some of the technologies developed/being developed indigenously under the R&D projects are as follows:

Safety Alert Systems using Dedicated Short Range Communication for on Road Vehicles (SAFEDRIVE):

As a part of the SAFEDRIVE project, On Board Unit (OBU) & Road Side Unit (RSU) hardware and DSRC Wireless Access for Vehicular Environment (WAVE) stack were developed for providing Vehicle-to-Vehicle (V2V) communication as well as Vehicle to Infrastructure (V2I) communication. The products developed would enable two-way communication that can contribute to safer driving and provide various applications that use the secure V2V and V2I communications. The field trial of the complete system has been carried out at Srisaillam Highway, Hyderabad.

Collaborative Data Processing and Resources Optimisation for Post Disaster Management and Surveillance using Internet of Things:

Developed a test bed for Internet of Things consisting IP enabled devices and heuristic solution and metric for intelligent information processing network architecture proposed a developed GUI for resource allocation, distribution, sensor live visualization, network and cluster visualization, clustering and routing algorithms. Other R&D initiatives are: Design of Robust Communication Receiver based on OFDM in Interference Limited Channels for TVWS (IEEE 802.22), Low Power Terabit for Broadband Communication Links, QoS Provisioning in Internet of Things (IoT) etc.



Road Side Unit (RSU)



On Board Unit (OBU)



On Board Unit (Mini)



RSU deployment



Drone payload

Ongoing Activity

The on-going projects supported in the identified thrust areas include Converged Cloud Communication technologies, Energy Management in Wireless Sensor Networks, Development of Unified IP based Communication Platform for Voice, Video, data, Messaging and Chat services,, Collaborative Data Processing and Resources, Big Data, Internet of Things and Cloud Computing: architecture, Issue and Application in Indian perspective, Development of National Disaster Spectrum and Disaster Communication Backbone architecture (DiCoBA) with Prototype Development, Development of Digital Mine Using Internet of Things, Design and Development of Antennas for Communication in TV White Space Frequency Band etc.-

Under Indo-Dutch collaboration for collaborative research in Pervasive Communications & computing five projects are in progress:

1. Code self-verification for IoT devices: A IoT prototype test bed has been developed at BITS, Pilani, Hyderabad Campus for intelligent decision making, prediction of events in real-time and persistent delivery of information. Tamper-proofing techniques were developed to make the life of adversaries difficult by

using Return Oriented Programming on IoT devices.

2. Operations and privacy aware smart public buildings: As part of project, a smart building testbed is being developed integrating heterogeneous sensors and communication technologies (Wi-Fi, Bluetooth, LoRa, etc.) to collect the sensed data, visualize and analyze it to learn, predict and act in accordance with desired subsystem functionality.
3. Big imaging data approach for Oncology: Big Data technology is being developed that opens up petabytes of medical imaging data stored in hospitals worldwide and use it to learn decision support systems for cancer treatments
4. Data mining & prediction in airlines: Airline Crew Pairing Optimization framework has been developed and tested for real-world airline data.
5. Crowd control Management for Kumbh Mela using Big data: Crowd Simulation on Crowd Simulator and Crowd Management Guidelines for Mass Religious Gatherings have been developed.

The promotion of R&D in the area of applied microwave electronics & engineering is being further strengthened by establishing two centres of SAMEER. Centre specializing in high power microwave tubes/ components, in collaboration with IIT Guwahati is being established. The Centre will focus on R&D of 3.1 MW magnetron at 2.998 GHz, design and development of 3 kW circulator at 2.998 GHz and 6 kW RF load at 2.998 GHz. Another Centre for Electromagnetic Environmental Effects (E3) is being established at Visakhapatnam for highly specialized state-of-the-art EMI/EMC test facilities including Electromagnetic Pulse (EMP) and Pulse Current Injection (PCI) set up to meet the requirements as per International EMC Standards. This is a unique facility in the country

to address critical Infrastructure protection against EMP to qualify defense electronics systems as per the EMP requirements. India's largest outdoor RS105 EMP test facility along with other highly specialized facilities like Pulsed Current Injection (PCI), UltraWide Band Test Facility, EMI/EMC testing laboratory and 3D Modelling and Analysis Laboratory have been established successfully.



EMP Facility

New Initiatives in the current year

Three projects in the 2nd phase of R&D collaboration between MeitY and NWO in the areas of IoT, Big Data and Emerging Technologies in ICT have been initiated. Some of new projects are: Design and Fabrication of Autonomous Passenger Drone, Acoustic Gunshot Detection System for Strategic Applications, Development of SDN and NFV based Agile Network Service Delivery Platform for Enterprise and Service, Cognitive Radio for Strategic Applications, Development of a prototype wideband RF frontend & Waveform for Spectrum Sensing based Interference Mitigation, Development of 4G/5G based UAV Augmented Intelligent Monitoring and Surveillance System, Conformal Jamming Systems for RCIED, Development of Multi-Option Proximity Sensors (MOPS) for Artillery and Mortars, Visible Light Communication based LED Lighting Solutions,

Design of Dynamic MAC and PHY SoC for Low Power and Long Range Networks, Intelligent Video Surveillance and Video Analytics System, Efficient Multicarrier Waveform Design for Next Generation Non-Orthogonal Multiple Access for Wireless Mobile Communication.

9.3 Centre For Materials For Electronics Technology (C-MET)

Centre for Materials for Electronics Technology (C-MET) was set up as a registered Scientific Society in March 1990 under the Department of Electronics (now Ministry of Electronics & Information Technology) as a unique concept for development of viable technologies in the area of materials mainly for electronics with the objectives of :

- To establish technology up to pilot scale for a range of electronic materials and transfer the same to industry for commercialization.
- To establish relevant characterization facilities.
- To undertake applied research activities in the areas of its operation.

9.3.1 C-MET's Laboratories & their Core Competence

C-MET's R & D activities have been implemented in three laboratories at Pune, Hyderabad and Thrissur. Each of these laboratories has its own area of specialization with requisite infrastructure and expertise. This approach has proven to be successful in creating core competence at each laboratory as follow:

- **Pune Laboratory:** Materials for electronic packaging, materials for renewable energy, energy storage and sensors, Nano-materials/composites, etc.
- **Hyderabad Laboratory:** Ultra High Pure (UHP) materials, compound semiconductors,

refractory metals, alloys, NABL accredited Restriction of Hazardous Substances (RoHS) facilities and e-waste processing, etc.

Thrissur Laboratory: Microwave dielectrics, substrates, multilayer ceramics, actuators and sensors, nanomaterials and thin films, aerogels & graphene based supercapacitors, Transparent Conductive Oxides (TCO) materials etc.

9.3.2 Products Developed by C-MET for different Applications

a. Products developed for ISRO under the program “Indigenization of space materials”

- Synthesis of $\text{LiNi}_{0.8}\text{Mn}_{0.1}\text{Co}_{0.1}\text{O}_2$ and $\text{LiNi}_{0.33}\text{Mn}_{0.33}\text{Co}_{0.33}\text{O}_2$ cathode materials for Li-ion battery applications.
- Nano sized aluminium nitride powder using transferred arc thermal plasma reactor has been prepared.
- 100 KL of hafnium containing zirconium scrub raffinate processed for the recovery of hafnium oxide for strategic applications.
- 75 Kg hafnium oxide, 80 Kg hafnium chloride, 40 Kg reduced mass prepared and supplied to VSSC.
- 20 Kg of hafnium sponge supplied to VSSC.
- Resistor paste for hybrid microelectronic circuits.
- Solder paste for hybrid circuits and surface mount technology.
- PTFE/woven cloth microwave substrates for patch antenna applications.
- Ring type actuators for MEMS based microvalves and cystobalite for re-entry launch vehicle.

- Silicon oxycarbide coating on carbon foams for thermal protection applications.

b. Product developed for Dept. of Atomic Energy (DAE)

- Magnetic coil sensors fabricated and delivered to BARC.
- 7N purity zinc prepared and converted into less than 3 mm diameter shots for IGCAR.
- Medium and low dielectric ultra low loss microwave substrates.
- Multilayer actuators for robotics for BARC.
- Bimorph actuator based mirror for X-ray focusing for RR CAT, Indore.

c. Products/technologies developed to support Indian industry:

- Development of active material systems (electrodes) for Li-ion batteries.
- Low temperature co-fired ceramic (LTCC) based multilayer circuits and gas sensors.
- Nanostructured materials for hydrogen energy from sunlight by splitting H_2O and H_2S splitting.
- Silicon carbide (SiC) semi-insulating (SI) single crystals suitable for high temperature, high voltage applications.
- Recovery of precious metals like gold, silver, copper, palladium, etc., from electronic waste, i.e., printed circuit boards at pilot plant scale with capacity of 100 Kg batch at C-MET and 1000 Kg/ batch at industry.
- Ultra High pure (>7N purity) materials such as cadmium, tellurium, gallium, etc., for strategic applications.

- Thermal sensor based monitoring system for the early breast cancer detection.
- Sensors for radiosonde weather monitoring applications.
- Carbon aerogels and graphene based super capacitors for energy storage.
- Microwave substrates and resonators for wireless communication applications.
- Piezoelectric based multilayer actuators, flextensional actuators and bimorph for strategic are commercial applications.
- Kesterite (CZTS) based thin film solar cells.
- Magneto dielectric substrates for miniaturized substrates.
- Light weight X-ray absorption materials for medical fraternity.
- Photoconductor based light sensors and detectors.
- Nanomaterials for purification of petroleum products.
- Preparation of aerogel carbon @ 2 Kg/ batch by new cost-effective gel drying technique.
- Fabricated supercapacitors around 50 F/g using the indigenous aerogel super capacitor with resistance in the range of 30-35 mOhm.

9.3.3 Technologies ready for Transfer to Industry

- Digital thermometer for community applications.
- Graphene through chemical route for energy storage applications.
- Technology on (a) Environmental friendly treatment of PCBs and production of black copper enriched with precious metals (b)

Recovery of valuable and precious metal from spent printed circuit boards (c) Recovery of valuable and precious metals from black copper obtained from spent printed circuit boards.

- Microwave substrates with dielectric constant 3.5 for strategic and commercial applications.
- Transparent heater for fog removal applications.
- Wearable device and analysis system for early detection and screening of breast cancer.
- Aerogel based supercapacitors for energy storage applications.
- Lithium ion battery for energy storage applications.
- Modified silica fillers for space application.
- Piezoceramic compositions and components for commercial applications.
- Lead free X-ray absorbing materials & medical apron to protect from radiation.

9.3.4 Research Performance Indicator

- 68 research publications in peer-reviewed journals
- 29 presentations in conferences and symposia
- 80 invited talks
- 17 awards and honours
- 3 patent applications
- 2 technologies transferred

9.3.5 Major Pilot Plant and Infrastructure Facilities

- **Low Temperature Co-fired Ceramic (LTCC) based packaging facility**

C-MET, Pune has established a state-of-the-art Low Temperature Co-fired Ceramic (LTCC) facility for research and development in a wide range of applications. LTCC finds applications in microwave circuits, IC packaging, micro-sensor packaging, actuators and integrated microsystems.

Screen printing and dilatometer machines of LTCC facility

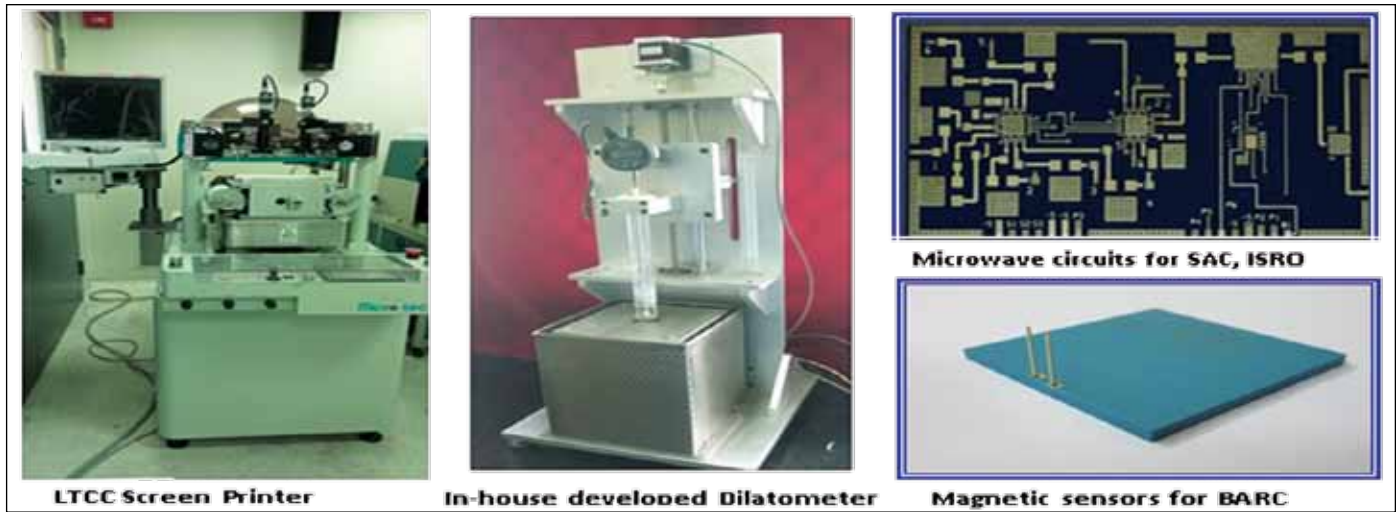

- Li-ion batteries: facility for synthesis of active materials, single cell fabrication and testing of prototype cells:** A full-fledged Li-ion battery fabrication and testing facility for coin/button (2032 type) and pouch/rectangular type cells has been set up at C-MET Pune. An indigenous process technology for development of anode and cathode materials also has been developed by C-MET Pune.



Shed and Front Fired Rotary Tilting Furnace (FFRTF) at e-waste facility



Lithium Ion Battery Research facility at C-MET, Pune

- E-waste plant: recycling demonstration facility:** A demonstration plant is established at CMET Hyderabad for the recovery of valuable metals such as copper, silver and gold from obsolete printed circuit boards (100 kg PCBs/day capacity) in environmentally friendly way. In order to promote environmentally recycling practices among informal sector, e-waste recycling facilities are extended to informal sector on chargeable basis.

- Hafnium sponge for strategic applications:** C-MET, has established first indigenous Hafnium (Hf) metal sponge plant at Hyderabad to meet ISRO requirement. The input material used is scrub raffinate from nuclear fuel complex containing 3-4 gpl of Hf %, which is further processed through solvent extraction to obtain HfO_2 . Chlorination, Kroll reduction and vacuum distillation have been employed to get 99% pure Hf sponge with respect zirconium. Hf sponge will also cater to the needs of Department of Atomic Energy (DAE) in control rods of nuclear reactors.
- Restriction of Hazardous Substances (RoHS) test facility:** C-MET, Hyderabad laboratory has established a state-of-the-art and NABL accredited chemical testing facility (bearing no. T-1780) for the analysis



of electrical, electronic equipment and related products to help the industries and developed a mechanism to identify and quantify the banned hazardous substances such as Pb, Cd, Hg, Cr⁶⁺, polybrominated compounds, under E-waste (management) rules 2016 in the area of polymers, metals. This is the only Government owned testing facility in India established with the financial support of Ministry of Electronics & IT (MeitY), Government of India.

9.3.6 C-MET's Future Area of Research

The following activities are planned to explore the cutting edge technologies in advanced electronic materials;

- High energy storage devices by researching on active materials for batteries for e-vehicle applications (supercapacitors, lithium ion battery).
- Development of 3-D printing inks and microwave devices for strategic and commercial applications.

EDXRF (ARL Quant'X)

AAS with hydride generator

ICP-OES (725 Agilent)

ICP-MS (X S Ion)



RoHS laboratory facility for the detection of hazardous materials

- Indigenous sensors for internet of things (IoT) and smart cities applications.
- Microwave substrates, terahertz and milli meter wave materials.
- Cost effective and environmental friendly recycling technologies and RoHS testing.
- Silicon carbide electronic device grade substrates for strategic applications.
- NTC materials for low temperature applications for airport weather monitoring system (-90 °C to +50°C).
- EMI-shielding materials, nanopowders of aluminum, iron, boron, Boron nitride, boron carbide, aluminium nitride for strategic applications.
- Graphene based electrical, optical and acoustic attenuators for medical, consumer and strategic applications.
- LTCC integrated PZT sensors for defense.
- Radio frequency identification (RFID) Tags on environment friendly, flexible substrate for smart applications.

9.4 ERNET India

9.4.1 MeitY-ERNET-NASSCOM Center of Excellence (CoE) for Internet of Things (IoT), Bengaluru

MeitY-ERNET-NASSCOM CoE for IoT was setup in June 2015 in Bengaluru with the overall objective of enabling India as technology hub for emerging technologies. In addition the CoE supports the Government initiatives in the social areas such as agriculture, healthcare, water, transportation, energy, security and privacy of data. The CoE is funded 50:50 on Public Private Partnership (PPP) model between MeitY and NASSCOM through its industry partners. Under COE-IoT Bengaluru, a number of start-ups have been incubated and are getting uninterrupted access to advanced

equipment. The start-ups have an opportunity to make direct connects with various strategic partners of NASSCOM and get validated by experts of the industry. The following are the highlights of CoE-IoT, Bengaluru:

- 54 Start-ups enrolled in house, connected with 500+ start-ups pan India
- 90 IoT researchers incubated
- 54 Prototypes showcased
- 22 Papers presented in global conferences
- IP's applied -56, Received- 9
- 11 Societal projects executed
- Employment Generated- 375
- Partners Signed up: Strategic-16, Co-create-2, Innovation-3, Infrastructure-5, Technology-4
- Event Organized / Participated: 26/27 Thought leadership events till date across pan India Focused on - Industry 4.0, Automotive/ Transportation, Healthcare, Energy, Agriculture, Smart Cities.

9.4.2 VSAT Services

ERNET India is providing satellite based VSAT links over C-band for Internet/ Intranet access to education and research institutes of Government, located throughout the country which mainly includes North-Eastern region, Andaman and Nicobar and Lakshadweep Islands. The VSAT links provided by ERNET India are highly reliable even during rough weather conditions and rains as they operate in C-band frequency spectrum which is least affected by rains, clouds, etc. Presently, the VSAT network of ERNET India is operating using the transponder space segment on GSAT-18 satellite of Department of Space. The network of ERNET India is equipped with state-of-the art VSAT technology and is capable of providing cost effective connectivity to small institutions as well as high capacity VSAT links to large institutes. The major achievements are as follows:

- **Established VSAT connectivity for Internet/ Intranet access in 60 locations of the North Eastern states of the country**

ERNET India has successfully established VSAT connectivity for Internet/Intranet access in 60 selected schools/institutes located in the remote parts of North Eastern states of the country. The project is funded by MeitY and its duration is 3½ years. The links were made operational from March 2017 and operation & maintenance of the links has to be done for 3 years to provide connectivity for internet/ Intranet access. Therefore, the project has been extended till 22nd February 2020. The aim of the project is to help narrow the gap between remote areas and other parts of the country. This will also help to promote equitable and sustainable development of remote areas of North Eastern states of the country through Internet.

- **Establishment of two High Capacity SCPC VSAT links for NKN Project**

ERNET India has established two high capacity SCPC VSAT links at Kavaratti, Lakshadweep and Port Blair, Andaman & Nicobar Islands for National Knowledge Network (NKN) project of MeitY. Presently, both the links are operating with 33 Mbps (Rx)/14 Mbps (Tx) data rates.

- **Establishment of 09 High Capacity SCPCVSAT links in the U. T. of Lakshadweep**

The establishment of 09 high capacity SCPCVSAT links in the U. T. Lakshadweep Islands for Lakshadweep Information Technology Services Society (LITSS) is in progress. The bandwidth configuration at 05 sites has been completed after its allocation by Department of Space on 31.10.2019 and remaining sites are in progress.

9.4.3 PoPs (Points of Presence)

ERNET India is serving academic and research institutions in the country by innovatively connecting them on Intranet and Internet using appropriate state-of-the-art technologies. Institutions anywhere in the country can now be connected to ERNET network. ERNET India provides services through its following 06 Points of Presence (PoPs) located across the country, which help in rapidly responding to the needs of the institutions in the country:

- ERNET India HQs, New Delhi
- Indian Institute of Technology (IIT), Guwahati
- University of Rajasthan, Jaipur
- National Informatics Centre, Salt Lake City, Kolkata
- VSAT Hub at Software Technology Parks of India (STPI), Bengaluru
- Indian Institute of Technology Madras, Chennai

All PoPs are equipped to provide access to Intranet & Internet through terrestrial leased circuits and radio links to the user institutions. These PoPs also provide technical support and hand-holding to user sites. The PoP at STPI Bengaluru provides Intranet and Internet access through Satellite.

In addition to 06 PoPs, ERNET India has setup regional centers at following 2 locations:-

- Bengaluru
- Chennai

9.4.4 R&D Activities

LiFi Experimental Test-bed Project

ERNET India is executing an internally funded LiFi pilot project jointly with IIT Madras. The objective is to study LiFi as an alternate communication technology and perform visible light communication experiments, and explore LiFi opportunities in

various deployment scenarios such as Hospitals, Smart building and smart cities. The indoor LiFi internet kit was setup at ERNET Chennai to study and demonstrate LiFi capabilities, evaluate the indoor performance and various experiments in single user scenario. As part of indoor experiment, measurement of coverage range, optical power received at different coordinates, outage analysis at different distance in both Line of sight (LOS) and Non Line of Sight (NLoS) were carried out. The experimental outcome of the test results were published in APAN44 Network Research Workshop and Global LiFi Congress 2018.

ERNET India had setup Indoor LiFi multi user testbed to study various performance issues like data rate, handover, interferences and also to carryout hybrid WiFi-LiFi aggregation experimentations and application use case deployments in a class room/ auditorium scenario.

Based on the outcomes of this experiment, ERNET intends to work on various proposals in the context of LiFi which includes Optical Wireless (OW) networks for rural and urban communications, a project approved by MeitY (dated 15.10.2019) and other proposals in pipeline which includes Quantum based secured Indigenous LiFi system and Centre of Excellence (CoE) for LiFi.

9.4.5 Internet of Things (IoT) Management Framework for Smart Cities

ERNET India is jointly working with Indian Institute of Science (IISc), Bengaluru to setup an experimental LoRaWAN network integrated with smart streetlights for real-time experimentation to study deployment, interference and management issues. Under this experiment, it has been considered to use simple streetlight as one of the application of Smart City that can be remotely monitored and controlled via intelligent applications. The experimental LoRaWAN network was deployed in IISc campus to study performance limits of LoRaWAN having an environment comprising of regions of moderate to dense foliage and interspersed buildings as can be typically found in cities, large campuses, parks and so forth.



Fig. LoRaWAN deployment satellite view



Fig. LiFiMulti user testbed with user node at ERNET Chennai

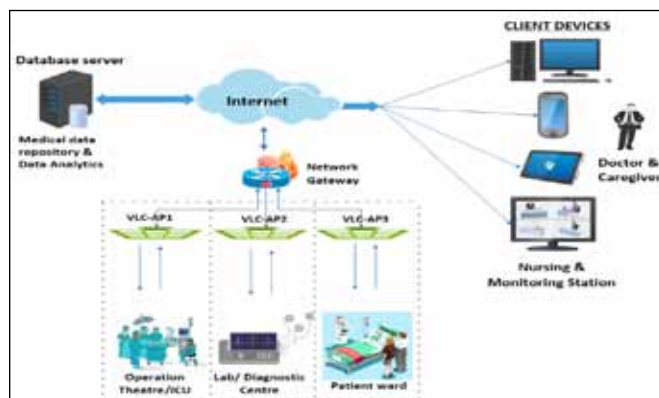

Fig. LiFideployment in Healthcare scenario (proposed)

LoRaWAN smart streetlights were developed and deployed in IISc campus and ELCITA Electronic City for real-time experimentation. Here, the LoRa gateway (pole gateway) is a low cost compute box that can connect to cameras, temperature, humidity, air quality and other sensors. This pole gateway can perform the local analytics and push data to server/ IoT middleware through LoRa communication or passive optical fiber. Some of the smart city applications using this platform could be traffic control using cameras, pedestrian density based lighting, or event based brightening of street light and more. The experiments carried out to understand LoRaWAN performance and scalability aspects in real time are being published as a book chapter in Elsevier book titled LPWAN Technologies for IoT and M2M Applications. ERNET is also participating in Smart City Consortium with IISc to develop standards interface and Indian Urban Data Exchange (IUDX).

9.4.6 Smart Building PLC Testbed

ERNET & IIT Madras is jointly setting up Smart building Power Line Communication (PLC) testbed towards Energy Efficient Buildings. Under this project, indoor parameters like air quality, temperature, ambient light, occupancy including power consumption are measured over PLC. Currently, APIs are being developed for data collection and analysis. The outcomes of this

project will create opportunities to deliver large scale deployments/proposals for PLC based sensing applications in smart buildings.

This project is sponsored under the IEEE PLC testbed initiative by ST Microelectronics & SLSCorp



Fig. PLC Testbed at ERNET Chennai

9.4.7 Cyber Performance and Tech-Culture Fusion Programmes under APAN Asi@ Connect Initiative

ERNET India as part of the project collaboration under APAN Asi@Connect initiative has been participating in the tech-culture fusion platform including training programmes and Cyber Performances in an 18 months project starting from July 2017 with 6 beneficiary countries, namely India, Vietnam, Malaysia, Bangladesh, South Korea and Pakistan. The objective is to build a long-term exchange platform for tech-culture fusion that connects applications, data, people and processes and also to understand tech-culture fusion platform issues using the TEIN network.

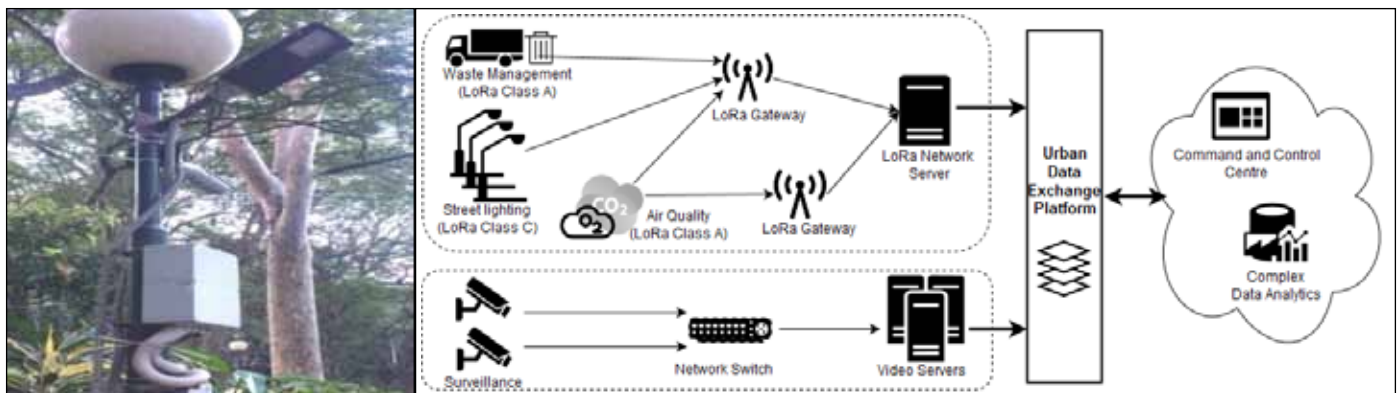

Fig. Smart City Testbed and LoRa enabled Smart Street Light

The 2nd Live Cyber performance event under this project was held in February 2019, where artists/musicians from India, Vietnam, Pakistan, Malaysia, Korea and Bangladesh have performed together over the TEIN and National Research Education Network (NREN) of each country exchanging high quality video/audio. ERNET India, Chennai has organized this event and student artists from Anna University have performed during the event.

9.4.8 Domain Registration

ERNET India is an exclusive domain registrar for education and research domains; registering the domains under **ac.in**, **edu.in** & **res.in** from 2005. The domain registration, renewal & modification process has been fully automated with online payment facility for registering and renewing domain names on just a click. The automated website is GIGW compliant and runs on dual stack IPv4 and IPv6. In automated systems, customer can modify their DNS entries and other permissible information related to their institution online, avoiding security breaches. ERNET also registers domain names under विद्या.भारत under Internationalized domain names (IDN).

9.4.9 Setting up of eClassroom Infrastructure in 50 Medical Colleges for MoHFW

ERNET India is the System Integrator (SI) of project titled “Setting up of e-classroom Infrastructure in 50 Medical colleges” under NMCN Scheme of Ministry of Health and Family Welfare (MoHFW). ERNET India has completed Supply, Installation, Testing and Commissioning (SITC), Training for the requisite equipments for e-Classroom. The implementation by ERNET India has facilitated tele-education, tele-CME, sharing of surgical & interventional Skill, capacity building of HRH etc. for medical and paramedical professionals. The Operation & Maintenance activity of the project will continue for 5 Yrs. (i.e. till 2023)

9.4.10 Development/renovation of Government/State Government websites accessible for Persons with Disabilities (PwD) as per GIGW /WCAG. 2.0 (A, AA level) Standards

Under Accessible India Campaign, one of the target is to make all Govt./State Govt websites accessible to all. For this Department of Empowerment of



Fig.2nd Live Cyber performance - Artist from Korea, India, Bangladesh, Pakistan and Malaysia

Persons with Disabilities (DEPwD) has funded ERNET India to make State Govt. websites accessible to the Divyangjan. ERNET has been given 917 websites of 16 states and 7 UTs of the country to make them accessible and responsive. Accessibility of all websites will be achieved by making them responsive, CMS based and compliant as per Guidelines for Indian Govt. Websites (GIGW) & Web Content Accessibility Guideline(WCAG 2.0 A,AA level)

9.5 Government's IT infrastructure: National Informatics Centre (NIC)

9.5.1 About NIC

Established in the year 1976, National Informatics Centre has emerged as a promoter of digital opportunities for sustainable development. NIC has rich experience in providing ICT & eGovernance support in last 4 decades. To its credit, NIC has spearheaded "Informatics-Led-Development" by implementing ICT applications in social & public administration and facilitated electronic delivery of services to the Government (G2G), Business (G2B), Citizen (G2C) and Government Employee (G2E). By establishing the ICT Network, "NICNET", NIC has facilitated the institutional linkages with all the Ministries /Departments of the Central Government, 36 State Governments/Union Territories, and about 720+ District administrations of India. NIC's has been instrumental in spearheading e-Government/e-Governance applications in government ministries/ departments at the Centre, States, Districts and Blocks, facilitating improvement in government services, wider transparency, promoting decentralized planning and management, resulting in better efficiency and accountability to the people of India.

NIC has aligned itself with mission and vision of Digital India Programme. Generic, configurable eGovernance products/applications have been

developed using cutting edge technologies including mobile, cloud, data analytics, BI and advanced GIS. Various centres of excellence have been created to strengthen the nationwide digital infrastructure and services playing catalytic role in the country's road to digital transformation in the next decade. NIC products and Services have also been recognized internationally with many countries showing keen interest in taking NIC's support in IT & eGovernance. The data centres of NIC host more than 8000+ websites of the Government in the secured environment. The NIC National Cloud (Meghraj) is presently hosting a number of critical applications on over 18,050 virtual servers and 1110 User departments under Digital India. NIC's eGovernance Product and Services were showcased in meetings held with high level delegations of Kazakhstan, Morocco, China, Kyrgyzstan, Uzbekistan, Denmark, Indonesia, Bangladesh, Venezuela, Zimbabwe, Japan, Czech Republic and Latvia for a future bilateral cooperation.

NIC State Centres along with their respective District Centers are continually engaged to automate and accelerate eGovernance processes in close interaction with Government Departments and have successful in harbingering the benefits of digital revolution to the distant parts of the country.

9.5.2 Network Services

9.5.2.1 NICNET

Core of NICNET backbone is fully upgraded to multiple 10 Gbps capacity with sufficient redundancy. States are connected through multiple 1/10 Gbps links and districts 34/100 Mbps links with redundancy built at State and District links. Last mile redundancy for NICNET has been extended to more number of districts, with primary link from BSNL and secondary links from Railtel/PGCIL. Most of the Bhawan links at Delhi which were on 34

Mbps are upgraded to 100 Mbps and those on 100 Mbps are upgraded to 1Gbps.

Direct peering of NICNET with BSNL, PGCIL and Railtel are completed at Delhi and Hyderabad for saving Internet Bandwidth and faster access of each other's Network and Data Centre. Peering with Google, Microsoft and Akamai Content Delivery Network has facilitated faster access to Google services and other important International web sites. Re-structuring of Videoconferencing network has enabled to minimize delay and handle large scale important video conferencing such as PRAGATI of Hon'ble PM, GST Council Meetings by Hon'ble FM etc.

High speed Internet services are provided to national data centres to ensure that the applications hosted are accessible to users across the globe with minimum latency. Capacity planning and upgradation of Internet Gateway at regular intervals has been undertaken to provide smooth Internet access to all NICNET users throughout the country. To maintain accurate timing and synchronization of all network elements and servers on the network, Stratum-1 clocks are installed at Delhi and Hyderabad.

NIC VSAT Network NICNET has been offering satellite based VSAT Network services over Ku-band VSATs for providing Data and Video application.

NIC is also providing satellite bandwidth from NICNET pool for delivering e-governance services to VSATs of various projects of central/state government departments such as Rural, Taxation, Treasury, Finance, Health and Food supplies in geographically difficult locations where terrestrial connectivity is either not available or reliable. For running the VSAT services, NIC has leased transponder bandwidth from DoS/ISRO on the GSAT-18 satellite.

9.5.2.2 NKN

NKN empowers Digital India, as it is the primary backbone for all e-Governance initiatives in the country. It is the only network globally, that carries R&E, Internet and e-Governance traffic as independent verticals under one umbrella. NKN has multiple 10G links that are combining a core bandwidth of close to 1000G, providing secured and highly resilient connectivity across major Institutions for research, education and e-Governance.

NKN has a strong backbone connectivity with 31 Points of Presence (PoPs) in various State Capitals and 92 core links connected with meshed topology. Moreover, currently over 700 Gigabits (reaching a peak of 5 Petabytes) of data is flowing within the NKN backbone every day. Over 40 links (premium Institutes, SDC (State Data Centres) & SWAN of many states) have been upgraded to 10 Gbps. NKN has also established a High Capacity SCPC VSAT Connectivity at Kavarati, Lakshadweep and Port Blair, Andaman & Nicobar Island.

9.5.3 Data Centre & Cloud Services

9.5.3.1 Data Centre

NIC provides Data Centers Services from National Data Centres at Delhi, Hyderabad, Pune and Bhubaneswar. National Data Centre (NDC) at Bhubaneswar is a Cloud-enabled data centre which has been offering cloud services to Govt. Departments since its inauguration during 2018. The cloud services are being offered on various cloud platforms backed by state-of-the-art infrastructure to support the DC operations. NDC Bhubaneswar is also offering co-location services by Govt. Organizations.

National Data Centre at Delhi was upgraded with high speed Network backbone, 1.6 Petabyte Enterprise class storage,



high throughput Network Load Balancers, and Intrusion Prevention Systems. Solution for Backup as a Service & Storage as a Service has been implemented. ICT infrastructure of number of national level projects was hosted/enhanced; these include E-office, e-Courts and e-Transport. Data centres at Pune & Hyderabad are also upgraded with high speed network backbone and storage capacity enhanced. National Data Centre at Hyderabad is being renovated with a capacity of 106 Racks.

9.5.3.2 National Cloud

NIC launched National Cloud Services in year 2014 under MeghRaj Government of India Cloud Initiative. NIC Cloud Services are being provided from multiple locations of National Data Centre. Various new services are now offered on Cloud including Application Programme Monitoring (APM) Service, Data Analytics (DA) Service, Resource Monitoring (RM) Service and Container Service. In order to cater to the projects envisioned under Digital India Programme and growing requirements of existing Projects, over 18,000 Virtual Servers were provisioned and allocated to over 1100 Ministries/Departments for e-Governance Projects. During this year Mini Cloud setups have been made operational in ten state units of Assam, Bihar, Chandigarh, Chhattisgarh, Haryana, Karnataka, Kerala, Punjab, Rajasthan and Tripura.

9.5.3.3 Command and Control Centre

NIC has been offering services to the government through its 4 National Data Centres and 30 Mini Data Centres across the country. CCC has been set up keeping in view the requirement of a centralized facility to seamlessly monitor the availability of all these Centres and Cloud Services. Over 10,000 e-Governance applications are being hosted by these Centre's. CCC is providing users with a customized dashboard of Network Management System (NMS) to enable them to monitor their respective applications. NIC is also

providing Application Performance Management (APM) through CCC to improve the availability, performance and functioning of critical applications.



Shri Ravi Shankar Prasad, Hon'ble Minister, during the presentation session

9.5.3.4 NIC-CERT

NIC-CERT has been setup with the objective of creating a comprehensive security and incident response framework that integrates world class security components and inbuilt threat intelligence for detection, prevention and incident management. Using the tools, the team monitors and correlates events that would help in generating a canvas of the attack surfaced and identify the vulnerabilities and possible exploits. The mission of NIC-CERT is to collectively lead and coordinate the cyber security incident response and strengthen the cyber security posture of National Informatics Centre. The core mission activities of NIC-CERT include:

- To co-ordinate and respond to Cyber Security incidents happening in NIC
- To provide Intelligence or advisory on the prevailing Cyber Threats and vulnerabilities, for proactively securing NIC's network and assets.
- To Establish and Maintain a centralized Log Management system for NIC and maintain a Knowledge base of Cyber Security Incidents handled by NIC-CERT.

Some of the key milestones achieved by NIC-CERT are:

- Published around 200 Security Advisories and 220 Threat Intelligence Alerts.

- Played a crucial role in securing Government IT Infrastructure by proactively identifying over 2500 vulnerabilities affecting Government ICT Infrastructure.
- Identified many security compromises, Govt. credential compromise, investigated hacking/defacement incidents, phishing incidents, typo-squatting domains, fake Government websites etc.
- Undertook initiative to secure the Government LAN/WAN, by proactively identifying potential compromises and malicious traffic in the network.
- Sent regular Security Overview reports to the Chief Information Security Officers (CISOs) of various Ministries and Departments.

9.5.4 Cyber Security

Cyber security incorporates the security standards and procedures followed to ensure protection of sensitive data, personal information, intellectual property etc. Multi layered access mechanisms are implemented on information systems for prevention from security breach and unauthorized access.

9.5.4.1 Network Security

The Network Security Division is in relentless pursuit of achieving CIA (Confidentiality, Integrity, and Availability) of ICT assets in NICNET through deployment of expert manpower, appropriate tools, and state-of-the-art technologies.

The Network Security Division (NSD) of NIC is engaged in assessment, planning, deployment and management of security devices and solutions across the NICNET in general and the Data Centres in particular. The security span of NSD comprises of all National and State Data Centres, over 1000 LANs of Govt. offices and MPLS networks, more

than 2 Lakh endpoints and a series of networking devices deployed across the country. A dedicated team actively monitors real time attacks on 24x7 basis.

The Network Security Division (NSD) conducts Security Audit of Data Centres and Bhawan Networks on regular basis and on demand. Besides, review of the network audit performed by third party vendors in NICNET was also undertaken. Cyber Security Policies, Guidelines, Advisories and Standard Operating Procedure(s) are also being regularly prepared, updated and circulated to the NICNET users. Network Security Division is involved in vulnerability assessment of ICT assets in Physical, Virtual, and Cloud environments at regular intervals and on demand. The Network Security Division manages the 24x7 Security Monitoring Centre to ensure real time monitoring, detection, prevention, analysis and reporting of Cyber threats and attacks.

9.5.4.2 Application Security

NIC is formulating and updating the Security Policies for NICNET as and when required. Security Audit of Web Applications / Websites, Penetration Testing and Vulnerability Analysis, SSL compliance testing, Version Detection for application hosting environment with infrastructure compliance checks are also done as per user requirement. Critical Web applications are secured through Web Application Firewall (WAF) to counter Application layer threat, Management and administration of deployed WAF solutions configuration of critical sites including CMF (Drupal) based portals, WAF service support at NIU Hyderabad for non-compliant web applications and 24x7 monitoring service. The center provides Incident Handling and Malware Analysis, Sanitization of security controls based on analysis results and Issuing advisories to NICNET users.

9.5.5 Web and Messaging Services

9.5.5.1 Domain Name Registration

GOV.IN domain registry service registers domain name for all government offices across India. Services of GOV.IN domain registry are being provided by the website <https://registry.gov.in>. NIC is an exclusive registrar for Gov.in since 1st Jan, 2005. Till date 6,725 3rd level domains are registered, and more than 1,49,322 sub domains are registered on registry.gov.in.

9.5.5.2 Email

eMail forms the backbone for all eGovernance initiatives in the Government. As part of the mandate under the Digital India program, Government of India is providing a secure eMail service to its officials for secure communication. NIC as the implementation agency, is providing secured email service along with 24/7 support to the Government, both at the Centre and State. All services under e-mail are offered free of cost to all officials under Ministries, Departments, Statutory Bodies, Autonomous Bodies, States and UTs.

The service, with the primary domain of @gov.in, is one of the largest eMail services in India. The service supports more than 1,050 virtual domains with over 2.6 million accounts, the growth in terms of complexity has been evident. The daily email traffic is more than 2 crore eMails per day.

The eMail service is based on five Primary Pillars: Security, Performance, Redundancy, Service Continuity and Rich feature Set. The service provides plethora of features to the users, some of the prominent features are: Supports 11 Languages, (currently with Hindi and English), supports Internationalized domain name (IDN)-with user ID as, assigning multiple templates per user as per roles of the officer and Kavach providing Geo Fencing and Device Mapping, NIC also provides eMail distribution list for bulk email for official purpose.

9.5.5.3 SMS

SMS gateway service is also provided by NIC as a part of its messaging solution. The service is available to all Government applications both at the centre and State. It has various advance features like PUSH, PULL, block out time, scheduling, localization of content, international SMS, OBD (Outbound dialling), Missed call service, SMS analytics/visualisation etc. Currently around 2000 eGov applications are integrated with the gateway which includes various critical projects like Mann Ki Baat, MyGov, Sampark, Digital India portal, eHealth, National Scholarship portal, Jeevan Pramaan, BAS, Mother and Child Tracking, Khoya Paya, Income Tax, Vahan, Sarathi, eProcurement, e-way bill, GST etc. The average monthly traffic is about 90 crore SMS. The service also offers multilingual SMS options for localization in different parts of our country. In the year 2019, 300 new SMS accounts were created. The number of SMS campaign executed for various ministries and department is 114. MoU has been signed with Punjab and Haryana for SMS services. TRAI has come with new TCCCPR 2018 [Telecom Commercial Communication Customer Preferences Regulation]. The same has been complied by NIC SMS platform.

9.5.5.4 VPN

Virtual Private Network is a secure and cost-effective method of connecting private networks and mobile users over Internet. NIC's VPN Service is used by Government officials, Central and State Government departments, PSUs and Autonomous bodies under Central and State Government who are authorized for administration, to update their web sites and remote management of the servers hosted in NIC's Data Centers. This includes cloud users for administration and management of VM Servers / cloud dashboard. NIC is also promoting new remote access technologies like WebVPN. This in addition to being lightweight and scalable,

(requires only a Web Browser) is also secure (through two factor authentication) and is a solution customized in-house by an Indian company. NICNET has been extended through site-to-site VPN with Indian missions abroad e.g. Dacca. Of late, NIC's VPN division is in the process of carrying out Data Analytics based on VPN logs.

9.5.5.5 GIMS

GIMS is an Open source, Secure, Cloud enabled and Indigenous platform developed by NIC for instant messaging within Government. It comprises of a mobile app and a portal. The App is for Inter and Intra Govt. communication at various levels and can be configured to manage messaging & integration with other Government apps. The management portal is for Organization and employee on boarding, official group management, dashboard and analytics. GIMS is hosted at NDC Sastry Park and the Android and iOS version are available at <https://gims.nic.in>.

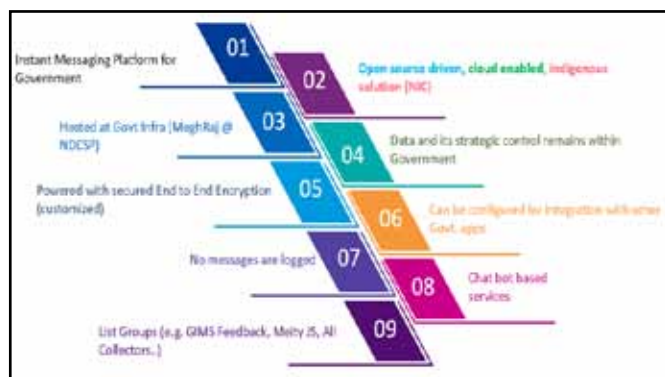

Highlights of GIMS include One to One and Group Messaging, Single sign-on with LDAP, end to end encryption, API based integration with eGov applications like Nice mail, Digi locker. GIMS is the official communication channel for Alerts and notifications from e-office, Application Security, NIC CERT, NIC HRMS, Duty Portal etc. It has Encrypted Backup facility and Chatbot enabled instant Dashboard services along with Instant Feedback System.

9.5.6 Video Conferencing & Webcast

9.5.6.1 Video Conferencing

Videoconferencing facilitates direct interaction with concerned stake holders and saves time & money. Videoconferencing services are being used for monitoring of various Government Projects, Schemes, Public Grievances, monitoring of law and order, Hearings of RTI cases, Tele-education, Tele-medicine and Launching of new schemes etc. NIC's VC services are being extensively used by Hon'ble Prime Minister, Union Ministers, Governors, Chief Ministers of states, Cabinet Secretary and Chief Secretaries, Chief Information Commissioner and various other senior officials across country. NIC is also providing web-based desktop videoconferencing services to users of various departments of central government & state governments.



9.5.6.2 Webcast

NIC has been providing live/on-demand webcast services to Central and State Government for important National, International and regional, educational events and conferences. Live webcast services are provided for government TV channels such as Lok Sabha TV, Rajya Sabha TV, Doordarshan News, DD-Kisan, UGC – CEC higher educational channel, DD Punjabi on 24x7 basis.

Important events such as Union Budget speech, President's address to the nation, Prime Minister's

Mann Ki Baat & other speeches, Independence and Republic Day celebrations at New Delhi, Air Force Day, Dance and cultural Festivals, PIB press conferences, NIC Knowledge sharing, NKN events, proceedings of state assemblies, other national and international events/conferences like Make in India, Skill India, Start-up India, Digital India, International Yoga Day were covered.



9.5.7 GIS & Utility Mapping

9.5.7.1 GIS

In order to fulfil the objectives of Digital India and to establish end to end geo-spatial electronics delivery systems as part of National GIS Mission Mode Project, GIS Platform established by NIC, MeitY, using NICMAPS Services has been revamped as "BHARATMAPS". This depicts core foundation data as "NICMAPS", an integrated multi-scale, multi-resolution base map service using reference data from Survey of India, ISRO, FSI, and RGI and so on. This encompass large number of layers containing administrative boundaries, transport layers such as roads & railways, forest layer, settlement locations etc., including many base map services.

Map Services are being provided to various ministries and departments like Ministry of Sanitation and Drinking Water for SBM (Gramin), Drinking water Portal etc. Similar Services are being provided to Department of Land resources, Department of Labour, Vahan/ Sarathi Project, CGHS, HMIS etc.

Other achievements include GIS For Financial Inclusion (DBT GIS Ver 1.0) application maps all

Banking and postal assets and is available in G2G domain. A Mobile application Jan dhan Darshak and citizen application <http://findmybank.gov.in/> are made available during the year. GIS for Panchayati Raj: Gram Manchitra, an application for preparation of Gram Panchayat Development Plan (GPDP) <https://grammanchitra.gov.in/> was launched and dedicated to nation by Shri Narendra Singh Tomar, the Hon'ble Minister for Rural Development, Agriculture & Farmers' Welfare and Panchayati Raj, Govt. of India during the National Panchayat Award Ceremony on 23rd October, 2019. Mapping of all Roads managed by Mandi Board & PWD as value addition at top of Road layers generated by NIC. NIC has been awarded Certificate of Appreciation for enabling DOT in achieving Bharatnet Phase 1 target of One lakh Gram Panchayats.

9.5.7.2 Utility Mapping

Utility Mapping Division plays a crucial role in the management and planning of utility service systems. It lends order and meaning to the chaos by generating detailed and precise digital maps of these systems. Utility Mapping Services mainly includes; Global Positioning System, Topographic/ Cadastral Mapping, Photogrammetry and AM/FM/ GIS.

Some of the major projects in Utility Mapping Division accomplished in this financial year are Yamuna Expressway Industrial Development Authority (YEIDA) and Slum Rehabilitation Authority (SRA) Geo portals, Mega City Portal, Delhi Jal Board, E-Dharti web Portal <http://umd.nic.in/edharti>, Assistance to Goa State Urban Development Agency (GSUDA) for creation of geo referenced land record portal, smart solution for Storm water Management (SSSM) for Delhi Jal Board with the available Water and Sewage Network on top of Delhi Basemap in which faults can be uploaded on real-time basis.

9.5.8 Support Services

9.5.8.1 Digital NIC

DigitalNIC has been started with a vision to provide a single window solution to NIC employees for all kind of Administrative, Technical & Finance activities. It provides dashboard for both individual & functional levels like DG, HoG, SIO, HoD and Individual Employees. Various employee centric services are provided to individuals, employees can view their Profile, Service Book, Entitlements, Tours, Leave Balance, Payments, Payslip, Form 16, GPF Statement, IT Statement, Digital and Physical Assets, Appraisal, Attendance, Immovable Property Return, Projects, Team, Directory Search etc. Some online services are also provided to employees such as Online APAR, WCAR, PAC, eTour, NOC, News Paper, Tuition Fee, Online Exam (GudApps), and Monthly Performance Report, Feedback etc.

Seniors officers can view the details with respect to their State or Group, they can view the technical and administrative manpower distribution within their state or group, total number of districts or division and employees working in those districts or divisions, they can monitor the attendance of their team, employees on tour or leave, status of appraisal reports and applications pending for approval and other reports.

9.5.8.2 Service Desk

NIC service Desk is a Single-window Platform for resolving various service-related issues / requests. It is a Single point of contact for users for all NIC services with fastest possible routing of issues to the concerned. It ensures transparency and accountability. There is timely resolution of services with provision for escalations. Detailed responses are given to users' issues with feedback. 25,17,013+ serviced tickets have been handled with an average of 4,500+ new tickets per day, involving 45 plus core services and 1,000 plus govt. offices covering all states/UTs and districts.



9.5.8.3 IVRS

IVRS is used as the cheapest mode to collect/ disseminate data across the world. It provides a 24x7 support-contact mode for people on the move and for those with just the basic phone facility. It is seen as a major mode to disseminate information in the e-Gov era, to touch base with the grass roots level through the basic phone.

Hon'ble PM's Mann Ki Baat (MKB) Data collection on 120 lines for approx. 10 days a month. IVFRT e-TVoA 24x7 Help Desk, application status and general information clocking the maximum no of calls by people from abroad seeking eVISA support. Kailash Mansarovar Yatra (KMY) Helpline with 8x5 help desk, application status, draw and waiting list status and general information from February to September (during yatra period). Additional work done for updating the Live Yatra progress and disseminate the information on the existing IVRS. National Dental and Oral Health Awareness (NDOHA) - Hindi Version helpline started. CBSE 10th & 12th Results dissemination over IVRS. A POC Voicebot with speech recognition was also created to cater to the NIC Service Desk. Some of the other applications are Fertilizer Management Registration (eFMS), case status for Hon. Uttarakhand High Court, Case status of National Commission for Consumer case redressal (CONFONET) and Voter ID application status for CEO Delhi. Total call count registered was **8,83,916**.

9.5.8.4 Chat Bot for NIC Service Desk

Social Inclusion using AI is one of the objectives that NIC has been working for. Towards that end it has worked with Ministries and Government Departments to provide conversational bots to facilitate Citizen interactions with Government in both English and Hindi in text and speech. To provide these bot services, NIC has come up with a generic framework called VANI (Virtual Assistant of NIC). Chatbot for RTO licenses has been released in October and is getting around 3 lakh hits/day. Chatbot for eVigilance Chandigarh is in production. More bots are in pipeline for Lok Sabha Secretariat, Niti Aayog, PDS Puducherry, CONFONET (Consumer Case Status), iKhedut (Bot in Gujarati & English for farmers), eWay Bill etc.

9.5.9 Capacity Building

9.5.9.1 e-Learning Mode

NIC is leveraging the e-Learning systems, viz. VidyaKosh, Webcon and Webinar to impart training to its officers at all levels.

a) VidyaKosh – A Learning Management System (LMS):

Vidyakosh is a National Digital Repository to store, index, preserve, distribute and share the digital learning resources with NIC employees. It facilitates efficient administration of self-learning for all NIC officials. More than 300 courses have already been made available in Vidyakosh.

b) Webcon – A NIC Virtual Class Room.

Virtual Classroom Setup- 'Webcon' is well established and being used regularly by different divisions of NIC for product, technology training and project implementation. These sessions are being attended by NIC officers from all over NIC offices in states and districts across the country. Total no. of 472 virtual class room sessions (with the participation of 8892 officials) were held during 2019-20.

c) Webinar:

NIC has also created a Webinar platform aimed for sharing knowledge among the peer group, updating individuals on the Emerging Technologies, sharing experiences & challenges faced, and improving communication skills. More than 700 webinar sessions have completed since its inception in past two years. This year around 298 Webinars have been conducted. The e-learning services have resulted in significant time and cost saving of the government workforce by reducing travel for training and meeting.

9.5.9.2 Classroom based Training Programs

Training Division has been instrumental and a driving force in organizing various Needs and Assessment based Training Programmes for all NIC Officers at NIC and Other Institutions as well. Various Training Programmes have been conducted in NIC itself making best use of existing Infrastructure VC Facility, International Class room, webcast, and have also tied up with other premium organizations such as IIMs, IITs, ISTM, NIFM etc to utilize their Infrastructure and faculty to make the participation in training programmes feasible for all the officers across country.

Training Division, NIC has conducted training programmes and workshops on Emerging Technologies namely, Artificial Intelligence and Deep Learning, ELK Stack for Data Analytics, Internet of Things etc, Geographic Information System (GIS), Development of Mobile Apps on Android and iOS Platforms, Network Technologies and its components, Enterprise Architecture, Cyber Security, Cloud and Data Centre, API Management, Agile Development & DevOPs, Software Quality etc. During 2019-20, Fifty (50) workshops/Trainings (approx) have been conducted (for NIC Officials) at NIC-HQ and at premier institutes such as ISTM, IIT – Delhi, CoD, Hyderabad etc.

9.5.9.3 Executive Briefings

NIC initiated Executive Briefings (EB), a series of Short duration sessions of two-hour duration on varied Topics for senior officers of NIC. Topics on Emerging Technologies are addressed by the Invitees/Speakers from the Industry, NIC, Institutes, Government Organizations etc. So far, 15 Executive Briefings session have been conducted on Block Chain Technology, Physical and Digital Records, Social Media: IT Act and Digital Marketing, Software Intelligence, Micro Film Technology, Artificial Intelligence, Micro Services etc.

9.5.9.4 Induction Training for New Recruits

NIC had recruited Scientist B at NIC Hqrs and NIC States. Extensive 15 days Induction Training to new recruits of 60 sessions was given on NIC Functioning, NIC Services (Data Centre and Cloud Services, eMail, Application security, Network Operations, Network Security, VC, Webcast etc), Emerging Technologies (AI, Block Chain, Open API, Micro Services, Chatbot, Internet of Things (IoT), Enterprise Architecture, Block Chain and its Application, Social Media), NIC eGov Products (Digital NIC, eOffice, LGD, Service PLUS, eTransport, eCourt, ePrison, DARPAN, eTAAL, MNREGA, Digital Payment etc), Technology (Windows Server, RedHat/Linux Server, IVRS, VoiceXML, RDBMs (Postgres, SQL Server), Open Source Application Server, OSS Web Server, PWA, GIS & RS, PHP, Python Overview, UX of Web and Web Applications, CMS (Drupal, WordPress), OSS Policy, OSS Stack/Tools, OSS Security Advisories, Software Quality Assurance of Egov Applications, Performance Testing, mobile application development), Administrative and Personnel Rules and Regulations, Communication Skills and Personality Development.

9.5.9.5 Digital India Internship (DII) Scheme for NIC

DII was launched on 10th April 2019 and 25th October

2019 for Summer and Winter Sessions respectively for inviting Applications from Students for doing two months internship at NIC Hqrs and NIC States. Broad functional areas for which applications were invited were such as: Cloud Computing, Artificial Intelligence, Cloud Orchestration, Micro Services, Open APIs, Enterprise Architecture, Data Analytics, DevOps Tools, Software Quality Assurance, Internet of Things, Cyber Security and UI/UX.

9.5.9.6 GuDApps Test

NIC has raised the standard of streamlining software processes for development of robust, interoperable, intelligent and user-friendly e-governance applications with consistent interfaces through the guidelines for Development of Good Applications (GuDApps). The GuDApps test is completely online paperless process and all NIC officers up to the level of Scientist-E have to clear it. The GuDApps online test is developed in an open source technology platform and consists of questions from chapters of Guidelines for Development of e-Governance Applications (GuDApps) i.e. Data Quality & Document Upload, Authentication, Forms, Reports and Application Framework.

The GuDApps test has been successfully cleared by 2426 NIC S&T officers. Similar test on Application Security were also conducted and 297 NIC S&T Officers have cleared this test. In addition to this, GuDApp tests for outsourced resources deployed through NICSi/NIC/GEM projects have also been conducted and more than 825 outsourced resources have cleared this test till date.

9.5.10 E Governance Product and Services

9.5.10.1 S3WaaS

S3WaaS (Secure, Scalable & Sugamya Website as a Service) is a website generating framework developed by National Informatics Centre (NIC), to improve Indian Government Presence in

Cyberspace by enhancing the quality of web space with respect to Design, Technology and Content. S3WaaS is built with an objective to empower the government entities to generate accessible websites for publishing information in a multilingual way without much technical knowhow in a short span of time.



9.5.10.2 E- Granthalaya

NIC has developed an application namely E-GRANTHALAYA - A Digital Agenda for Automation and Networking of Government Libraries. The application is an Integrated Library Management Software, useful for library computerization. The current version of the software is Version 4.0 – which is Cloud Ready Application, hosted in NIC cloud and provides web-based solution for libraries. This helps to convert traditional libraries to e-Libraries.

The software has been implemented in 500 libraries during current year, and thus, total 5000 libraries have been automated using this application, providing e-Library services. Out of these, 1600 libraries are on NIC Cloud which have made available 86 lakhs book catalog records with 6000 e-Books made available for reading and downloading to their members.

9.5.10.3 Mobile Apps Store

Mobile Application Division has Nodal center in NIC-HQ Delhi and four competency centers at Chennai, Shimla, Patna and Kannur. All the centers are collectively working for development and hosting of mobile apps in android and iOS. In order to bring all these apps under one umbrella for better visibility

and global reach from single point of contact NIC, has subscribed to user accounts in Google play store and iOS iTune. Now all the Mobile apps developed in NIC are uploaded on play store under NIC account only. Till date NIC has published 70 eGovernance Mobile Apps on Google Play. Total mobile app count reached to 300 published mobile apps on iOS AppStore. Total count on iOS Account reached to 30.

NIC Mobile App Store (<https://egovmobileapps.nic.in>) is a repository of Mobile Apps in e-Governance domain developed by NIC. Apps store portal aims to collect metadata of mobile apps for analysis. Portal is a single source of truth for mobile apps in NIC and showcases mobile app development capability in NIC. Mobile App Store portal promotes reusability of Mobile Apps and helps in knowledge sharing among different divisions, NIC cells in ministries and competency centers in NIC. Mobile App Store facilitates searching on mobile app on keywords, Different reports and graphical representation of mobile apps data is shown. Total mobile apps on NIC Mobile App Store have reached to 400.

9.5.10.4 NEVA (National e-Vidhan)

e-Vidhan Application 3.0 is a Generic Product suitable for a worldwide implementation enabled with provisions for inclusion of workflows and business rules for any Legislature and Municipal Corporation. It is a complete role-based workflow ICT solution facilitating paperless working of the House, House Committees and e-Constituency Management. It has been designed and developed by the NIC Himachal Pradesh based on the experience & knowledge gained over the last 6 years in this area.



9.5.10.5 E- HRMS

eHRMS provides e-Service-Book along with services affecting service book. The product facilitates auto updation of service book through various services from apply to approval through efficient and customizable workflow. The product is build using Open Technology Stack. The product uses layered approach for Services, Business Rules and Workflows. Business Rules and Workflow are customizable. The project aims for real time updation of e-servicebook and uniform implementation of the service record rules across the government. The project also provides Management Dashboard. Dashboard provides various analytical reports to senior management like rollout progress, employee demography, ageing of applications processing etc. for decision making.

• eService Book	• Tour
• Updation of Personal Information	• Transfer and Posting
• Leave	• Skill Upgradation/ Training
• LTC	• Vigilance
• Reimbursements	• Promotions
• Advances	

As a part of Phase I, the project has been rolled out in thirty ministries and departments encompassing a total of ~3800 Central government employees. The project is being rolled out in the subordinate and attached offices of the above thirty organizations. As a part of Phase II, project is being rolled out in fifty-four ministries and department.

9.5.10.6 E-Nivesh

e-Nivesh is a single window system for monitoring clearances required for setting up business/projects in India. The monitoring mechanism has been developed to fast track the pending clearance proposals beyond timeline at various Ministries/ Departments/Organizations of the Government of India and Governments of States/UTs. It aims at operationalizing a transparent, efficient and

convenient interface, through which government and businesses can interact and improve the business environment in the country for setting up investment related projects by enabling fast and efficient Government-to-Business (G2B) services.

The portal tracks all digitized proposals starting from the online submission till issue of clearance by pulling the essential information from various online Central and State level services/clearances portals. Project Monitoring Group, Cabinet Secretariat will monitor and resolve pending clearance proposals beyond timeline in the Tripartite Sub-Groups meetings involving various Ministries/Departments.

9.5.10.7 E-Samiksha

eSamikSha, an online Monitoring and Compliance Mechanism has been developed to fasttrack the compliance of pending action-points/proposals / issues/projects/schemes/targets, etc. of various implementing agencies such as Ministries/ Departments/Organizations of Government of India, State Governments, Autonomous Bodies, PSUs, etc. The system has been designed in such a way that it will enhance efficiency, bring transparency, save time and travel costs, bring accountability, reduce the need of protracted correspondence and improve the communication between Government to Government (G2G), Government to Business (G2B) and vice versa. It automates the tracking of action-points/proposals/issues/projects/schemes/targets, etc. starting from online submission to its compliance.

There is an increasing demand from other Ministries/ Departments/Organization to replicate eSamikSha System for Monitoring in their attached/ subordinate offices, public sectors, societies/association and autonomous bodies. Apart from central eSamikSha, it has been replicated for more than 42 Ministries/ Department / State / PSU / Autonomous bodies/ District etc. and various requests are in pipeline.

9.5.10.8 E-Suvidha

eSuvidha, an Online Projects Management System has been developed using Open Source Technology for tracking projects. It automates the entire tracking of stalled investment projects in the context of the bottlenecks. This includes submission of a new project, editing/updating the projects, reviewing the projects, submission of details relating to bottlenecks, Sub Group Meetings and decisions taken to remove the implementation bottlenecks.

The System also assists in preparation of Agenda and Minutes of the meeting, various Graphical Reports for analysis and tracking Investment in resolved projects.

9.5.10.9 Parivesh

'PARIVESH' is a Single-Window Integrated Environmental Management System, developed in pursuance of the spirit of 'Digital India' and capturing the essence of "minimum government and maximum governance". A workflow based application has been rolled out for online submission, monitoring and management of proposals submitted by project proponents to the Ministry of Environment, Forest and Climate Change (MOEFCC), Government of India as well as to the State Level Environmental Impact Assessment Authorities (SEIAA) to seek various types of clearances (e.g. Environment, Forest, Wildlife and Coastal Regulation Zone Clearances) from Central, State and district-level authorities. It automates the entire process of submitting the application and tracking the status of such proposals at each stage of the processing.



9.5.10.10 Bio Metric Attendance System

Digital India's Aadhaar Enabled Biometric Attendance System (AEBAS) Project has been established and rolled out in September 2014 in Government of India and extended to all State Governments successfully from March 2015. It is an enabling system to register an employee's attendance by presenting his/her biometric (Fingerprint/Iris), which is authenticated online within seconds in real time with UIDAI records. The Cloud-based software is installed and operated from NIC National Data Centre. Front end system is the BAS tablets or the desktop devices. The connectivity of terminals/devices is established through Wi-Fi/LAN with Internet, Broadband or SIM based GSM connectivity on tablets.



AEBAS is made highly scalable and caters to various type of requirements with respect to Ministry scheme beneficiary verification and attendance, eg. Skill Development trainees, Culture Ministry "Gurus", Sports Authority coaches and athletes, and so on. AEBAS Dashboard & awareness workshops were conducted for representatives of Centre and States for Nodal Officers, Users and support engineers of Organizations across the country, face to face and through VC. 24x7 Helpdesk team is available at NIC to users. Various monitoring mechanisms have been enabled and are monitored online with SMS facilities on the health system of all AEBAS Servers and functions. Timely updates and enhancements

with necessary security features in accordance with UIDAI's security guidelines are being incorporated into the system for safety and smooth process.

9.5.10.11 e-Taal

Electronic Transaction Aggregation & Analysis Layer (eTaal) is a platform which provides near to real-time aggregated view of eServices being delivered PAN India through various levels of government and other entities. It also provides a consolidated view of eTransactions performed through eGovernance applications across the eServices. The URL for accessing eTaal portal is <https://etaal.gov.in>.

eTaal has been in nation-wide operation since 1st January 2013 and approx. 3,784 eServices from 21 Central Ministries and 36 States and UTs have been integrated to the dashboard with over 14,705 crores eTransactions recorded as on 31st December, 2019 since its inception.

9.5.10.12 Automated Performance Smart-board of MeitY

The Government at various levels is placing a lot of emphasis on providing the benefits of various developmental schemes and programmes to citizens in an easy, efficient and transparent mode, using state-of-the-art IT tools and facilities. In order to have an effective monitoring mechanism for proper planning, decision-making and coordination till last mile, it is important that the interface to the information pertaining to such important programmes/ schemes, along with their Key Performance Indicators (KPIs), be placed on a common integrated dashboard with associated data and drill down facilities for viewing by senior government officials. This will help to measure the outcome and impact of the projects facilitating appropriate decisions and actions. The identified data could be integrated

on dashboards using APIs for various software applications/portals.

MeitY Performance Smart-board has been designed and configured by using NIC-developed generic dashboard application tool, which is used to rapidly prepare and deploy dashboard for respective Ministries/ Departments. The configurable and integrated dashboard displays information of important programmes/schemes in an objective and quantifiable way, thereby enabling a comprehensive view of MeitY projects in a single window. The Smart-board has month-wise and year-wise achievements of various programmes of MeitY. The major programmes are Aadhaar, Digital Payments, eTaal, BPO Promotion Scheme, Common Services Centre, Digital Literacy, DigiLocker, UMANG, NCoG, ServicePlus, eHospital, eProcurement, Open Government Data, eScholarship, MyGov, MeghRaj, Electronics Manufacturing and Skill Development Initiatives. It has been linked to various Programme Divisions' web servers to get the updated data automatically at the end of every month/year through web services.



Shri Ravi Shankar Prasad, Hon'ble Minister for Communications, Electronics & Information Technology and Law & Justice launching Smart-board

Automated Performance Smart-board of MeitY was launched by Shri Ravi Shankar Prasad, Hon'ble Minister for Communications,

Electronics & Information Technology and Law & Justice, during a programme held in Electronics Niketan, New Delhi on 3rd October 2019.



Dr. Neeta Verma, DG, NIC with other senior officials of MeitY present at the launch



Performance Smart-board Snapshot

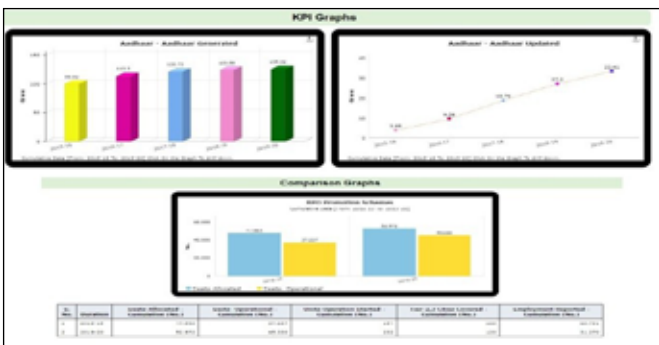

KPI & Comparison Graphs

9.5.11 E Governance Applications

9.5.11.1 Immigration, Visa and Foreigners Registration & Tracking (IVFRT)

IVFRT has led to the technological transformation of Immigration & VISA process by providing a secure and integrated service delivery framework

to facilitate legitimate travelers. It has enabled authentication of traveler’s identity at the Missions, Immigration Check Posts (ICPs) and Foreigners Regional Registration Offices (FRROs)/Foreigners Registration Offices (FROs) through use of intelligent document scanners and biometrics, updation of foreigner’s details at entry and exit points, improved tracking of foreigner’s through sharing of information captured during visa issuance at Missions, during immigration check at ICPs, and during registration at FRRO/ FROs.

The purpose of the e-visa service has been extended by adding e-medical attendant visa, e-conference visa and e-tourist visa (One Month, One year and Five years). Visa-on-Arrival service has been extended to the nationals of South Korea and UAE. e-FRRO Service has been introduced for all FRROs and FROs across the country. Dera Baba Nanak (Kartarpur) Corridor project has been implemented with the release of Praksahpurb550.mha.gov.in portal and Immigration Check Post.

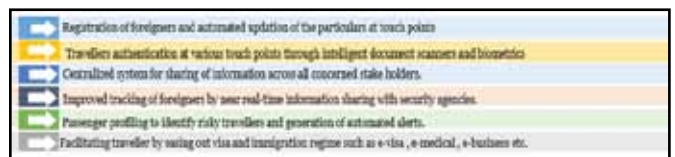

9.5.11.2 India Portal

India Portal, a Mission Mode Project that provides a ‘single-window access’ to information and services that are electronically delivered from all Government departments, institutions and organizations. It has been a popular source of information to a wide range of stakeholders - from citizens, to government, business and Indian Diasporas. It is a gateway to access Indian Government websites at Centre, State and district levels. The portal is also integrated with PIB, DD, AIR, MyGov and Open Data Platform to present the citizen engagement activities and open data across various sectors. The National Portal has over 2.5 million visitors per month (5.4 million-page views) and 4.25 lakh

registered users. National portal keeps the users updated by sending monthly newsletters. Important government events / activities are showcased through monthly spotlights. Portal also has a social media presence.

Other initiatives/ activities under the aegis of India Portal are: Guidelines for Indian Government websites (<https://web.guidelines.gov.in>), Digital India Awards (<https://digitalindiaawards.gov.in>), National Government Services Portal (<https://services.india.gov.in>), Know India (<https://knowindia.gov.in>).

9.5.11.3 My Gov

MyGov platform has been able to provide the citizens a voice in the governance process of the country. The platform has also created grounds for the citizens to become stakeholders not only in policy formulation but also in implementation through actionable tasks and discussions.

In the year 2019-20 MyGov Platform has crossed One crore registered users mark. During the year MyGov State Instances like Jharkhand (<https://jharkhand.mygov.in/>) and Nagaland (<https://nagaland.mygov.in/>) were also launched. Till December 2019, 60 ‘Mann Ki Baat’ episodes have been on air. Other significant activity include 5 Years (<https://5years.mygov.in/>) of Government performance, Swachhata Hi Suraksha, 2019 for Ministry of Defence (<https://swachhbharat.mygov.in/mod>), New India (<https://newindia.mygov.in/>), Transforming India (<https://transformingindia.mygov.in/>), Pariksha Pe Charcha 2020, India Innovation Challenge Design Contest 2019, The Gandhian Challenge, UNICEF Challenge, Youth Parliament Challenge, MyGov Quiz (<https://quiz.mygov.in>) hosts quizzes such as Padma Award 2019, Science Quiz, Paryatan Parv 2019,

Entrepreneurship Quiz 2019, Moniya Se Mahatma Tak Quiz, ISRO Quiz, Gandhi Quiz, Quiz on Elections in India and International Women’s Day Quiz, etc.



9.5.11.4 Open Government Data (OGD)

Open Government Data (OGD) Platform India (<https://data.gov.in>) is developed under the aegis of National Data Sharing and Accessibility Policy (NDSAP), serve as a single window Platform to host datasets from Central Government Ministries/ Departments. Developed using Open Source Stack, the project is one of the initiatives under Pillar 6 (Information for All) of the Digital India initiative. OGD Platform regularly conducts events like Data Hackathon, Challenges, and Workshops etc. for promotion, data utilization and public engagement.

OGD Platform is also available as Software as a Service (SaaS), which can be utilized to create own Open Data Portal. Till date dedicated State data portal instances of Sikkim, Odisha, Tamil Nadu, Punjab, Kerala have been created. Smart City Mission has also launched dedicated open data portal for 100 Smart Cities using OGD SaaS.

Items	Year 2016	Year 2017 (Cumulative)	Year 2018 (Cumulative)	Year 2019 (As on 13 th December)	% age of Growth from year 2016 to 2019
Open Datasets Published	50,296	1,51,067	2,54,408	3,40,542	669%
Datasets Contributing Departments	103	100	163	184	159%
Visualizations Created on Datasets	991	1,288	1,551	1,800	180%
Data APIs Created	444	3,592	10,755	21,761	4908%
Nominated Chief Data Officers	111	174	200	280	218%
Viewed	91,00,000	1,44,00,000	2,00,00,000	2,53,30,000	278%
Downloaded	36,00,000	53,00,000	84,00,000	77,00,000	214%

9.5.11.5 National Power Portal

National Power Portal fulfills the vision of Ministry of Power, Government of India to create a single source of power distribution across the country. NPP (<https://npp.gov.in>) is a centralized system to facilitate online data capture (daily, monthly, annually) from various generation, transmission and distribution utilities (e.g. NTPC, NHPC, Powergrid, DISCOMS etc), It disseminates information on capacity, demand, supply, consumption through various analyzed reports, graphs, statistics at all India, region and state level for central, state and private sector.

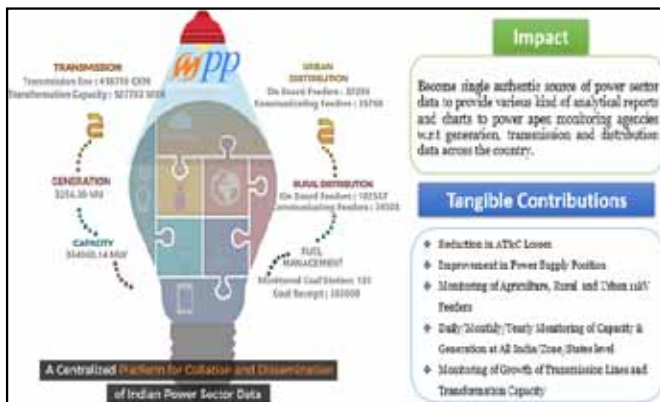

Dashboard provides visualization of analyzed information about the sector through GIS enabled navigation and chart windows on Capacity (installed, under maintenance, online), Generation (demand vs supply), Transmission network, Distribution system (Billing, Collection efficiency, Aggregated Technical & Commercial Losses (AT&C) at national, state, DISCOM, town, feeder level.

The Dashboard serves as a single point interface for all Power Sector Apps launched earlier by the Ministry such as TARANG (for transmission network), UJALA (for LEDs and appliances for all), VIDYUT PRAVAH (prices and availability from power exchange), SAUBHAGYA (electricity for every household), URJA (AT&C Loss), MERIT ORDER DESPATCH (for optimization of cost of generation of power plants by ranking units in order

of their cost of production). Coeus Age and Micro Focus selected National Power Portal for Gems of Digital India Awards 2019.

9.5.11.6 Platform for Effective Enforcement for No Child Labour (PENCiL)

PENCiL connects Ministry of Labour & Employment with 20 States, 284 Districts Project Societies with 3000 Special Training Centres (STCs) for effective enforcement for “No Child Labour”. It sets baselines based on key performance indicators at the levels to monitor physical and financial progress report. The platform captures children identified and rehabilitated through STCs and skill development depending on age group and nature of industry from where the children have been rescued. The portal facilitates reporting of child labour incidents followed by First Action Report (FAR) within 48 hours and subsequently Second Action Report (SAR) with 21 days, if required. Afterwards, if required Legal Action Report (LAR) is also recorded.

Now the portal is enhanced to capture daily attendance along with group photograph of children attending the school. The captured attendance is approved, on daily basis, by Project Director (PD), and the stipend payment will be made to eligible children on basis of attendance marked. The portal is under integration with PFMS for DBT.

9.5.11.7 Jan ShikshanSansthan

Jan ShikshanSansthan Scheme(JSS) portal aims to provides one common interface to all the stakeholders such as Management of MSDE/DJSS, State government department, JSSs parent and implementing NGOs, Aspirants, trainees-registered-trained-certified-placed, Assessment agencies, Recruitment and collaborating agencies etc. under one system.

JSS scheme is being implemented through NGOs having unique ID of Darpan-NITI Aayog

portal with annual recurring grant from the Govt. of India. Currently 248 JSSs covering over 27 States and 2 UTs in the country are functional and soon will cover each district of the nation. The scheme focuses in imparting/upgrading skill training to the socio-economically backward and educationally disadvantaged group by providing them market relevant skill sets and livelihood creation opportunities which makes them at par with all groups of society. The training is provided in non-formal sector to rural and urban slums with academic and technical support to its target group at the doorstep of the beneficiaries in the unreached areas of the country.

9.5.12 NIC in States/UTs

NIC has been associated with design and development of software for improving delivery of services undertaken by government departments at State and District level. ICT infrastructure of NIC viz. NICNET, NKN, LAN, Mini Data Centre, Video conference studios, messaging service, Webcast facilities are the key constituents of NIC services across all 37 States/ UTs and 720+ Districts. In order to design, development and implementation of various eGovernance initiatives and Digital India programme, NIC State Centres along with their respective District Centers are continually engaged to automate and accelerate eGovernance processes in close interaction with Government Departments.

9.5.13 Development of North Eastern Region (DoNER)

ICT solutions for schemes viz. NLCPR (Non Lapsable central Pool of resources), NESIDS (North East Special Infrastructure Developmental Scheme), 10% GBS (**Earmarking 10% of Annual Budgets by Central Ministries for the North Eastern Region**), ASIAN DEVELOPMENT BANK ASSISTED NORTH EASTERN STATES ROADS INVESTMENT PROGRAMME (NESRIP), Special

packages for BTC, KAATC, DHATC, HADP, SIDF etc. have been developed and operationalized for Ministry of DoNER.



9.5.14 NICS I

National Informatics Centre Services Inc. (NICS I) is a Section 8 Company (erstwhile Section 25 Company), a Government of India Enterprise under National Informatics Centre (NIC), Ministry of Electronics & Information Technology (MeitY). Its services include resource provisioning i.e. support for procuring and operationalizing state-of-the-art ICT infrastructure viz. hardware, networking etc.; Data Centre Services, facilitating Project management, software design & development, GIS services, roll-out support, facility management, Help Desk operations etc. Some of the prestigious projects include National Data Centre at Lakshmi Nagar, New Delhi, enhancement of NIC Cloud Services, National Data Centre at Shastri Park, New Delhi, National Knowledge Network (NKN), enhancement of NIC Cloud Services, facilitating various projects like e-Procurement, e-Office, e-Hospital, Aadhaar Enabled Bio-Metric Attendance System, Jeevan Praman, e-District etc.

Apart from adding new clientele and further strengthening various Projects, NICS I established a State-of-the Art Centre of Excellence for Data Analytics (CEDA) at its Office in Bhikaji Cama Place, New Delhi. Major projects include analytics

in the areas of Foreign Trade for Department of Commerce, eWay Bill for GSTN, Scholarship for Ministry of Tribal affairs, IVFRT for Ministry of Home Affairs, Property Registration, Public Distribution System for Gujarat etc.

NICSI achieved another milestone by setting up a Product Business Division (PBD) at its Office in New Delhi, with an aim to productize, standardize and promote Software Products developed by NIC/NICSI at International Level, particularly the countries in South Asian Region having similar legacy and background. NICSI signed Agreement with Mauritius Prison Service for ePrison Phase I and Phase II. Several foreign countries have expressed interest in NIC/NICSI Software Products including Morocco, Kyrgyzstan, Sri Lanka, Thailand, Venezuela etc.

9.5.15 International Collaboration

NIC is collaborating with number of countries for fostering bilateral and multilateral ICT cooperation in the area of eGovernance products and services which are generic, configurable, built with cutting edge technologies and could be replicated in other countries. NIC's eGovernance Product and Services were showcased in meetings held with high level delegations of Kazakhstan, Morocco, China, Kyrgyzstan, Uzbekistan, Denmark, Indonesia, Bangladesh, Venezuela, Zimbabwe, Japan, Czech Republic and Latvia for a future bilateral cooperation. Follow-up of initiatives was undertaken for a future collaboration on eGovernance with Zambia, Bulgaria, Taipei and Ethiopia. The first capacity building programme exclusively for NIC Officers on International best practices and case studies on eGovernance with emphasis on emerging technologies from world renowned Institutes was planned and initiated.

The eGA Estonia was approved by higher authorities after comparing proposals from The London School of Economics, University of Melbourne, University

of Singapore and eGovernance Academy, Estonia. Explored the Institutional Research Collaboration between NIC and United Nations University Operating Unit on Policy-Driven Electronic Governance (UNU-EGOV), Portugal. Coordination of participation of NIC/NICSI to showcase NIC eGovernanceservices and products in 5th edition of Global Exhibition on Services (GES), 2019 at Bengaluru, with delegates from 74 countries. Participation in India-Europe 29 Business Forum, New Delhi 2019 to promote NIC's eGovernance Applications with delegates.

Relevant Inputs provided to

- Possible agenda items for the India's G20 Presidency in 2022
- CHOGM 2018 - Status of implementation of mandates and deliverables
- G20 DETF Good Practice on Governance Innovation and Repository.
- 141st Ministers Assembly of Inter-Parliamentary Union (IPU) to be held in Belgrade (Serbia).
- ASEAN Industry Issues for ASEAN Economic Meeting September 2019-Bangkok, Thailand. Inputs for Quarterly Rolling Plans. Coordinating the productization of identified eGovernance products for International market.



9.5.16 Centre of Excellence (CoE) and Software Development Unit (SDU)

9.5.16.1 Data Analytics

Centre of Excellence for Data Analytics (CEDA) was established as a joint initiative of NIC and

NICSI with the vision of kick-starting and fast-tracking the adoption of advanced analytic and machine learning capabilities within Government.

As a part of its service offerings, CEDA helps government departments in centre and states in defining data analytic needs and possibilities utilizing available data, identifying the data sets that are required to meet the analytic needs, development and deployment of required data analytic solutions, providing consultancy over Data Analytics process and projects, exploring of multiple tools / technologies for Data Analytics, making available for Big Data technology as service over Government cloud and training and capacity building in area of Data Analytics.

CEDA is also in the process of developing a visualization tool for government using open source technologies; in addition, CEDA is also looking to create an Advanced Analytics platform for government. CEDA has also been conducting various training and awareness sessions for government officials in various institutions such as Indian Institute of Public Administration (IIPA), Indian Agricultural Statistics Research Institute (IASRI) and various officials of state governments. Now, CEDA is in the process of launching formal training programmes for government officials in the space of data analytics and machine learning in government.

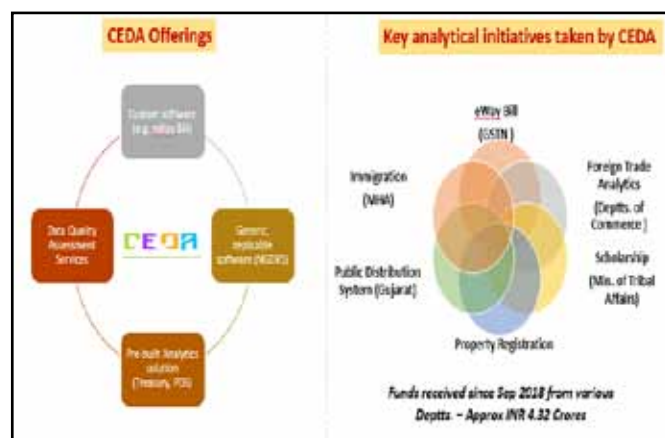

9.5.16.2 Artificial Intelligence

Centre of Excellence in Artificial Intelligence (COE-AI) - was inaugurated by Honourable Minister of Electronics & Information Technology, Shri Ravi Shankar Prasad in National Informatics Centre (NIC) Headquarters, on 10th January 2019. Its vision is to ensure that India is positioned to actively influence AI development path. NIC has setup a state of the art AI lab with supercomputing facilities and has been providing AI Development Platform as a Service to its's state units. It has also done capacity building of its officers with 1st batch trained in a 5 day residential programme at IIT Roorkee, Greater Noida Campus.

Social Inclusion using AI is one of the objectives that NIC has been working for. Towards that end it has worked with Ministries and Government Departments to provide conversational bots to facilitate Citizen interactions with Government in both English and Hindi in text and speech. To provide these bot services, NIC has come up with a generic framework called VANI (Virtual Assistant of NIC). Chatbot for RTO licenses has been released in October and is getting around 3 lakh hits/day. Chatbot for eVigilance Chandigarh is in production. More bots are in pipeline for Lok Sabha Secretariat, Niti Aayog, PDS Puducherry, CONFONET (Consumer Case Status), iKhedut (Bot in Gujarati & English for farmers), eWay Bill etc.

NIC has been working towards providing a Cognitive Search to assist Lower Judiciary. It has been decided to provide a language model-based search for 3 crore case outcomes which is available in unstructured pdfs which at present is not being harnessed.

In addition to conversational AI and Cognitive search, COE-AI@NIC is also working in various aspects of Image & Video Analytics. A mobile app was developed to facilitate citizens with toilet status

so that if the image uploaded is not correct, they can reload the photos and reduce the approval cycle and the final instalment transfer to their accounts. SwachhAI, an AI enabled mobile app based on the above model was recently launched by Hon'ble MOS(I/C) of Housing and Urban Affairs Sh. Hardeep Singh Puri on 13th August 2019.

9.5.16.3 Application Security

CoE in Application Security is established to provide state-of-the-art Security solutions & services for the Information Technology needs of the Government of India, and establishing best practices, standards and initiatives in Application security. The centres are located at Assam, Rajasthan, Bhubaneswar, Lucknow, Thiruvananthapuram.

9.5.16.4 NIC Software Development Units (SDU)

Software Development Units of NIC provide state of art services using latest tools and technology.

SDU Pune

E-Hakk (Public Data Entry) web based software application, Stamp paper inventory application, Vendor Portal, National Generic Document Registration System (NGDRS), Case Information System(CIS), eFiling portal, eCourts portal <http://ecourts.gov.in>, National Judicial Data Warehouse (NJDG), National Service and Tracking of electronic Processes and Virtual Courts are some of the major applications developed by SDU Pune.

SDU Kochi

Kerala Online Mining Permit Awarding Services (KOMPAS), MyCoir, CoirConnect, Digital Coir Board, Campus*Suite (Financial Accounting System), Campus*Suite for Maharajas College, CMS based website for Maharajas College, MISAGO, CMS based Web Portal for CIFTNET, CMS based Web Portal for Guruvayur Devaswom,

Nextmile (A Joint Publication by NIC &MoRTH), MeghRajCloud Administration are some of the major e-Gov solutions and applications implemented in Central and State Departments by SDU Kochi.

9.5.16.5 Open Technology Group

Open Technology Group (OTG) provisions support services for adoption of OSS in various eGovernance projects and applications. OTG focus areas are to evaluate and recommend open source software for e-Governance Solutions, maintain distribution repository of recommended open source software for usage across NIC, guide and handhold NIC teams in keeping their open source driven system secure and provide training on Open Source Software.

OSS Repository includes 126+ Tools, 685+ Major versions, 8902+ Minor versions. 18 awareness programmes and 1 class room based programme were conducted. OTG Won Silver Award in the TechGov 2019 for Design and PoC of Device Integrator, Any Type Hardware Management Architecture (ATHMA).



9.5.16.6 Lal Bahadur Shastri National Academy of Administration

NIC Training Unit, Lal Bahadur Shastri National Academy of Administration, Mussoorie provides

Information and Communication Technology related training to the officers of All India Services during all the training programmes conducted at the Academy. NIC provided ICT consultancy, project management, software development/ implementation support to ICT facilities including MyGov instance, and Thematic Group presentations before the Hon'ble PM during Common Foundation Course at Kevadia, Gujarat Artificial Intelligence (AI)/ Machine Learning (ML) demonstrations were conducted for IAS and NIC Officers for identifying crop diseases and Automatic Number Plate Recognition (ANPR).

APIs have been developed for integrating Eckovation's Adaptive Learning Platform with the LBSNAA's Learning Management System (LMS), and NICTU's on-line examination system with SARGAM ERP. Mobile Apps were launched for Inter-Services Meet (ISM) 2019 and SARGAM ERP On-line exams were conducted during the IAS Professional Course Phase I, 94th Foundation Course and 121st Induction Training Programme. The Hon'ble Union Minister of State, Personnel, Dr. Jitendra Singh launched the LBSNAA's Adaptive Learning platform for online courses on AI, Machine Learning, Blockchain and Data Analytics at LBSNAA, Mussoorie on 1st-Sep-2019



9.5.17 Major Events

9.5.17.1 Technology-Conclave

Spearheading celebrations on the impact of ICT on e-Governance, NIC hosted its first ever Technology Conclave at Pravasi Bhartiya Kendra, Chanakyapuri, New Delhi from 22nd to 23rd January 2019. Themed as "Technologies for NextGen Governance", the two-day event was organized to enable knowledge sharing on advanced technologies for project teams and government officials.

Shri Ajay Sawhney, IAS, Secretary, Ministry of Electronics and Information Technology, inaugurated the Conclave by lighting ceremonial lamp, along with Dr. Neeta Verma, Director General, NIC, Dr. Savita Dawar, DDG & Chair, TAG, NIC, and Dr. Anand Deshpande, Founder, Chairman and Managing Director, Persistent Systems.



The event witnessed an enthusiastic participation of NIC officers from all over the country and erudite speakers, the technology experts from the IT industry, who deliberated on various topics related to the application of emerging technologies.

9.5.17.2 Vision Insight and Voices as India goes Digital (VIVID)

The third edition of VIVID (Vision Insight and Voices as India goes Digital), the National Meet

on Grassroot Informatics, was organised by the National Informatics Centre (NIC) at Stein Auditorium, India Habitat Centre, New Delhi from 21st to 22nd February 2019. VIVID, an annual National Meet to conduct healthy interactions with NICians, includes District Informatics Officer (DIO) Meet and Awards Ceremony to reward the contribution of officers positioned at various District Offices across the country.

The event was inaugurated by Shri Ravi Shankar Prasad, Hon'ble Union Minister, Electronics & Information Technology and Law & Justice, along with Shri Ajay Sawhney, IAS, Secretary, Shri Pankaj Kumar, Additional Secretary, Shri Gopalakrishnan S., AS& FA and JS (Emerging Technologies), Smt. Simmi Chaudhary, Economic Adviser and Group Coordinator, MeitY, Dr. Omkar Rai, Director General, STPI, Dr. Neeta Verma, Director General, NIC.

Appreciating the efforts of DIOs and exhorting them to stay enthusiastic about their work, Shri Ravi Shankar Prasad said, "VIVID has been designed to empower and give you exposure."

9.5.17.3 Digital India Awards

Digital India Awards acknowledge exemplary and innovative initiatives of various government entities in the realm of Digital governance. The awards aim to spread awareness about such initiatives. National Informatics Centre (NIC) hosted the fifth edition of Digital India Awards at Stein Auditorium, India Habitat Centre, New Delhi on 22nd February 2019. Hon'ble Minister of Electronics & Information Technology, Law and Justice, Shri Ravi Shankar Prasad felicitated the winners. Three Awards - Platinum Icon, Gold Icon and Silver Icon have been conferred in eight categories. Two Jury Choice and Four Special Mention awards have also been conferred.

Total thirty-five awards were given under different categories. The Hon'ble Minister later released the awards compendium containing details about the award winning initiatives.

9.5.17.4 International Yoga Day

On 21st June 2019, NIC coordinated with Ministry of Ayush, New Delhi to celebrate 5th International Day of Yoga under the theme of "Festival of Yoga and Wellbeing". A Yoga workshop was organized at NICHQ, CGO Complex where the Sanghamitra team of NIC explained the benefits of Yoga and demonstrated various Yoga postures for living a healthier life. To ensure maximum benefit to NICians, VC and webcast facility was used to broadcast the event live across the country.

NICians in various Ministries, States and Districts attended the event through VC and webcast facility. 279 persons were connected through webcast.

Also, various NIC State Centres celebrated the day by organizing their own events and shared the information with NICHQ.





9.5.17.5 DSML-Dr. N. Seshagiri Memorial Lecture



Dr N. Seshagiri, Founder Director General of National Informatics Centre and former Special Secretary to Government of India, was the architect

of the Nationwide network NICNET and the DISNIC Programme in the country to usher in the ICT revolution in all the districts in 1987. He was the member convener of the prestigious National Task Force on IT to formulate National IT Policy to transform India into global software power and revolutionised IT in the country. To pay tribute to this great visionary, the First Edition of Dr. N. Seshagiri Memorial Lecture was organised by NIC, on 5th August 2019 from 3:00 PM to 5:30 PM at Vigyan Bhawan.

The lecture was delivered by Shri. Narayana Murthy, Founder - infosys Limited. Shri Sanjay ShamraoDhotre, Hon'ble Minister of State, Human Resource Development, Communications and Electronics & Information Technology, Shri Ajay Sawhney, Secretary, Ministry of Electronics & Information Technology, Dr. Neeta Verma, Director General, NIC and Dr. Savita Dawar, Deputy Director General, NIC were present on the occasion.

9.5.17.6 150 years of Celebrating the Mahatma

	<p>July 2019-E-Waste Management for Environment Conservation</p> <p>DG, NIC launched the 'Series of events for Commemoration of 150th Birth Anniversary of Mahatma Gandhi' from July 2019 to October 2020 on 30-07-2019 at NIC Hqrs. The first activity is the lecture on e-Waste Management for Environment Conservation. She welcomed the Guest Speaker Shri Rashid Hassan, Advisor SIAM, Former Advisor, Ministry of Environment, Forest and Climate Change on the occasion. Shri Inder Pal Singh Sethi, DDG, NIC and Shri Shiv Kumar, Scientist-F were also present on the occasion.</p>
	<p>August 2019- Relevance of Mahatma Gandhi's thoughts and teachings in Modern Times</p> <p>A lecture on 'Relevance of Mahatma Gandhi's thoughts and teachings in Modern Times' was delivered by Shri Laxmi Dass, Ex-Chairman, Khadi and Village Industry Commission (KVIC) on 26.08.2019 at NIC Hqrs., New Delhi. In his lecture, Shri Dass highlighted the principles of Gandhi Ji's life, his experiments of truth and meaning of Ahimsa (non-violence). He further explained about how we can inculcate the thoughts and teachings of Gandhi Ji in our day-to-day life by taking examples from Gandhi Ji's life. While concluding the lecture, he also briefed about the benefits of 'Naturopathy' to live long and healthy life.</p>
	<p>September 2019- Social Harmony</p> <p>A lecture on 'Social Harmony' was delivered by Shri Dipankar Shri Gyan, Director, Gandhi Smriti and Darshan Samiti, Ministry of Culture, Government of India, on 26.09.2019 at NIC Hqrs., New Delhi. The event was broadcast over NIC Video Conferencing services and was attended by officers up to District level. It was also available through NIC webcast services.</p> <p>Shri Gyan talked about Gandhi Ji's deep understanding of all religions, where he identified that the basis of all religions is only one thing, which is 'Truth'.</p>

	<p>October 2019-Life of Mahatma Gandhi</p> <p>DG (NIC) inaugurated the 'Book and Poster Exhibition on Mahatma Gandhi's Life' held on the 7th Floor, at NIC Hqrs. New Delhi on 2nd October 2019. Lamp lighting ceremony followed the inauguration of the event. The exhibition was organized in continuation of the special commemorative drive for 150th Birth anniversary year of Mahatma Gandhi.</p> <p>DDGs, HOGs and HODs attended the exhibition with enthusiasm along with their respective teams. DG and NIC officials later explored the exhibition and observed Mahatma Gandhi's journey from 'Mohan to Mahatma' through the knowledgeable posters.</p>
	<p>November 2019-Swachhta Abhiyaan</p> <p>An award distribution ceremony for various activities for Commemoration of 150th Birth Anniversary of Mahatma Gandhi was held on 07.11.2019 at NIC Hqrs., New Delhi. The Poster making competition on the theme of 'Swachhta Abhiyan and Water Conservation' was organized. Shri. Baldev Raj Kamrah emphasized on Gandhi Ji's ideologies on Harmony being implemented in the society. Dr. Shyam Sunder Agrawal, a world-renowned scientist with research experience of about 45 years was also present.</p>
	<p>December 2019-Social Service</p> <p>A winter clothes distribution event was organized by NIC Hqrs. on 08.12.2019. It was the 6th activity in continuation of events for the Commemoration of 150th Birth Anniversary, launched by DG NIC, in July this year.</p> <p>'Sanghamitra- Women Power of NIC' issued a circular on 'Winter Clothes Drive' requesting NICians to donate woollen clothes and accessories in good condition, which were collected at the Ground Floor at NIC Hqrs. from 18-29 November 2019.</p>

9.5.18 Media and Outreach

Brand NIC - its products & services, projects, apps, software application are highlighted and promoted on various social media platforms - Twitter, Facebook, LinkedIn, Instagram and YouTube.

Various events organized by NIC are shared on social media through live tweets, posts along with

the live webcast. Important events/programmes including states initiatives are covered on all digital platforms and print media. Short video/voice capsules of the flagship projects of NIC are publicized on Social Media platforms and on NIC's website. A film was made on Dr. N. Seshagiri, the founder of NIC and was screened during Dr.Seshagiri Memorial Lecture 2019.



9.6 Standardisation, Testing and Quality Certification (STQC) Directorate

9.6.1. Introduction

STQC Directorate is an attached office of Ministry of Electronics and Information Technology (MeitY), Government of India. A network of fifteen testing and calibration laboratories has been established by STQC Directorate in the country including

North-East region. STQC laboratories offer quality assurance services in the field of electronics and information technology including e-Governance applications. It has been following global best practices and obtained many national and international accreditations/recognitions.

A gist of Services offered and locations of laboratories/ centres are indicated below –

Laboratories/ Centres	Locations	Services offered
Electronics Regional Test Labs (ERTLs)	Delhi, Kolkata, Mumbai, Thiruvananthapuram	Testing and Calibration both for electronics and information technology.
Electronics Test & Development Centres (ETDCs)	Bengaluru, Mohali, Hyderabad, Chennai, Guwahati, Pune, Goa, Agartala, Jaipur, Solan, Ajmer	(IT testing activities are taken up at all labs except Mumbai, Goa, Solan and Ajmer)
Centre for Reliability	Chennai (Co-located with respective ETDC)	Reliability testing
Indian Institute of Quality Management (IIQM)	Jaipur (Co-located with respective ETDC)	Training courses on Quality Management, Information Security, Website Quality Testing etc.
Regional Certification Centres	Delhi, Kolkata, Mumbai, Bengaluru (Co-located with respective ERTLs/ ETDCs)	Certification services for Quality Management and Product Safety

2. Major Achievements during FY 2019-20

Major services offered – Information Technology (IT)

STQC IT centres have successfully executed testing and assessment of the number of e-Governance, Defence, Space and IT Projects of Central and State Governments. Some of the major jobs undertaken are indicated below -

Services offered	Name of the Project
IT / Security Testing	<p>ERTL-North, Delhi</p> <ul style="list-style-type: none"> Assessment of Pre-certified hardware used with UIDAI L1 device Audit of Cyber Forensic Labs (Central & State) for notifying as examiner of Electronic Evidence as per u/s 79A of IT Act, 2000 Common criteria evaluation of Operation, Administration and Management of module of Voice and data multiplexer & Cygnet OSS software Feasibility study of Cryptographic Module Validation programme and National Common Mobility Card Mobile Application security testing of Samvaad (C-DOT), Election Commission of India, Income Tax Department, Department of Post

Services offered	Name of the Project
	<ul style="list-style-type: none"> • Testing & Evaluation of Major Central & State level e-Governance projects for Cyber Security Compliance like - <ul style="list-style-type: none"> o EPFO, o NDMC, o BCAS Key management system, o GSTN, o MCA-21, o Income tax department, o Ayushman Bharat, o GeM, o GePNIC, o Election Commission of India, o Delhi Excise Department, o e-Lottery system (Forest Department of UP Govt.), o E-Procurement System (BSNL, C1 India, RITES, NPCIL, EESL, DRT, EPTL) o Integrated Air Command & Control System of Indian Air Force o SLA Audit of Ministry of External Affairs. <p>ERTL-East, Kolkata</p> <ul style="list-style-type: none"> • Annual Security (ISO/IEC 27001:2013), Quality (ISO/IEC 9001:2015) and IT Service Management (ISO/IEC 20000-1:2011), Audit for 'Passport Seva Project' which includes assessment of functional changes (CCNs), Process Security, Infrastructure Security, DC-DR failover Capability and Penetration Testing. Also conducted assessment for strategic controls like SLA management, Exit management etc. of Passport Seva program. • Conformity assessment of e-Procurement and e-Auction platform of different organizations. The systems are successfully used in different e-Auction exercise of Govt. of India. • Functional Testing, Performance Testing and Security Assessment of different modules [Centre and State, Online/Offline application] of National Crime Research Bureau (NCRB) applications. Assessment completed for some of the modules, remaining are in progress. • Cloud infrastructure audit of GEM application and suggested many improvements. • Security Assessment of Online Lottery Software, including assessment of Randomness of their RNG source, for State of Nagaland and Bodoland Territorial Council, Assam. • Functional and Security testing of online examination application of a leading software company. • MeitY's empanelment audits for Cloud Service Providers (CSP) • Security vulnerability assessment conducted for the websites of some of Mission offices of Govt. of India. • About 60 Web applications/ websites from different departments of State Government have been assessed for security vulnerabilities and cleared for 'safe to host' • Initial security assessment for about 50 Web applications/web sites from different organization and waiting for closures (by the developers) to issue final clearance. • New service Started for Security Assessment of Mobile Apps for Android against the security requirements of OWASP for L1.

9.6.2 Common Criteria (CC) Testing Infrastructure

Common Criteria Security Test/ Evaluation Laboratory as well as a Certification Scheme based on Common Criteria standard have already been established at ERTL(East), Kolkata, ERTL(North), Delhi and ETDC(Bengaluru). The Common Criteria Test Laboratories are operational. There is a need in the market to evaluate the product. Following services have been provided by ERTL-East :

- Common Criteria (CC) testing laboratory has completed EAL 4 CC evaluation activities for the Security framework of Command & Control System of Indian Air force, which in real time responses/ remediation of threats across the Indian Air Space.
- Common Criteria (CC) testing laboratory has completed EAL 2 CC Evaluation for ADVA FSP300R7, a fibre supported platform used in long haul telecommunication infrastructure.
- CC testing laboratory is also conducting EAL 4+ CC evaluation of a Certificate Authority (CA) server and CC evaluation of Tele communication network elements.

9.6.3 National facility for Quality Assessment of Biometric Devices

In order to eliminate the use of stored biometrics, UIDAI has mandated the use of registered devices for Biometric authentication. Before deployment of Registered Biometric devices in the field, Hardware and RD services of the Registered Devices have to be certified by STQC. As part of certification, ETDC-Bengaluru has evaluated 115 Registered Devices for 35 vendors as per UIDAI technical specifications Ver 2.0. Based on the evaluation report, 109 Registered Devices pertaining to 35 vendors have been provided with provisional certificates.

9.6.4 Website Quality Certification Services

Website Quality Certification Scheme based upon national and International standards / best practices

aims to help in hardening of websites from wide range of Security threats, increasing accessibility, assuring commitment to services and ensuring compliance to the requirements of Guidelines for Indian Government Websites (GIGW).

The award of the mark “Certified Quality Website (CQW)” is a recognition that the website complies with the requirements of GIGW and the organization has adequate procedures and processes in place to provide reliable and dependable information and service through their website. Under the Website Quality Certification Scheme, 252 websites have been certified.

9.6.5 Major Services Offered - Testing and Calibration

STQC laboratories have provided test and calibration services to a large number of industry, public sector undertakings and Government organisations. Some of the major testing and calibration jobs undertaken during the period are indicated below -

Lab name	Services offered
ERTL-North Delhi	<p>Safety testing</p> <ul style="list-style-type: none"> • Energy Meter for S-Mark Scheme as per IEC 62052-31 • Lung Ventilation Device as per IEC 60601-1, • Pulse Oximeter as per IEC 60601-1, • HB Hemometer as per IEC 61010-2-101 • Patient Monitor as per IEC 60601-2-49 in conjunction with IEC 60601-1 • RFID Tags and Terminal Blocks as per RDSO requirement <p>EMC Testing</p> <ul style="list-style-type: none"> • Truscult Flex (IEC 60601-1-2) • Neubie (IEC 60601-1-2) • IPG Optical Amplifier (IEC 60870-2-1) • Power Line Carrier Communication System • Wheel Slide Protection Device • Patient Monitor Reco Bro Vigile with Record View • Bank Note Processing Machine

Lab name	Services offered
ERTL-East Kolkata	<ul style="list-style-type: none"> • Upgradation of facility for Calibration of Avionics equipment of Air Traffic Control by acquired VOR/ILS Instrument System. • Received NABL accreditation of calibration facility as per revised ISO/IEC 17025:2017 with range extension in `Energy` calibration and CMC improvement in `Power Factor` calibration. • Safety testing of Single & Three Phase Energy Meters (Smart Meters) as per IEC 62052-31 for STQC `S` Mark Scheme, • Safety testing of Single and Three Phase Static Energy meters under STQC `S` Mark scheme as per IEC 61010-1:2010, 3rd Edition. • Safety testing of IT products like Automatic Data Processing Machines, Power Adapters, Mobile Phones, Self-Ballasted Lamps, UPS, VDU etc. as per relevant BIS standards under CRS/ Surveillance scheme of BIS and MeitY. • Type testing of Energy Meters & Tri-Vector Meters of various types up to 100A (Imax) for major Indian manufacturers under Licensing Scheme of BIS and requirements of Electricity Boards across the country. • EMI/EMC testing for limited parameters as per RDSO Standards for various Signalling and Power Electronic Products to be used for Indian Railways and also completed EMI/EMC testing for Power Supply, Level Controller, industrial products etc. as per IEC 61000/ CISPR standards. • Testing of LED based Solar Lighting System, Battery and PV Modules as per MNRE, BIS and IEC Standards. • Climatic conditioning, Mechanical endurance & Ingress Protection tests on Electrical & Electronic Equipment/System for Telecom, Defence, Railway & other Industrial applications. • Testing & certification of Electrical Equipment intended to be used in potentially hazardous atmospheres in underground Coal/Oil Mines and Surface Industries dealing with hydro-carbon and other combustible materials as per IS/ IEC 60079 series for BIS, DGMS & PESO approval.

Lab name	Services offered
ERTL- West, Mumbai	<ul style="list-style-type: none"> • Safety evaluation of Tablet tester, Clinical Chemistry Analyzers as per International Standard. • Evaluated Tablets, Mobile Phone, LED Driver, Automatic Data Processing (ADP) Machine, Date Projector for Safety requirement under CRS Scheme of MeitY. • Evaluated Twin Beam LED Head Light luminaries for EMC requirement to be used to illuminate locomotive tracks, track side indication, OHE masts and any obstruction/ abnormality on the track. • Evaluated indigenous Electronic Fan Regulators, Static Energy Meters, Prepaid Energy Meters and Dry Batteries as per applicable IS Standard for BIS under their ISI Mark scheme. • Obtained accreditation from TEC, Department of Telecommunication, Govt. of India as a conformity assessment Testing Laboratory for testing various DOT products. • Obtained accreditation from NABL in the area of Testing and Calibration. • Bureau of Indian Standards has continued ERTL-West recognition as an approved Test Laboratory. • Testing of Indigenous manufactured LED light fixtures completed successfully, fixtures have been deployed in the Central and Western railway suburban network. • Testing of Indigenous manufactured products such as Ammunition handling control panel, Gunner firing pendant, Motor driving box, Power distribution unit etc. having vital role in Indian Defense. • Reliability testing of `Unmanned Aerial Vehicle (UAV), having its end use in strategic defense application. • Environment stress screening of Printed Circuit Boards carried for number of industries having an application in Defense. • Calibration services to avionics industries in western zone for calibration of instruments. • Certification of Cloud Service Providers (CSPs) as per MeitY's scheme was undertaken and completed. • QR code Scanners have been tested as per MeitY's scheme for UAIDI biometric authentication.

Lab name	Services offered
ETDC-Chennai	<ul style="list-style-type: none"> Tested Numerical Line Differential protection relay for Power Grid Application - Protection for overhead lines and cables, Transformers, to ensure the power grid continues to supply energy in case of isolated equipment faults. The Protection Relay is used to detect the fault occurrence and to isolate the faulty equipment. Risk of shock from the faulted equipment is thus minimized. Testing of IoT based Irrigation Valve Controller to control and monitor pump sets and irrigation gate valves through mobiles by time and volume based. It increases production, reduces water consumption and man power and much land can be irrigated. Tested Microprocessor based Fire Alarm panel as per RDSO standards, which is used to detect fire/ fire like situation in relay room, Power Equipment room, DG set room, and other rooms pertaining to signaling installation and generate audio visual alarm. Evaluated and tested the advanced night-vision device (NVD), also known as night optical/observation device (NOD) and night-vision goggles (NVG) for INSAS Rifles, which is an optoelectronic device that allows images to be produced in levels of light approaching total darkness. Tested Porcelain clad vacuum circuit-breakers, designed & manufactured for outdoor applications for Switching & Protection of Medium Voltage Distribution networks keeping in view the tropical climate, simple construction and less number of moving parts to ensure reliable service and safety. Application Security testing of PM Memento's web portal. PM Mementos is an Open Auction portal of Government of India, that provides a platform for prospective buyers to participate in the online auction for the items in display after due registration. First time STQC has taken up conformity assessment of Smart City Project, PSCDCL, Pune under the Smart Cities Mission, Govt. of India. The conformity assessment included review, audit and field testing on the vulnerability of primarily the Network of smart elements like IoT devices, flood sensors, environmental sensors, variable message display signs, public address system and Wi-Fi access points.

Lab name	Services offered
CFR-Chennai	<ul style="list-style-type: none"> Reliability Prediction Analysis was carried out for Advanced Light Weight Torpedo, for Naval Science and Technology Laboratory, Vizag. It is an anti-submarine torpedo launched by ship, fixed and rotary wing aircrafts. The work involved mission based reliability block diagrams and stress details of various parts and sub-systems of the Torpedo based on which the MTBF is estimated. Reliability assessment of UPS Regalia 1500VA was carried out. This system is a Wall Mounted, Home UPS, which uses Lithium ion batteries for which the Reliability characteristics like MTBF, Failure rate, etc., are estimated.
ETDC-Hyderabad	<ul style="list-style-type: none"> Software verification testing of machine controlled and homing system of Varunastra system at NSTL Vishakhapatnam Cloud Computing Empanelment Audit for 3 cloud service providers at Hyderabad and Mumbai Calibration of Digital programmable DC Power Supplies (Qty.: around 450 nos.) for RCI and DRDL
ETDC-Goa	<ul style="list-style-type: none"> Goa Shipyard Ltd., Mormugao Port Trust, Nuclear Power Corporation Ltd., Indian Navy, Airport Authority of India Ltd., Indian Arctic Research Centre, Indian Oil Corp. Ltd., HPCL, ONGC, District Hospitals of Govt. of Goa, etc.
ETDC-Pune	<ul style="list-style-type: none"> Control Panel with Engine Super Fold BFC Pressing Unit Junction Control Unit Knife Paper Fold Machine Alarm Annunciator SMPS Elisa Well Washer Washing Machine Pressure Transmitter Power Cum Control Unit Electro Surgical Unit Curtain Controller Automation relay Bed Head Unit Blood Glucose Monitoring System

9.6.6 Medical Safety Test Facility

Medical Electronics lab of ERTL-South is the lead lab in the country for testing medical electrical equipment. It has got accreditation for testing medical electrical equipment as per IEC 60601-1 3rd edition for defibrillator, Electro cardiograph, Bed side monitors and high frequency surgical diathermy .

The latest testing includes safety testing of wearable ECG device which can replace clinical ECG for monitoring of patients in a large hospital setup where the patient volume is huge. This device is up-gradable to IoT enabled one.

9.6.7 Continuing participation in Space Programmes through Components Screening, Packages & Modules Testing and Environmental Testing

Components:

ERTL (South), Thiruvananthapuram has carried out screening of components which includes discrete devices, high frequency Pulse transformers, Low voltage crystal oscillators, ICs (digital & linear in different packages, Leaded as well as SMDs) for Indian Space Research Organization units viz. Vikram Sarabhai Space Centre (VSSC) and ISRO Inertial Systems Unit. Lab has developed test set-up for low voltage integrated circuits which are mainly SMD devices for deployment in Small Scale Launch Vehicles which saves power consumption and space (miniaturization).

Contributed actively by screening of electronic components for Chandrayan mission. Qualification tests are being carried out regularly for different types of components for space application. The lab has carried out screening of RTD sensors and new types of Transient Absorption Zeners. Identified by VSSC as major test centre for screening of SMD devices. Started developing test facility for components used in Gaganyaan mission which is scheduled for 2021-22.

Environmental

- Screening of Isolators used for mounting various electronic packages used in GSLV/ PSLV launch vehicles.
- ESS for various PCBs for Defense related projects.
- Our Vibration Test facility is regularly utilized by VSSC and its ancillary units for testing their packages and modules as per space specification.

Equipment

Testing and evaluation of Navigation, Guidance and Control (NGC) packages of launch vehicles is in place. Command Execution Modules (CEM) and Selection Logic Relay Unit (SLRU) have been evaluated. Continuing test & evaluation of ATS Stacks, Power modules and Data Acquisition Units used in GSLV/ PSLV. Actively contributed for Chandrayan Mission by way of test and evaluation of packages used in the Mark III Vehicle.

9.6.8 EVMs and VVPATs testing - ETDC, Bengaluru and ETDC, Hyderabad

Election Commission of India (ECI) identified STQC Directorate. as an independent test agency and issued work order for third party testing of large number of ballot units and control units manufactured at BEL Bengaluru and ECIL Hyderabad.

ETDC Bengaluru and ETDC Hyderabad have tested VVPAT machines, Ballot Units & Control Units for functional, electrical, environmental, EMI/ EMC and mechanical compliance of the products as per standards & quality process and sampling procedure set by the Technical Evaluation Committee of ECI.

9.6.9 Major Service offered - Training

Indian Institute of Quality Management provides training to industries and organisations in the area of Quality Management System (ISO/IEC: 9001),

Laboratory Quality Management System (ISO/IEC: 17025), Information Security Management System (ISMS) (ISO/IEC: 27001). Following trainings have been provided by STQC labs -

Lab name	Training offered
ERTL-North	<ul style="list-style-type: none"> GIGW 2018 and Cyber Security Audit at International Centre for Information Systems and Audit, Noida for CAG Auditors Cyber Security Requirements and Assessment Methodologies for Indian Air Force Security Assessment Framework for CISOs at Indian Railways Security Awareness programmes at UIDAI for CMVP, Network Security and Digital Forensics End Point Security for CISO under MeitY's Capacity Building Programme.
ERTL-East	<ul style="list-style-type: none"> Various knowledge-based and skill oriented training programmes for industries, laboratories, students & individuals in different areas of technology, such as, Industrial Automation, Test & Measurement, Measurement Uncertainties, Calibration Techniques, and Quality Assurance & Management Standards (ISO 9001:2015, Information Security Management System (ISO 27001:2013) Number of training courses on Laboratory Quality Management Standard ISO/IEC 17025:2017 and NABL requirements. Project based training programmes for engineering college students on Industrial automation (PLC).

Lab name	Training offered
	<ul style="list-style-type: none"> Quality Management System certification as per ISO/ IEC 9001:2015 standard. Served twelve industries in the Eastern region which includes Government organisations (ITR, PXE, CDAC etc.) and Private organizations. Information Security Management System certification as per ISO/ IEC 27001:2013 standard. Served nine industries in the Eastern region which includes Government organisations (BHEL different units, MSTC, etc.) and Private organizations. `S' Mark Certification for Product certification for Safety marking as per different IEC standards. Eight products have been certified. Conducted factory inspection on behalf of Aenor, Spain. Two industries have been served. Website Accessibility and Quality Management System inline with GIGW guidelines in Guwahati and Web Application Security requirements and secure coding in Agartala (North eastern states) as a part of capability build up under STQC MeitY's 100 days Action plan
CFR-Chennai	<ul style="list-style-type: none"> CFR, Chennai, has conducted the 104th "Certified Reliability Professional (CRP)", a National level training program in which professionals and practicing engineers from India and abroad have been trained and certified as Reliability Professionals. Over 2200 professionals have been trained so far. A specialised two day training programme on "Design Reliability Engineering" was conducted for 20 engineers from HCL, Chennai.

9.6.10 Activities in North-East Region (NER)

ETDC, Guwahati and ETDC, Agartala are the two laboratories established by STQC Directorate in North East region. These laboratories have been extending the following services to eight states in the NE region:

- Test & Calibration services to the industries, technology users & Service providers.
- Testing of e-Governance software as well as State portals/ websites etc.
- Audit of IT Infrastructure / third party auditors for the e-Governance projects like State Data Centres (SDC)/ SSDG/ e-District/ SWAN etc.
- Training services in the field of Electronics & Information Technology / Quality & Reliability

9.6.11 Initiatives in Test & Calibration services

Test & Calibration services of ETDC Guwahati & ETDC Agartala are extended towards improvement of quality of the products and services from industries. The services are received by most of the MSME industries covering the industrial sectors like – Oil & Natural Gas, Oil Refineries, Exploration units, Railways, Indian Air Force, Power - Generation, Transmission & Distribution, Paper, Cement & Building material, Food & Beverages, Cosmetics, Cable & Conductors, Fertilizer, Plywood, Carbon Products, Steel, and Service sectors like – Aviation, Engineering & Construction, Telecommunication, Automobile, Service & Maintenance units, R&D and Test Labs, Hospitals, Pharmaceuticals & Pathological Laboratories etc. About 1500 calibration jobs being executed.

9.6.12 NABL Accreditation & Inter-Laboratory Comparison (ILC)

Calibration services of ETDC, Guwahati are accredited by the National Accreditation Board for Testing and Calibration Laboratories (NABL) in conformance with ISO/IEC 17025 in the fields of

Electro-Technical (AC/DC Voltage, Current, Power & Energy, Frequency, Time, Resistance, Inductance & Capacitance), Thermal (Temperature), Mechanical (Acoustics, Pressure, Mass, Dimension & Volume) & Optical (Optical- Power, Wavelength & Stability) parameters. The labs have also participated in Inter Laboratory Comparisons programme organized from time to time.

9.6.13 Initiatives in IT Test & Assessment Services

Initiatives have been taken towards facilitating services in the field of Testing or Assessment of Software Applications, Websites, Web Applications, IT Infrastructure under various e-Governance projects like – Website Quality, e-District, SSDG, State portals, e-Forms, SDC, SWAN etc. being implemented in the states of North East region. More than 500 websites from Govt., PSUs, Research Labs, Academic Institutions, Universities have been tested as per Guidelines for Indian Government Websites.

9.6.14 Initiatives in Training Services in the fields of Electronics & IT / Quality & Reliability

Training cum Workshop has been organized on Website Quality Certification by ETDC, Guwahati for the North-East region wherein sixteen senior and middle rank management executives participated from various organization. Five short-term training courses in the fields of Information Technology have also been organised by ETDC, Agartala at Agartala and about 100 local participants attended the program.

9.7 National Institute of Electronics and Information Technology (NIELIT)

9.7.1 Introduction

National Institute of Electronics and Information Technology (NIELIT), is an autonomous scientific society under the administrative control of Ministry of Electronics and Information Technology (MeitY),

Government of India. NIELIT is actively engaged in capacity building and skill development in the areas of information technology (IT); electronics; communication technologies; hardware; cyber law; cyber security; IPR; GIS; cloud computing; ESDM; e-waste; IoT; e-governance and related verticals.

It offers courses in the formal sector in association with state universities/technical board such as ME/ M.Tech, BE/B.Tech, MCA, BCA programmes, PG Diploma courses, Aurangabad centre is also facilitating to conduct PhD program in the area of electronics.

Courses in the non formal sector in IT, hardware, animation & multimedia and bio-informatics under four levels, namely NIELIT IT 'O' level; NIELIT IT 'A' level; NIELIT IT 'B' level; NIELIT IT 'C' level; NIELIT CHM 'O' & 'A' level, NIELIT MAT 'O' level and NIELIT BI 'O' & 'A' level (b) Short term courses in niche areas; and (c) IT literacy programmes for the proliferation of digital literacy in the country. Besides specialized programmes in e-governance targeted towards empowering the employees of the state governments. In addition, NIELIT has also created expertise for the roll out of customized skill development programmes, as per specific needs of public and private sector firms.

NIELIT is also one of the national examination bodies which accredits institutes/ organizations for the conduct of Electronics & IT courses in the non-formal sector. NIELIT is well represented in the country and has PAN India presence through a network of 43 own centres and a network of about 900+ accredited training partners and about 10,000+ digital literacy facilitation centres.

NIELIT is engaged in Formal & Non-Formal education in the area of IECT besides development of industry-oriented quality education and training programmes in the state-of-the-art areas of IT, electronics, communication technologies, hardware, cyber law, cyber security, information

security, cloud computing, ESDM, e-governance and related verticals and short-term courses (NSQF aligned).

NIELIT qualifications are widely accepted at both national as well as international level. Owing to the quality, some of the NIELIT digital literacy courses are linked with both promotion & recruitment by number of State Governments viz; Arunachal Pradesh, Bihar, Chandigarh, Daman & Diu, Gujarat, Rajasthan, Sikkim, Uttar Pradesh and a few Government Departments viz; DGE&T (for trainees of ITIs/ITCs under craftsmen training scheme (CTS), UPPCL, O/o the CGA (JAO exam) for recruitment / in-service promotion/increment purposes.

NIELIT is amongst the front-runners that have aligned 75 Skill oriented courses with National Skills Qualifications Framework (NSQF) at different levels ranging from level 2 to 8. {NSQF is a competency-based quality assurance framework that organizes qualifications in terms of aptitude, knowledge, skills and learning outcomes; whether they are obtained through formal, non-formal or informal learning.}

Since inception, NIELIT has trained more than 55 lakh candidates. Examinations of digital literacy programmes are conducted in the online mode and digitally signed e-certificates are issued to successful candidates. About 15,48,913 digitally signed e-certificates have been kept in Digi Locker of the students and NIELIT is among the foremost educational institute in the country to institutionalize the mechanism i.e., linking of e-Certificates with Digital Locker.

Taking into account, advancement in IT and Electronics and emergence of disruptive technologies, NIELIT has been making efforts to update its repertoire of courses in upcoming technologies such as Artificial Intelligence, IoT, Big Data, Cloud Computing, Robotics and 3D Printing. In this regard, prominent NIELIT Centres such

as Aurangabad, Calicut, Kolkata etc. are in the process of being identified as Technology Resource Centres to offer blended learning programmes under the Future Skills prime initiative which is being jointly conceived by MeitY and NASSCOM. Up-skilling/ re-skilling eco-system in emerging and futuristic technologies would facilitate continuous enhancement of skills as well as knowledge of IT professionals in line with their aspirations and aptitude. Institutionalization of blended learning mechanism through Technology Resource Centres and affiliated training partners using hub-n-spoke model would widen reach and also ensure deeper penetration in the country. NIELIT is expected to render a pivotal role in the re-skilling/ up-skilling eco-system as well.

9.7.2 R&D, Innovation & Design

Indigenous colour doppler ultrasound scanner with PNDT compliance

The project is being implemented by NIELIT Calicut with financial support of MeitY at an outlay of Rs. 2.44 Cr over a period of three years, with an objective to design and development of indigenous colour doppler ultrasound scanner prototype with PNDT compliance.

A significant feature of the machine is the automatic sex determination monitoring to prevent rampant female foeticide in India. "The scanning details of the pregnant woman should automatically come filled in the PNDT form. Along with this, the biometric

details will be stored on the server kept at union Ministry of Health and Family Affairs in New Delhi. Thus, scanning at each stage is closely monitored leaving no room for abortion.

Setting up state of art digital forensic data centre to provide forensic services including remote forensics live acquisition and analysis of digital evidence, virtual training services to NE States

NIELIT Kohima, NIELIT Imphal and NIELIT Aizawl are jointly implementing the project with the financial support of MeitY of Rs. 4.01 Cr for a duration of 24 months, with following objectives:

- To set up digital forensic data centre with essential digital forensic tools and to offer forensic services by sharing the resources in the facility with virtual technology concept for North Eastern States. The digital forensic data centre is proposed to act as a repository of digital forensics tools for NE States and the services will be offered in cloud environment;
- Creating web based virtual environment laboratory with training content covering latest trends in cybercrimes, seizure/ acquisition & analysis of digital evidence, building case scenarios with advanced forensics techniques to enable LEA officials to gain hands-on forensics investigative skills in various areas like disk forensics, mobile forensics, network forensics, social media etc. through the virtual mechanism;

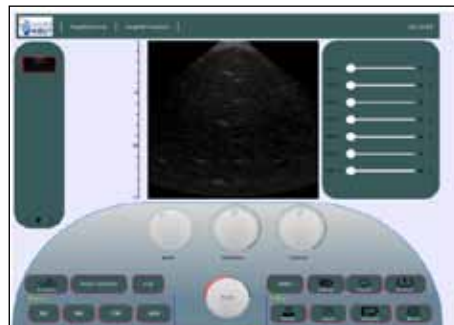

- Based on the need expressed by law enforcement development and integration of web related evidence acquisition tool including automated screen capturing while acquiring web related evidence like media files and documents with forensically sound methods.

9.7.3 Capacity Building Projects

“NIELIT-CII Centre of Excellence for Skills (NICCS)” at NIELIT Aurangabad

The project is being implemented by NIELIT Aurangabad with financial support of MeitY at an outlay of Rs. 1.08 Cr, over a period of 1 year with an objective to utilize cutting edge technology to improve learning outcomes and satisfy industry needs and enhance the employability of the youth of the country.

The CoE will host technologies like Augmented Reality (AR), Virtual Reality (VR), 3D models, RFID, Interactive video wall and Learning platforms to deliver vocational training courses in industry technology.

Empowerment of SC/ ST Youth & Women on Enhancement of Livelihood activities using IT & Tool and PMU for IT for Masses

The project is being implemented by NIELIT Kolkata (in 2 selected districts of West Bengal i.e. Darjeeling and Alipurduar) with financial support of MeitY of Rs. 1.78 Cr and a PMU for IT for masses with budget outlay of Rs. 44.78 lakh over a period of 2 years, with an objective to:

- Empowerment of SC/ ST & Women on functional IT for enhancement of day-to-day livelihood activities and scope of employment generation/ entrepreneurship development;
- To develop 800 IT skilled resource members from SC/ ST & Women candidates through the developed infrastructure under capacity building programme;

- The household women are involved with various handloom products weaving during their free time as livelihood activities. Our role is to enhance the traditional livelihood activities using IT & Tools for new design creation and design printout for easy deployment process which will minimize the process time with modern design creation, increase the productivity and income;
- For handicrafts products, the concept will help and benefit the carpenter and the youth directly for product design creation/ deployment maintaining state-of-art. Darjeeling and Alipurduar districts are heritage for wood furniture products;
- This skill-oriented course on the assembly and installation procedure of solar panels and LED bulb manufacturing for day-to-day uses and prime focus now a days for entrepreneurship development.

Training of visually impaired persons in Manipur on Course on Computer Concepts (CCC) of NIELIT

The project is being implemented by NIELIT Imphal with financial support of MeitY of Rs. 30.21 lakh over a period of 2 years 6 months with an objective to train 200 blind candidates of Manipur State on Course on Computer Concepts (CCC) with 200 Hrs. duration (4-weeks/ 1-month) covering NIELIT’s CCC syllabus with soft skills, as a residential training programme. The training would be implemented by using Indian text to speech software titled “Shruti Drishti” with braille refreshable keyboard to train blind students.

Skill development training of unemployed SC & ST youths of Tripura towards enabling entrepreneurship & sustainable development

The project is being implemented by NIELIT Agartala with financial support of MeitY at an

outlay of Rs. 1.32 crore with SC & ST component of Rs. 65.79 lakh each, over a period of 2 years. The objective is to enable entrepreneurship & sustainable development among SC & ST youths of Tripura by providing skill development training to 1,940 unemployed SC & ST candidates of Tripura in (i) Graphic Designing, Data Entry and Office Automation, (ii) Repair & Maintenance of ECG and ICCU Equipment, (iii) Telecom Technician-PC Hardware and Networking, (iv) Repair & Maintenance of Power Supply, (v) Inverter & UPS and (vi) Installation of Repair of Consumer Electronics.

Setting up of medical electronics laboratory

The project is being implemented by NIELIT Guwahati at its Silchar extension centre with financial support of MeitY at an outlay of Rs. 1.62 Cr (MeitY contribution of Rs. 1.02 Cr and NIELIT contribution of Rs. 59.73 lakh) over a period of three years. The objective is to set up medical electronics R&D laboratory at Silchar extension centre for undertaking repair and maintenance of medical electronics equipment of various hospitals in Assam, so as to solve the major problems faced by the hospitals and patients due to non-operable defective hospital equipment.

Creating skill development facilities in deprived areas through strengthening NIELIT

A project on “Development of North-Eastern Region by enhancing the Training/Education capacity in the Information, Technology (ICT) Area” is being implemented with the objective of upgrading the six existing Centre of the NIELIT in the North-Eastern Region at Guwahati, Imphal, Shillong, Itanagar, Gangtok and Aizawl; and setting up of ten new extension centres and upgrading two extension Centres (Tezpur in Assam and Chuchuyimlang in Nagaland).

All the eighteen (18) centres/extension centres are operational as on date. Ten extension centres are imparting training from built-up space at Silchar, Dibrugarh, Jorhat and Kokrajhar in Assam; Pasighat & Tezu in Arunachal Pradesh; Senapati & Churachandpur in Manipur; Tura in Meghalaya and Lunglei in Mizoram.

About 50,000 students have been trained so far under the project. Possession of land for construction of permanent campuses has been obtained at 12 locations (out of 18) in Pasighat, Kokrajhar, Jorhat, Tezpur, Dibrugarh, Imphal, Senapati, Churachandpur, Aizawl, Lunglei, Gangtok, and Chuchuyimlang. Three central PSUs have been appointed as Project Management Consultants (PMCs) for construction of permanent NIELIT centres & extension centres. Construction activities are in progress at 12 locations i.e. Imphal, Gangtok, Aizawl, Jorhat, Tezpur, Dibrugarh, Kokrajhar, Chuchuyimlang, Pasighat, Senapati, Churachandpur and Lunglei.

NIELIT is presently offering training courses from 21 locations in all eight (8) NE States covering three additional locations at Majuli, Agartala and Kohima under other funded projects by the MeitY.

NIELIT has started activities from permanent campuses at Kohima, Ropar, Patna, Agartala, Ajmer and Kolkata after completion of construction activities.

In addition, NIELIT Centre at Haridwar and extension centre at Mandi (Himachal Pradesh) under NIELIT Shimla have been made operational. NIELIT centres at Buxar & Muzaffarpur (Bihar), have been approved by MeitY for permanent campuses and work order for construction work has been awarded to CPWD. Almora (Uttarakhand), Ayodhya (UP), Dimapur (Nagaland), Bhubaneswar (Odisha) Kargil (Ladakh), Goa and Jalandhar (Punjab) are under establishment.

9.7.4 Skill development in ESDM Sector:

‘Scheme for financial assistance to select States/UTs for skill development in Electronics System Design and Manufacturing (ESDM) sector’

The employment in the electronics industry is estimated to grow phenomenally. Hence to facilitate skill development in ESDM sector focusing on students/unemployed youth at 9-10th standard onwards, ITI, diploma, non-engineering graduates, engineering graduates (in level 5) etc. to increase their employability to work in ‘Manufacturing’ and ‘service support’ functions, a ‘Scheme for financial assistance to select States/UTs for skill development in Electronics System Design and Manufacturing (ESDM) sector’ was approved by DeitY in November, 2013. 90,000 persons are to be supported under the scheme in the following States viz. Andhra Pradesh, Telangana, Jammu & Kashmir, Karnataka, Punjab, Uttarakhand (for 2 levels only) and Uttar Pradesh in 5 levels of vocational skill development courses. The outlay of the scheme is Rs. 113.77 crore with Grant-in-Aid of Rs. 100 crore (approx.). The scheme duration has been extended upto 31.03.2020.

Scheme for ‘skill development in ESDM for Digital India’

Under the aegis of ‘Digital India’ programme launched by Hon’ble Prime Minister, the department has approved a scheme for “Skill Development in ESDM for Digital India” on 09.12.2014 to cover all the States/UTs of the country in order to facilitate creation of an eco-system for development of ESDM sector in the entire country for facilitating skill development for 3,28,000 persons in ESDM sector at an outlay of Rs. 411 crore. This is in continuation of the above mentioned ‘Scheme for Financial Assistance to select States/UTs for skill development in Electronics System Design and Manufacturing (ESDM) sector’ approved

earlier. Both the Schemes are to be implemented concurrently.

These schemes provide for 75 % of training fee as assistance for training courses identified by Electronics Sector Skills Council (ESSC), Telecom Sector Skills Council (TSSC) and NIELIT. The scheme also provides for 100% fee reimbursement to 40% of the seats which would be reserved for the candidates belonging to SC/ST/Economically weaker sections. Further, Registration-cum-Certification fee per candidate (for the first attempt only) would also be reimbursed to assessing/certifying agencies.

Government has notified the revised guidelines in Nov-2018. The revised guideline has 60% seat allocation based on industry demand. The key implementing agencies (viz. ESSCI, NIELIT, TSSC) shall submit a demand-based proposal which would include the details of tie-ups with industry/ firms where the candidates are likely to be placed. These proposals may also indicate the category under which training is proposed, i.e., ‘Place & Train’ or ‘Train & Place’ and preference for allocation would take into account reasonable assurances of employability. The remaining 40% seats would be allocated only to training partners based on their past credibility in promoting employability of its candidates.

NIELIT is implementing both these schemes on behalf of MeitY and an ESDM-Programme Management Unit (ESDM-PMU) is set-up by MeitY under administrative control of NIELIT to monitor the project at ground level.

Under these ESDM Schemes skill development training in electronic sector is provided to students and unemployed youths through training partners which are registered under the three key implementing agencies viz. Electronics Sector Skills Council, Telecom Sector Skills Council and NIELIT.

As on 31st December 2019, under both the above Schemes, 3.68 lakh candidates have been enrolled out of which around 3.32 lakh candidates have been trained in various States/UTs, out of which around 2.12 lakh candidates have been certified. The Scheme Duration has been extended upto 31.03.2020

9.7.5 Training of Government officials on e-Waste management under 'Digital India'

MeitY had initiated "Awareness programme on environmental hazards of electronic waste through Digital India Initiative" and provided responsibility to NIELIT for conducting the awareness programme on e-Waste management for the Government officials in different States through 1/3/5 days training programme so that the Government officials were made aware about e-Waste, its hazards and management.

Phase-I (Completed): In Phase-I of the project, NIELIT imparted training to Government officials of ten (10) States through 1/3/5 day training programme. The target of training 2,000 Government officials was exceeded by NIELIT and 2,273 Government officials were trained covering ten States, namely, Assam, Bihar, Goa, Jharkhand, Madhya Pradesh, Manipur, Odisha, Uttar Pradesh, West Bengal, and Puducherry.

Phase- II (Undergoing): Based on the success of the phase-I of the project, the phase-II of the project has been awarded to NIELIT Kolkata with the target to impart training to 3,200 Government officials in 19 States/UTs which were not covered earlier under Phase-I. The States covered under Phase-II are – Andhra Pradesh, Arunachal Pradesh, Chhattisgarh, Delhi, Gujarat, Haryana/ Punjab, Himachal Pradesh, Jammu & Kashmir (currently J&K and Leh), Karnataka, Kerala, Maharashtra, Meghalaya, Mizoram, Nagaland, Rajasthan, Sikkim, Tamil Nadu, Tripura, Uttarakhand. Phase-II of the above awareness programme is in progress. The target was later increased to 3,500.

As an outcome of the training program, the Government officials in identified States/ UTs are effectively dealing with the management and disposal of e-Waste in their department/ division, resulting in freeing up of valuable office space and better revenues, through a proper process which is both, environment friendly as well as in line with the applicable laws of the land. The project has been successfully completed with the training of 3,500 Government officials.

9.7.6 Synergy through Collaborations & MoUs

A MoU has been signed between NIELIT and Institute for Information Industry (III) in India Taiwan Industrial Collaboration Summit held on 17th October 2019 in respect of "Joint Training Program in the field of Electronics & IT for a period of five years". Five year training programmes in next 5 years is to be conducted jointly by NIELIT and Institute for Information Industry (III) (a partner institution from Taiwan side) to expand and enhance cooperation in training and skill development in the field of Electronics and Information Technology through the exchange of institutional experience, training and skill development between India and Taiwan. Initially in first year, group of 39 Participants (35 from Industry, 3 from NIELIT and 1 from MeitY) would attend theory classes in India and same batch to travel to Taiwan for hands-on training for 11 days.

9.7.7 Embedded and IoT Ventures

Remote intelligent monitoring system

This is a smart city prototype project using emerging technologies like IoT and Artificial Intelligence. One of the key attractions in this project was the long range sub1GHz connectivity technology LoRa. The objective was to design a trouble free and systematic vehicle monitoring system, light automation and water level monitoring system. The system prototype was tested in NIELIT campus. The connectivity was also tested between two buildings separated 1 KM apart.

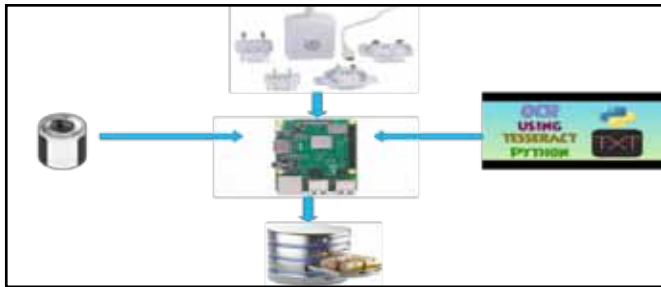

The project has three units, first the vehicle detection unit captures the vehicle details using AI and maintains the data in a server. The second unit water level monitoring system, is used to monitor the water level of overhead tanks. The distance between tank and the monitoring station can be up to 10 Km in line of sight. The third phase integrates a multi controllable light unit which can be operated with traditional switches, with the help of mobile phone App or from internet connected computers. The status of the light and the previous history is recorded in the server.

This multi-dimensional prototype has huge demand in near future in different areas like smart city, smart water monitoring, smart environment monitoring, industrial IoT and Industrial 4.0 based applications.

Smart shoe for women safety

Now a days, women and children safety are a prime issue in our society and unfortunate incidents are taking place. Nowadays mobile phone is used by almost everyone to keep in touch with family and friends. "Smart Shoe for Women Safety", focuses on a security system that is designed solely to serve the purpose of providing security and safety to women so that they never feel helpless while

facing social challenges.



This proposed model uses a microcontroller with sensor placed inside the women shoe and an Android application specially designed for safety of women. This App can be activated by a single click of button in the App, whenever need arises. All that a women needs to do is that whenever she is in danger she need to just remove the shoe and app identifies the location of place through GPS and sends a message of that location to the saved contacts and also calls all the saved contacts to help the one in dangerous situations. The unique feature of this application is that user can modify and save the contact number to be called and messaged every five minutes for three times. And also, rechargeable battery is provided for controller, in order to provide power supply.

IoT based smart summoning system

Road accidents are increasing day by day. The main reason behind this problem is violation of traffic rules. This smart system forces the user to be safe. The system will transform the vehicle to a smart one by connecting the vehicle with the appropriate department thereby they can access the data about rule violation details.

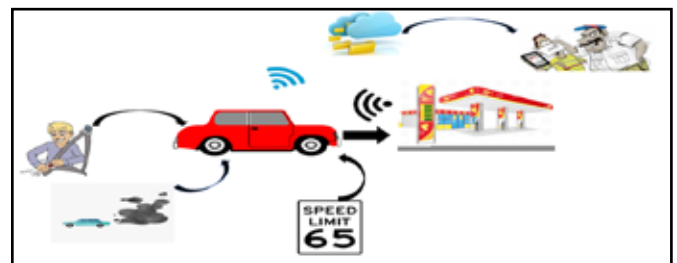

The system involves Embedded and IoT design. The system uses sensors to read speed, pollution index and seat belt status. All these details are compared with the permitted level and are recorded. When the vehicle enters the petrol pumps, the whole data is automatically pushed to the appropriate department server using a common Wi-Fi gateway on all petrol bunks. All the data will be continuously saved in the cloud. Summons can be given on the basis of the data. Through NFC tag attached on number plate, the driver can access all the details about violation of vehicle if required. The system uses NODE MCU as the hardware tool and ARDUINO as software tool.

Biometric attendance & entry control with automation

The system adopts the usage of biometric fingerprint reader for students to mark attendance for the classes attended. In the system a microcontroller-based system provides biometric authentication and recording attendance of students in a database stored in local server. A local area network web platform integrates student attendance record information and message input to wireless digital display. The project integrates all these features along with intelligent automation of lights into a single platform.

The biometric sensor is used to provide restricted entry into lab by granting access only for authenticated individuals. It ensures lab security by monitoring the individuals entering and leaving the lab. The total count inside the lab is maintained and this allows intelligent automation features including turning off lights and fan when no one is present inside the lab. Other features include a wireless digital display controlled from local server webpage to notify important messages in the lab.

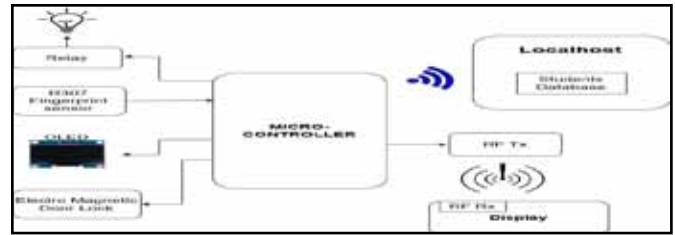

Virtual Personal Assistant

This project implements a Virtual Personal Assistant (VPA) to control electronic appliances (such as lights and fans) and to monitor certain parameters like temperature, humidity, air quality, water level of overhead tank through voice commands. It not only controls the devices but also allow us to know the current status of those devices from anywhere at any time. This voice-based system assists users with sight and mobility limitations and elderly people.

9.7.8 Some Notable Achievements

- **Workshop on machine learning:** As a part of internal capacity building, NIELIT Delhi Centre organized a 3 Day workshop on ‘Machine Learning for Data Science & Analytics’ from 23rd to 25th May 2019 at NIELIT HQ, New Delhi. Participants were given an introduction of concepts like regression, clustering, classification techniques in machine learning.
- **NIELIT student’s placements:** On completion of free employability training under the TCS Affirmative Action Program (TAAP) organized by NIELIT Kolkata for its 22 students from SC/ST and economically backward classes from Minority and other social groups, 9 candidates were offered jobs under the scheme.
- **Symposium on qualitative research:** A one-day “Symposium on Qualitative Research” was organized on 24th April, 2019 by NIELIT Kolkata in order to provide a platform for identifying research needs and understanding methods and techniques that are used for conduction of research.

- **Android training for State Govt. officials:** A one-month training on 'Android App Development and Networking' was conducted in April 2019 by NIELIT Kohima for the officials of Department of Information Technology & Communication, Govt. of Nagaland.
- **Cybercrime for law enforcement agencies:** Equipping legal fraternity and law enforcement agencies to meet the rising challenges of cybercrimes and related issues, an awareness programme titled 'Cyber Crimes, Cyber Laws in India and Electronic Evidence' for lawyers, prosecutors and law enforcement agencies was conducted by NIELIT Kohima on May 24, 2019.
- **Livelihood enhancement for underprivileged youth:** Improving employability and livelihood opportunities of the underprivileged youth of eastern Nagaland, NIELIT Kohima is conducting a month-long residential training on "Repair & Maintenance of Power supply, Inverter and UPS" under sponsorship of Department of Underdeveloped Areas (DUDA), Govt. of Nagaland.
- **Cyber Shiksha for women:** NIELIT Patna Centre is providing training on Cyber Security and Cyber Forensics to women candidates under the project Cyber Shiksha launched by Data Security Council of India sponsored by Microsoft. On completion of the 1st batch training, a Certificate Distribution Ceremony was held at the Centre on 30th April 2019 in the presence of Dr. Jaideep Kumar Mishra, Director General, NIELIT and Joint Secretary, MeitY.
- **Skilling for Bihar Gram Yojna Society-PES, e-Panchayat, GPMS:** Three days training program on "PES, e-Panchayat, GPMS and other State specific Apps and WAPs" for the Data Entry Operators and Accountants of Bihar Gram Swaraj Yojna society (BGSYS), Deptt. of Panchayati Raj. Govt. of Bihar was held in 8 districts of Bihar i.e. in Samastipur, Madhubani, Patna, Nalanda, Bhojpur, Rohtas, Gaya and Aurangabad.
- **Information security workshop for district officials:** NIELIT Patna has conducted e-Governance and Information Security workshop for district officials of Nawada and Gaya district of Bihar. 150 district officials from various districts attended the Workshop.
- **Information security awareness:** A half day workshop on Information Security Awareness was organized at Hindi Higher Sec. School by NIELIT Agartala in association with CDAC, Agartala on 26th April 2018 under Information Security Education and Awareness (ISEA) project phase-II. Nearly 80 IT Teachers and Principals of different CBSE schools of Tripura attended the workshop.
- **Industrial training - Python, Linux, Apache, MySQL:** Industrial training of 150 engineering students from different colleges is being taken up in June 2019 at NIELIT Agartala campus in various areas including Python, Linux, Apache, MySQL, PHP, JAVA Routing & Switching, CAD using CREO, Solar Power Installation and Web designing.
- **Electronic Board Design and Bring up:** A two days hands on workshop on 'Electronic Board Design and Bring up' was conducted on 27th and 28th April 2019 by NIELIT Calicut in association with IEEE Malabar subsection and Kerala chapter of IEEE Computer Society for around 50 participants from industry and academia.

9.7.9 Training Summary

NIELIT plays an important role of skilling people in the area of Information, Electronics and Communication Technology (IECT). Number of

candidates skilled/ trained in various courses during April to September 2019 are as follows:

S. No.	Course Category	Number of Candidates Trained/Skilled
1	Formal Courses (M.Tech/BCA /MCA/3 Years Diploma etc.)	2,251
2	Non-Formal Courses (O/A) Level in IT/Hardware/ Multimedia etc. of one year duration or more)	3,255
3	Short Term Courses (Including all short-term courses less than one year duration, excluding Digital Literacy Courses)	9,765
4	Digital Literacy Courses	3,41,185
	Total	3.56 Lakh

9.8 Software Technology Parks of India (STPI)

Introduction

Software Technology Parks of India was set up in 1991 as an autonomous society under the Ministry of Electronics & IT, Government of India. STPI's main objective has been the promotion of software exports from the country. STPI acts as 'single-window' in providing services to the software exporters. The services rendered by STPI for the software exporting community have been statutory services, data communications services, incubation facilities, training and value-added services. STPI has played a key developmental role in the promotion of software exports with a special focus on SMEs and startup units.

STPI has been implementing the Software Technology Park (STP) scheme and the Electronics Hardware Technology Park (EHTP) scheme for the promotion of IT/ITES/ESDM industry. The phenomenal success of the IT/ITES industry has been possible, inter-alia, due to pivotal role played by the STP Scheme. STP Scheme is a unique

scheme, designed to promote the software industry and growth of Start-Ups and SMEs without any locational constraints. As on 31st December 2019, 5124 units are registered under STP scheme and 70 units are registered under EHTP scheme.

During the FY 2019-20 (till 31st December 2019), IT/ITES export from STPI registered units are Rs.3,06,766 crore (tentative) and Electronics Hardware export of Rs.2,594 crore (tentative) under EHTP scheme.

STPI Centres

To provide statutory and incubation services to industry, major thrust was given on the establishment of new centres as well as revamping of existing centres. As on 31st December 2019, a total of 60 STPI centres/ Sub-centres are operational across the country, out of which 52 centres are in Tier II and Tier III cities.

STPI is working closely with the respective State Governments/local authorities for creation of more space, equipped with state-of-the-art infrastructure facilities, for development of the software industry and increasing exports.

Services:

The main services rendered by STPI for the software exporting community are as below:

- Statutory Services**
 STPI provides Single Window Clearance to Software exporters under the STP Scheme. STP Scheme provides these units with various benefits making it a phenomenal success.
- Incubation Facilities**
 Business and technology incubation stimulate the growth of startups. STPI is offering ultra-modern office facilities to small units and entrepreneurs. Plug-n-Play facilities for startups enable short gestation period. This has encouraged many entrepreneurs to start

their own operations and grow in a competitive environment.

- **Datacom Services**

One of the STPI's remarkable contributions to the software-exporting sector is provision of High-Speed Data Communication (HSDC) services. STPI has designed and developed state-of-the-art HSDC network called SoftNET for software exporters. Local access to international gateways is provided through point-to-point and point-to-multipoint microwave radios which has overcome the last mile problem and enabled STPI to maintain an uptime more than 99%.

- **Consultancy Services**

STPI provides consultancy and Project Management Services and turnkey solution to various national and International organisations in the areas of Communication Networks, Network Operation Centres, Network Management Systems, Computerization, e-Governance networks etc. The technology capability coupled with process strengths has enabled STPI to secure a number of projects from time to time.

India BPO Promotion Scheme/North East BPO Promotion Scheme

STPI is the nodal agency for implementation of India BPO Promotion Scheme (IBPS) and North East BPO Promotion scheme (NEBPS) under Digital India Initiative. The objectives of the schemes are to create around 1.5 lakhs job opportunities for the local youths of smaller towns and also to attract investments in the respective regions for all round development. These schemes will help in creating right ecosystem required for the growth of smaller towns and bring prosperity to those locations.

The schemes provide financial support along with several special incentives like encouraging employment to women and specially enabled

persons, setting up operations at other than State Capitals, promoting local entrepreneurs etc. up to Rs. 1 lakh/ seat in the form of Viability Gap Funding (VGF). The selection of eligible companies to set up BPO/ITES operations under IBPS and NEBPS is through online bidding process. Around 48,300 BPO/ITES seats have been provisioned across State(s)/UT(s) under IBPS and 5,000 seats for BPO/ITES Operations in North East Region under NEBPS.

Under IBPS, as on 31st December 2019, 190 companies have been declared successful to setup 276 BPO/ITES units for 51,297 seats distributed around 107 locations covering 22 States/ UTs. Out of these, 246 units for 47,584 seats have started operation and so far, reported employment of 35,205 persons. Total 50 claims for Viability Gap Funding (VGF) of amount Rs. 11.3 crore have already been disbursed/approved under IBPS.

Under NEBPS, as on 31st December 2019, 2,001 seats have been allocated to 20 successful bidders to setup 29 BPO/ITES units covering 6 States of NER (Assam, Nagaland, Meghalaya, Manipur, Tripura and Arunachal Pradesh). Out of these, 14 units for 1,275 seats have started operation and so far, reported employment of 659 persons. One claim for Viability Gap Funding (VGF) has been disbursed under NEBPS.

Electropreneur Park

Electronic System Design and Manufacturing (ESDM) is one of the fastest growing sectors of the Indian economy. In order to support the new entrepreneurs of this industry, STPI in association with University of Delhi and Indian Electronics and Semiconductor Association (IESA) has set up an Electropreneur Park in the Delhi University campus.

The initiative will support 50 startups in ESDM space and aims to create at least 5 global companies over a period of five years. The park will focus on local IP creation and indigenous product

development resulting in increased domestic value addition and will witness a unique integration of academia, industry, Government and other incubative supportive elements. The initiative is first of its kind in the industry and it is likely to set a role model, which may go a long way in the annals of incubation centre.

Till 31st December 2019, The Electropreneur Park has supported 33 startups to avail the incubation facilities at the park. As an outcome, 20 new products and 15 working prototypes have been developed, 18 Patents filed, six startups have received external funding support to the tune of Rs. 8 crore, total revenue generated by the startups is Rs. 25 crore and employment for 196 persons have been generated by the startups.

Fab Lab at Bhubaneswar

STPI has set-up its 1st Fab Lab at Bhubaneswar with the support of Electronics & IT Department, Govt. of Odisha and IIIT Bhubaneswar. The STPI FAB Lab Program would offer a vibrant ecosystem for creating a maker culture among the young tech-entrepreneurs, who are keen to develop their innovative technology idea into product prototypes with fine design functionalities.

Centres of Excellence (CoEs)

To ensure India builds leadership in the emerging technologies such as IoT, BlockChain, FinTech, Artificial Intelligence, Augmented & Virtual Reality, Medical Electronics & Healthcare, Gaming & Animation, Machine Learning, Data Science & Analytics, Cyber Security, Chip Designing, ESDM, etc and to build next wave of budding entrepreneurs, CoEs are being setup by STPI in collaborative approach across the country and STPI shall act as single-window facilitation centres to extend requisite lab support, funding & mentoring. The CoEs will have dedicated chief mentors & eminent experts who would also act as brand ambassador of particular CoE. Currently, STPI has taken-up

establishment of 13 domain-specific CoEs spread across Country viz. Bengaluru, Bhubaneswar, Chennai, Mohali, Guwahati, Imphal, Shillong, Lucknow, Gurugram, Patna, Pune and Hyderabad. More such CoEs are in pipeline.

As on 31st December 2019, following is the status in terms of implementation of the CoEs:

Centre of Excellence (CoE) in FinTech at Chennai: MeitY has initiated a CoE in FinTech at STPI, Chennai in collaboration with Govt of Tamil Nadu, IIT Madras, TiE Chennai and various industry partners such as Intellect Design, NPCI, Yes Bank, PayPal, Pontaq Ventures, RBS, Torus Innovations etc, to provide infrastructure, resources, coaching/mentorship, technology support and funding to emerging start-ups in the FinTech sector. Christened 'FinBlue', the CoE would establish ecosystem around FinTech with the latest trends and technologies in the financial services sector through a collaborative approach including NPCI, UIDAI and Partner Banks. FinBlue's purpose is to create holistic ecosystem so as to enable start-ups to experiment their innovative financial products or services within a well-defined space and duration. FinBlue aims to support 58 start-ups over a period of 5 years.

FinBlue has started its operations with the launch of widely-publicised "Pitch Fest" held during the July-September 2019 quarter.

IoT OpenLab - a Centre of Excellence (CoE) for Internet of Things at STPI Bengaluru: IoT OpenLab in partnership with Arrow Electronics at STPI Bengaluru has been initiated to provide academic and business mentoring of the start-ups in the emerging technology area for developing products and/or services around IoT along-with networking opportunities. The IoT OpenLab intends to support & nurture 100 start-ups per year with an overall target to support 500 start-ups over a period of 5 years.

The OpenLab has launched its Open Challenge Programme for invitation & selection of beneficiary start-ups.

Electropreneur Park, an ESDM CoE at Bhubaneswar: Replicating the successful model of Electropreneur Park at New Delhi, establishment of EP-Bhubaneswar, an ESDM CoE with the objective of creating a holistic eco-system to promote ESDM innovation, R&D and create Indian intellectual property in the eastern region of the country has been initiated. EP-Bhubaneswar is being set-up through STPI in collaboration with Government of Odisha, IIIT Bhubaneswar and IESA. It aims to leverage 40 start-ups over a period of 5 years

EP Bhubaneswar has launched its operations in December 2019 and is currently inviting applications from start-ups.

Neuron – “Start-up Punjab Hub @ STPI” (SPHS): A Centre of Excellence in AI/Data Analytics, IoT & AVG is being set-up in collaboration with MeitY, Govt. of Punjab, ISB-Mohali, PTU and industry. Neuron is an initiative, to identify and evaluate promising start-ups in the field of AI/Data Analytics, IoT and AVG that has been hosted in the SPHS Mohali Incubation Facility with a dedicated 500 seats co-working space and dedicated labs for AI/Data Analytics, IoT and AVG. Apart from physical & sector-specific infrastructure, the hub will have the access to domain experts, technocrats, mentorship programmes as well as funding.

Neuron’s “Open Challenge Programme” was initiated open during the “Soft Launch” held on 30th September 2019 in Mohali and applications are currently being screened for onboarding of potential startups.

Autonomous Connected Electric Shared (ACES) Mobility CoE at Pune: The future of automotive is electric, shared, autonomous, and connected. Accordingly, a CoE in “ACES Vehicles” called “Motion” i.e. *Mobility in Action* is being established at Pune in collaboration & partnership which includes

Government of Maharashtra, M/s. Tata Motors, M/s. Kinetic, M/s. Visteon, M/s. MathWorks India, M/s. Intel, College of Engineering Pune (CoEP) and associations like ARAI, SAE-India, TiE-Pune etc. The ACES CoE is being established over 7000 sq. ft. of space (including lab & incubation) at STPI-Pune and targets to benefit 50 domain-specific start-ups over a period of 5 years.

Motion has its Soft Launch conducted in December 2019 during which an Open Challenge Programme has been initiated to invite innovative ideas working in this sector.

MediTech CoE at SGPGI Lucknow: Given the large dependence of India on imports (constituting 65% of India’s medical electronic equipment & consumables) and the fact that demand of medical products & services is going to rise exponentially, a CoE in Medical Electronics & Health Informatics at Lucknow is being set-up to boost start-ups in this field and contribute to “Make-in-India”.

SGPGI Lucknow is a premier medical institute in terms of training, research & health informatics capabilities where the CoE is being set-up. The CoE targets to benefit 20 start-ups per year in 5 years.

Virtual & Augmented Reality CoE (VARCoE) at Bhubaneswar: With an intention to create an ecosystem for carrying out R&D in immersive visualization, give impetus to R&D, Incubation, IP Creation, Product Development, Skill development and Entrepreneurship in AR, VR and allied fields, the VARCoE has been set-up at IIT Bhubaneswar.

VARCoE intends to benefit & support 300 incubatees, researchers & startups over a period of 5 years. VARCoE is operating from 5600 sq.ft space allotted in School of Electrical Sciences & School of Mech. Sciences at IIT Bhubaneswar.

The VARCoE has started operations with first set of projects working on various applications of VR/AR admitted. Currently, pan India Hackathon is

underway inviting applications from entrepreneurs/ start-ups doing innovative work in this area.

Promotion of Small and Medium Entrepreneurs by creating a conducive environment in the field of Information Technology

STPI has been promoting SMEs and their cause by offering incubation services, organising events, sponsoring/co-sponsoring events, participation in events and export promotion efforts. Some of the major events in which STPI participated/sponsored includes:

- INNOG 2019 held from 1st – 4th July 2019 at New Delhi
- INFOCOM Delhi 2019 held on 11th July 2019 at New Delhi
- HYSEA's Innovation Summit held on 01-08-2019 at Hyderabad
- 15th India Innovation Summit 2019 held from 21st- 22nd August 2019 at Bengaluru
- Digital Rajasthan Conclave on 28th August 2019 at Jaipur
- Bengaluru Tech Summit 2019 held during 18th – 20th November 2019 at Bengaluru
- TiE Global Summit 2019 held during 14th -15th November 2019 at New Delhi

9.9 Digital India Corporation (DIC)

9.9.1 Introduction

Digital India Corporation (DIC) has been setup & promoted by Ministry of Electronics and Information Technology (MeitY), Govt. of India as a not for profit (Section 8 of the Companies Act, 2013) Company. The objective of the Company is to bring the benefits of Information & Communication Technologies (ICT) for socio-economic uplift at grass-root level of society. 'Innovation for Digital Inclusion' is its vision.

The Board of the Company is chaired by Hon'ble Minister for Electronics & IT and with other Directors being Hon'ble MoS for MeitY; Secretary, MeitY; AS

& FA, MeitY; MD&CEO, DIC; CEO, MyGov and other eminent members from Industry & Academia.

The application areas are Livelihood Enhancement (Agriculture, Design tools for Artisans & Weavers, ERP for SMEs etc.), Healthcare and Empowerment of Persons with Disabilities (PwDs). In this endeavor it is working with Govt. (User Departments / Ministries), R&D Institutions, Academia, Industry, NGOs & other organisations / industries.

National e-Governance Division (NeGD) is an Independent Business Division (IBD) within DIC to take up Programme Management of the National e-Governance Plan (NeGP) of MeitY. MyGov (An online platform to engage citizens for participatory governance in India) is another IBD within DIC.

The Division focuses on 'Lab to Land' and 'Early Harvest' projects useful for the masses. In addition to its core activities, the Division is implementing 2 major programme: Information Technology Research Academy (ITRA) and Visvesvaraya PhD Scheme in Electronics & IT

9.9.2 Achievements during 2019 – 2020

9.9.2.1 DigiBunai™ - "An Open Source CAD Tool for Weaving"

DigiBunai™ is an open source CAD software for textile designing to optimize the pre-loom process time of designs creation, graphs generation and punching the jacquard cards with the ability to view the complete garment digitally along with various colors, designs & size combinations before weaving.



Dashboard- DigiBunai™ Software

DigiBunai™ helps both Dobby & Jacquard users:

Dobby Module helps the users to create different types of innovative weaves with the provision to generate a weave library. These weaves are required to generate various fabrics of different color combinations.

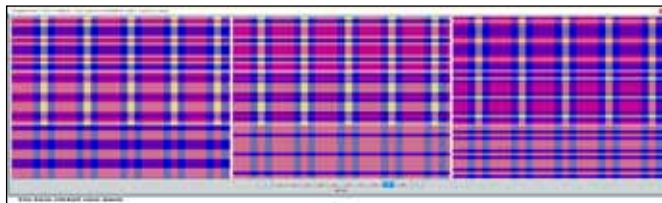

Dobby Fabric-Colorways depict all the

Jacquard Module facilitates creation of jacquard designs (artworks), weave filling into the artwork (shape / color based) and generates different types of graphs (single color, multi-color, split graphs etc.). It supports printing of graphs for punching the jacquard cards and direct punching through Electronic Punching Machine. The garment viewer provides the close to real look of the garment by adjoining all the components with all the possible combinations of repeat patterns.

The software is being enhanced with the advanced features to cater the wider user category as recommended by the Users & Experts:

- Support to Ikat weaving technique.
- Compatible with power loom and electronic jacquard
- Enhancement of software delivery methods
- Web portal for training & support
- Deployment and testing in various weaving clusters and textile institutes.



Digital Fabric depict warp and weft interlacement



Weave Library

User Groups of DigiBunai™ application include Textile Designers, Graph Makers (textile designs), Jacquard Card punching vendors, Master Weavers and Next Generation (Students). More than 150 users are using DigiBunai™ application including 15 Textile Institutions / Training Centers and Community Designers / Weavers. A library of 550 weaves has been created.



Designer using DigiBunai™ in Varanasi

9.9.2.2 Digital Solutions for the Weavers / Designers and Artisans of NE Region (Mizoram)

The project has been undertaken to enhance and customise the ICT applications in the area of Embroidery & Weaving and its field testing in state of Mizoram for the benefits of Artisans & Weavers is going on. The available technologies are being enhanced / customized to suit the local requirements. The technologies that are being customized for Mizo Artisans & Designers are:



Designer using DigiBunai™ in Mizoram

- Chic™ (CAD Tool for Embroidery)
- DigiBunai™ (CAD Tool for Weaving/ Designing)
- So far, more than 100 weavers / designers/ artisans have been trained and another 50 would be trained bringing a total of 150 artisans who would continuously use the application for the benefits of Artisans of Mizoram. 20+ users installed the DigiBunai™ software in 4 intuitions viz. Department of Sericulture, Women Polytechnic Institute, Blitz Institute of Creative Arts (BICA), Mizoram University and community weavers / designers.
- Potential beneficiaries: 20,000+ Weavers/ Designers/ Artisans (as per All India Handloom Census 2019-20) of the state.



Handloom Weaver

9.9.2.3 Rural Women Technology Park at Basani, Varanasi

A Rural Women Technology Park (RWTP) has been setup for Women Empowerment through Skill Enhancement, Entrepreneurship Development and



Designers Attending Training Session

providing Market Linkages using ICT. The objective is to benefit more than 6,000 women through CAD (Computer Aided Design) tool for crafts for digital designs creation, Retail Management, Food Processing and Health Awareness. The progress made during the year is as follow:

Sr. No.	Training Programme	Beneficiaries registered	Total Beneficiaries
1	Chic™ (CAD tool for Crafts)	159	229
2	Retail Management / EDP	108	122
3	Food Processing / Preservation	200	200
4	Health Awareness Programmes	1420	1570
Total		1887	2121

In addition, 455 khaka patterns and 40 finished products have been prepared during the year.

The project is being implemented with the support of Department of Science & Technology (DST) under its Science for Equity, Empowerment & Development (SEED) scheme



Training of Master Trainers



Women artisans receiving training on embroidery designs using Chic™ with hands-on experience



9.9.2.4 ICT Intervention for Development & Livelihood Enhancement through Women Self Help Groups (SHGs) in Majhwa block of Mirzapur (a backward district), U.P.

The main objective of the project is to provide Information & Communication Technology (ICT) based solutions for development, livelihood & knowledge enhancement in Majhwan block of district Mirzapur (a backward district notified by MSME & NABARD). A Resource Centre equipped with the requisite equipments (hardware & software) and infrastructure has been setup to sensitize/familiarize 500 persons on Chic™ (CAD tool for embroidery designing) and khaka making, 800 persons on value addition to fruits & vegetables (food processing / preservation), 800 persons on kitchen gardening / dairy development activities, 200 (about 10% of persons benefitted from Chic™ CAD, food processing, kitchen gardening & dairy development) on Entrepreneurship Development Program (EDP) and market linkages. In addition,

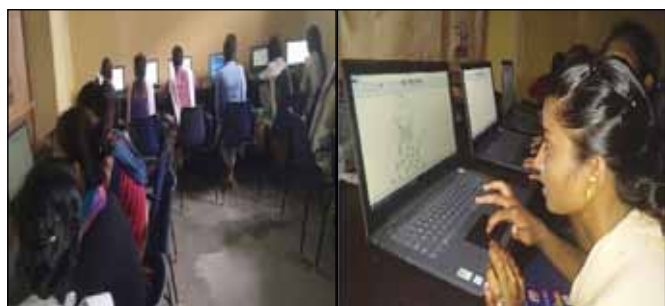

Women / Girls from Majhwa (Mirzapur) receiving training on Embroidery Designs using Chic™ CAD at the Resource Centre setup under the project

2200 persons will be benefitted through health awareness programmes using multimedia content through tablets / mobiles / projector.

9.9.2.5 ICT based capacity building for empowerment in the area of health & livelihood for the women belonging to SC/ST community in Latur district of Maharashtra.

Latur is a predominantly backward district of Marathwada region of Maharashtra. With the failing monsoon a large part of Latur population has been rendered unemployed or underemployed. The lack of livelihood opportunities and poor healthcare facilities, especially for SC/ST women & girls is a major challenge in the district. The project would bring direct benefits of ICT to 2000 SC/ST women and girls in the Latur district of Maharashtra. The objectives of the project include:

- Setting-up an ICT resource center for entrepreneurship development in Latur district of Maharashtra
- Creation of digital tools & techniques to empower women entrepreneurs in the area of E-financing, E-commerce, e-market etc.
- Establishment of Arogya-Sakhi model to provide preventative health awareness.
- Creation of localized digital content and mobile application for health awareness and screening.

The Center would offer mentors for entrepreneurial leadership and resource support for long term

sustainability, domain specific knowledge and linkages for seed-fund capital (to selective beneficiaries) to expand or set up micro enterprise units. It is also expected to provide the affordable preventive health care facilities at the doorstep of the community.

9.9.2.6 Interactive Information Dissemination System (IIDS)

IIDS is a pull & push based system currently being used for delivery of agro-advisories. It is a combination of Smart Phone Application, Interactive Portal and Interactive Voice Response System. There is a mobile interface at front end and web interface at back end. Data is transmitted through voice, text, images and videos from both ends (farmers to experts & back).

IIDS has become a useful tool in enhancing the outreach of Agriculture Universities & Institutions. It enables farmers to interact directly with local Agro-Scientists in their native languages (currently Telugu in AP & Telanagana and Khasi & Garo in Meghalaya). The experts have access to knowledge & farmer database. It enables them to understand the farmers and appreciate their field problems in a better way - Know Your Farmer (KYF).

IIDS has been integrated with push based 'Text & Voice' message services under National Mobile Governance Initiative of MeitY.

IIDS Deployments during the year 2019-20 are as given below:

A. Annapurna Krishi Prasaar Seva (AKPS):

IIDS is deployed as AKPS along with Acharya N G Ranga Agricultural University (ANGRAU) and Prof Jayashankar Telangana State Agricultural University (PJ TSAU) in 22 districts of Andhra Pradesh (AP) & Telangana.

During the year, 16,410 new farmers were registered for the services and a total of 76,161 farmers are

now registered for AKPS services. 2075 queries were received from farmers on Agriculture, Animal Husbandry & Fisheries that have been resolved by KVKs / DAATTCs Scientists / Experts through the toll free number. Need based 68.05 lakhs text & 11.28 lakhs voice messages were sent by Krishi Vigyan Kendras (KVKs) and District Agricultural Advisory and Transfer of Technology Centres (DAATTCs) to their respective farmers registered under the program.

B. Mobile based Agro Advisory System for North-East India (m4agriNEI)

DIC signed an MoU with Govt. of Meghalaya (GoM) for implementation of IIDS with their integrated program for Connecting Farmers to Market viz. 1917iTEAMS. GoM has established a 45 seater Agriculture Response Center (ARC) at Shillong using DIC's IIDS2.0 platform. The existing communication infrastructure of DIC established at its Mumbai office is being used for program implementation. During the year, 4632 new farmers from Meghalaya were registered under the project and with this the total no. of registered farmers has reached 22,068. 498 queries of the farmers were resolved by 1917iTEAMS. During the period 365 requests received from farmers to buy-sell their produce (Buy – 129 and Sell - 236) and 561.52 Ton of farm produce transported in 543 trips as per the requests received from farmers.

IT platform (IIDS 2.0) has been enhanced by adding new features viz. facility to register farmers & buyers on call through Toll Free Number, facility for farmers to book a vehicle for transportation of their produce / crops, to take request and share information on buyer-seller and to provide technical advisories on agriculture, horticulture, livestock and fisheries. The following new logins with specific roles and features have been created in IIDS:

- Member-Secretary 1917iTEAMS
- Program Manager (PM)

- Agri Resource Center (ARC) Coordinator
- Incoming Communication Officer (ICO) – Level 1
- Incoming Communication Officer (ICO) – Level 2
- Business Development Executive (BDE)
- Dispatch Officer (DO)

9.9.2.7 “Punarbhava™” (www.punarbhava.in) - Web portal for ‘Divyangjan (Persons with Disabilities)’

Information related to different disability aspects viz. such as Disability Registration, Legal Instruments, Resources, Careers, Assistive Devices, Blogs, Accessible Content, Latest News, Events, Employment Opportunities, Publications, Useful Links, National Institutes, and feedback etc. is being disseminated through web portal. It is beneficial for Divyangjans, NGOs, professionals, policy makers, students, parents, community workers, parents and other stakeholders in the field of disabilities. The portal is accessible as per W3C guidelines. It also has a font resizer and color switcher options for accessibility. The portal is regularly updated and receives 12,000 average daily hits. The design of the portal is mobile compatible.



A Screenshot of ‘Punarbhava™’

9.9.2.8 Centralized System for Heart Rate Variability (cHRV) Analysis System

The project is being executed in collaboration with AIIMS, New Delhi with objective to make

HRVA technology available at remote places to digitally empower healthcare professionals across the country. HRV is an important human body performance indicator to assess the role of autonomic nervous system fluctuations in healthy individuals and patients. It offers prognostic information independent of and beyond that provided by traditional risk factors. Centralized HRV empowers medical community through reproducible and collaborative research platform developed using R and OpenCPU framework. The system creates database on HRV & associated health for benchmarking, clinical utility and policy making.



cHRV Dashboard

During the year, the system has been customised with additional features viz. User Management, Analysis of multiple RR files on single click, Mobile application for Digital ECG Machine to capture beat to beat (RR Interval) data and to upload the same on cHRV server for HRV analysis, Optimization of HRV in R Package etc. The application is running on a DIC server in its Mumbai office. So far 36 Medical Institutions have registered across the country.

9.9.2.9 Visual Speech Training System (VSTS) for children with Hearing Impairment (HI)

The objective is to develop a system for children with hearing impairment to provide visual feedback of articulatory efforts during speech production to serve as a speech training aid.

Under the project, a system was developed for vowel and vowel-like sounds and having two panels for displaying animation or analysis results for speech signal from the student and a teacher or reference speaker.

Now phase II is being implemented to reduce the processing delay by integrating the animation and signal processing on a single platform. The system will be developed for speech training of utterances with consonants and for training of supra-segmental features. It will provide 3D-like animation with integration of lateral cross-sectional view obtained by processing of the speech signal acquired using a microphone and frontal view acquired using a camera.

9.9.2.10 Information Technology Research Academy (ITRA)

ITRA, a national programme initiated by MeitY, was designed to help build a national resource for advancing the quality & quantity of R&D in Information & Communications Technologies and Electronics (IT for brevity) and its applications in IT

and related institutions across India. The pilot phase of ITRA ended on Dec 31, 2019. Implementation of ITRA was entrusted to Digital India Corporation. ITRA activities were focused on:

- i. Advancing quality and quantity of IT R&D
- ii. Increasing the number of academic/research institutions
- iii. Strengthening IT based problem solving and societal development
- iv. Forming centres of excellence through Teams of Institutions
- v. Solving major problems and undertake basic research
- vi. Focus areas encompassing high priority needs in IT or IT applications

For details please refer Chapter 5 Point No. 5.5.5

9.9.2.11 Visvesvaraya PhD Scheme for Electronics & IT

MeitY has entrusted DIC with implementation of the Scheme to enhance the number of PhDs in Electronic Design & Manufacturing (ESDM) and IT / IT enabled Services (ITES) sectors. The objective is to support 3,000 additional PhDs students (1,000 full time + 2,000 part time) in ESDM and IT / ITES and to support 200 Young Faculty to encourage & recognize their work in research & technology development.

Financial Components under “Visvesvaraya PhD Scheme”

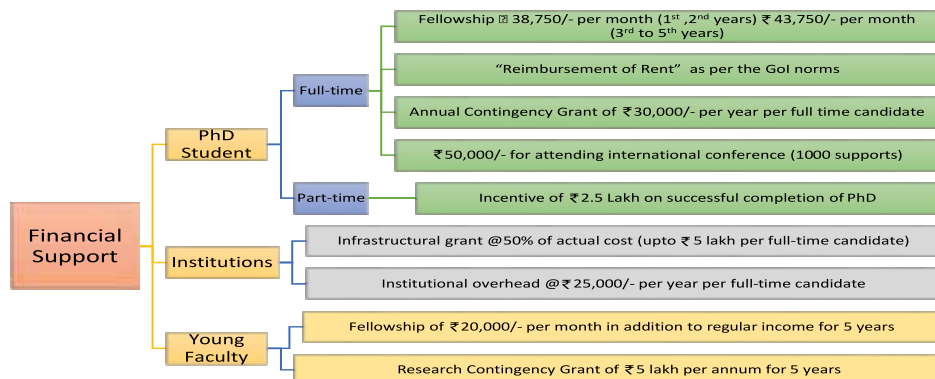

Status of the implementation of the Scheme:

- The fellowship under the scheme has been enhanced in Aug 2019 from current rates of Rs. 31,500/- (for 1st two years of PhD) and Rs. 35,000/- (3rd year onwards) to Rs. 38,750/- & Rs. 43,750/- respectively. The reimbursement of rent linked to fellowship has also been increased. The enhanced rates are applicable wef 1st April 2019.
- 1076 full-time and 746 part-time PhD seats have been allocated to 97 academic institutions under the scheme where 931 Full time & 295 part-time PhD candidates are currently enrolled.
- 154 faculty members were awarded 'Young Faculty Research Fellowship (YFRF)'.
- The PhD Scholars are pursuing research in the emerging technology areas such as Big Data, Blockchain, Machine Learning, Artificial Intelligence, Internet of Things, Cloud Computing, Cyber Security, Mobile communication, 5G communication, Quantum Computing, VLSI Design, Medical Electronics, Biotechnology, etc.
- 13 Research Scholars from 11 institutions reported filing of 15 patents.
- 2690 Research Papers published by the 785 Research Scholars.
- 112 PhD Candidates attended International Conferences.
- For assessment of quality of research of PhD fellows and "Young Faculty Research Fellowship" awardees supported under the Scheme, Workshops were conducted in different parts of the country where the shortlisted PhD Fellows along with their guides and awardees of "Young Faculty Research Fellowship" presented their research and the experts gave their suggestion for quality improvement.
- A total of 5 Workshops for Research Fellows (in Mumbai, Bengaluru, Visakhapatnam, Jaipur and Chandigarh covering around 950 Research Scholars) and 3 workshops for "Young Faculty Research fellowship (YFRF)" awardees have been held. Out of these workshops, 5th workshop of PhD Scholar (at PEC Chandigarh in July 2019)



Experts during 5th workshop of PhD Scholars at PEC Chandigarh



3rd Mid-term Evaluation Committee members at IIT Jodhpur

and 3rd workshop for YFRF Awardees (at IISc Bengaluru in May 2019) were held during FY 2019-20. Two Performance Reviews were held in Nov 2019 at IISc Bengaluru and IIT Delhi for 63 YFRF Awardees who have completed 2 years under the scheme.

- Research Papers of PhD fellows have been published in 3 exclusive issues (June 2017, March 2018 and June 2018) of CSI Transactions on ICT Journal published by Springer.
- The scheme has also helped the Institutions in up-gradation/creation of laboratory, equipment, etc.; playing a vital role in research activity, encouraging the students & young faculty researchers in technology development & creation of intellectual property in ESDM & IT/ITES sector.

Mid-Term Evaluation of Visvesvaraya PhD Scheme

- In August 2018, with the approval of Secretary,

MeitY constituted a Committee under the Chairmanship of Dr. Arabinda Mitra, Scientific Secretary, O/o. PSA to Gol for Mid-Term Evaluation of Visvesvaraya PhD scheme.

- A total of 3 meetings of the Evaluation Committee have been held. (3rd meeting at IIT Jodhpur on 3rd August 2019).
- The Evaluation Committee through interaction with the nodal officers of the Institutions, PhD Scholars and awardees of Young Faculty Research Fellowship from different institutions collected their feedback and observed that all have appreciated the scheme greatly. The scheme has built a momentum in the institutions throughout the country for enrolment of more PhD candidates in the area of ESDM & IT/ITES and has been able to make a good impact.
- The Evaluation Committee has recommended continuation of the scheme with annual intake of 300 Full time PhD seats and introduction of 50 “Post-Doctoral Fellowships”.

Chapter – 10

Other Matters



10.1 Use of Official Language Hindi in official work

In order to promote the use of Hindi in official work in the Ministry, a Monthly Incentive Scheme has also been started in addition to Annual Incentive Scheme for Noting & Drafting in Hindi. Under this Incentive Scheme, previously there were five prizes of ₹ 500/- each but in order to make this scheme more attractive the prize money has been increased from the ₹ 500/- per prize to ₹ 1000/- per prize and officers/employees writing at least 2,000 words in Hindi during the month can participate in this Incentive Scheme.

Hindi Pakhwada was organised by the Ministry during September 2019. During this period many competitions were held and winners were awarded. Besides, Hindi Pakhwada various competitions were also held during the year.

To ensure the implementation of official language

policy in the offices under the administrative control of this Ministry, official language inspection was done at STPI-Bengaluru, C-DAC-Bengaluru, C-DAC-Mumbai, SAMEER, Mumbai, C-DAC-Pune and C-MET, Pune.

During the period under report, various important documents like Annual Report, Outcome Budget, various Cabinet Notes, various Notes for Parliamentary Standing Committee, Replies to Parliament Questions, Questionnaire based on Demands for Grants, Power Point Presentation for Standing Committee, Follow-up Action Reports, Monthly Reports for the Cabinet and other miscellaneous documents were translated from English to Hindi.

10.2 RTI Matters

There is a RTI Cell in the Ministry, which is the central receiving point for RTI applications/appeals and responsible for overall coordination in respect

of RTI matters of MeitY and its organisations. MeitY and its Attached/Subordinate Offices/Societies are separate Public Authorities in terms of Section 2 (h) of RTI Act, 2005. Each of these Public Authorities has its own Central Public Information Officers (CPIOs)/Appellate Authorities (AAs). For any information relating to these organisations, applications need to be submitted to the concerned Public Authorities as per provisions of RTI Act, 2005. All Public Authorities have also hosted relevant inputs/documents on their respective websites, as required under Section 4 of the RTI Act. The relevant contents are reviewed and updated periodically by the concerned Public Authorities.

During the period from 01.01.2019 to 31.12.2019, 2095 RTI applications (1,821 online and 271 physical) were received in this Ministry. 102 numbers of appeals (83 online and 19 physical) also received during the period from 01.01.2019 to 31.12.2019. The applications received were related to MeitY and organisations under it. Aadhaar, Cyber Law, Social Media, Digital Payment, e-Governance, online gaming and internet websites were the main subjects on which large number of RTI applications received during the period from 01.01.2019 to 31.12.2019.

10.3 Public Grievances

Similar to RTI Cell, there is Public Grievances Cell in MeitY headed by Director (Public Grievance).

The grievances received in PG Cell through CPGRAM portal and also offline mode were mainly relate to the following:

- CSC
- Digital India/e-Services

Social Media

- MyGov
- Digital Payment
- Aadhaar

During the period from 01.01.2019 to 31.12.2019, 7250 grievances were received and out of these, 6,719 were disposed of. Detailed information for this year in tabulated form is shown below:

Grievance Source	Brought Forward	Receipt During Period	Total Receipt	Case Disposed During Period	Closing Balance
DARPG	17	408	425	401	24
Local/Internet	135	4426	4561	4274	287
Pension	4	92	96	84	12
PMO	2	29	31	28	3
President Secretariat	99	2038	2137	1932	205
Total	257	6993	7250	6719	531

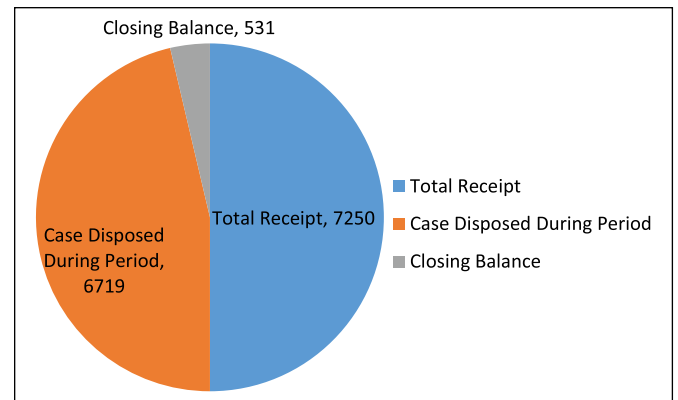

Pie Chart showing the details of grievances received during the period from 01.01.2019 to 31.12.2019.

10.4 Information and Documentation Centre (Library)

This Ministry has a spacious well planned Library viz Information and Documentation Centre (I&DC), with an inventory of books and journals. It uses RFID based Library Management System to manage issue & return of Books/Journals. I&DC also provides various other services like inter-Library loan facility to the officials of the Ministry through DELNET (Developing Library Network) and also arranges books from libraries of various other Organizations. Services are also provided to

the retired officials of the Ministry and trainees who undertake projects in the Ministry.

The Information & Documentation Centre possesses approximately 30,150 books on various subjects including Electronics, Computer, IT, Computer Languages, Fiction. Also has some books on Hindi and English literature. I&DC procures on an average 50 books and approximately 50 Journals per annum. Currently, e-books service (Books 24x7) is also made available to the authorized users.

The Ministry is spearheading an Intra-Ministerial initiative viz the Library Consortium, Ministry of Electronics & Information Technology (MCIT). Consortium of the Ministry (MCIT Consortium) comprises the users from the National Informatics Centre (NIC), C-DAC, NIELIT, SAMEER, C-MET, STQC Directorate, STPI, CCAERNET India, C-DOT. The Ministry provides on-line access to various e-resources i.e. IEEE Journals/Transactions/Proceedings, IEE Journals/ Proceedings, ACM digital library and ISO Standards to its users through MCIT Library Consortium.

10.5 Parliament Matters

During the year, 217 Parliament Questions in Lok Sabha (10 Starred & 207 Unstarred) and 129 Parliament Questions in Rajya Sabha (10 Starred & 119 Unstarred) were admitted and handled by the Parliament Section, MeitY. These were mainly related to Digital Payments, National e-Governance Plan, Cyber Security, Aadhaar Sewa Kendra, Digital India Programme, Misuse of Social Media, Tracing of WhatsApp Rogue Message, Use of Blockchain Technology, Privacy Breach on Whatsapp, Data Centre and Security, Domestic production of consumer electronics, National Super Computing Mission, BPO Promotion Scheme, Circulation of Fake News, MSIPS, Smartphone Market in India, Circulation of Malicious Content, Online Child Sexual Abuse, Digital Locker, Digital Literacy under PMGDISHA, Employment creation through Call Centers, Breach of Biometric Information, Drone Manufacturing Hub, Indian

Cyber Crime Coordination Centre and Cyber Police Force, Import of Television from Vietnam, Cyber attacks on banking and cashless networks, Ban on Mobile Apps., Incentives for Electronics Industry, Fingerprint Authentication, OTT Streaming Service Providers, Data Theft and Misuse of Mails, Web based services in North Eastern States, Boosting chip manufacturing, National Policy on Software Products, Linking of Aadhaar and Driving License, Fake news through digital media, Reducing frictional digital payments, Controlling streaming of online contents, Updation of Government Websites, Artificial Intelligence, Safety of LED items, Number of Law suits against the Department, Funds used under Corporate Social Responsibility, Misuse of data by companies to manipulate electoral process, Development of economy through data localization, Guidelines for social media, Unauthorized/Illegal Software and Demand of IT Professionals.

Department Related Parliamentary Standing Committee on Information Technology have laid following Reports on the Table of Lok Sabha:-

- Action Taken by the Government on the Observations/Recommendations of the Committee contained in their Forty-Sixth Report (Sixteenth Lok Sabha) on 'Demands for Grants (2018-19)' relating to the Ministry of Electronics and Information Technology on 02.01.2019.
- Review of National Digital Literacy Mission (NDLM)– Problems and Challenges relating to the Ministry of Electronics and Information Technology on 02.01.2019.
- Action Taken by the Government on the Observations/Recommendations of the Committee contained in their Forty-Third Report(Sixteenth Lok Sabha) on Expansion of Rural BPOs and Challenges faced by them relating to the Ministry of Electronics and Information on 02.01.2019.

The Standing Committee on Information Technology has selected the following subjects for discussion during the year 2019-20:-

- Citizen data Security and Privacy
- Digital Payment and Online Security measures for data protection.
- Review of functioning of Unique Identification Authority of India (UIDAI)
- Safeguarding citizens' rights and prevention of misuse of social/online news media platforms including special emphasis on women security in the digital space
- Promotion of Electronics/IT Hardware Manufacturing Sector and measures for reduction of imports
 - Policy issues in Information Technology including cross border data flows, Artificial Intelligence (AI) and Internet of Things (IoT) etc.

The following Annual Reports of Societies of the Ministry of Electronics and Information Technology have been laid on the Table of the House (Lok Sabha and Rajya Sabha):-

- NIELIT – 11th July, 2019 (Rajya Sabha)
- STPI – 17th July, 2019 (Lok Sabha) and 25th July, 2019 (Rajya Sabha)
- SAMEER – 17th July, 2019 (Lok Sabha) and 25th July, 2019 (Rajya Sabha).

10.6 Gender Empowerment/Prevention of sexual harassment of women at work place

No case of sexual harassment has been received in r/o MeitY.

10.7 Activities undertaken for the benefit of Differently abled Persons “Punarbhava™” (www.punarbhava.in) - Web portal for ‘Divyangjan (Persons with Disabilities)’

Information related to different disability aspects viz. such as Disability Registration, Legal Instruments, Resources, Careers, Assistive Devices, Blogs, Accessible Content, Latest News, Events, Employment Opportunities, Publications, Useful Links, National Institutes, and feedback etc. is being disseminated through web portal. It is beneficial for

Divyangjans, NGOs, professionals, policy makers, students, parents, community workers, parents and other stakeholders in the field of disabilities. The portal is accessible as per W3C guidelines. It also has a font resizer and color switcher options for accessibility. The portal is regularly updated and receives 12,000 average daily hits. The design of the portal is mobile compatible.

Accessible India Campaign: Development/renovation of Government/State Government websites to make them accessible for Persons with Disabilities (PwD) as per GIGW/WCAG. 2.0 (A, AA level)

For details may please see 9.10.2.6 of Chapter 9.

Visual Speech Training System (VSTS) for children with Hearing Impairment (HI)

The objective is to develop a system for children with hearing impairment to provide visual feedback of articulatory efforts during speech production to serve as a speech training aid.

For details may please see 9.9.2.9 of Chapter 9.

Initiatives on Accessibility

A National Policy on Universal Electronic Accessibility was formulated by Ministry of Electronics and Information Technology (MeitY) and it was notified on October 25, 2013. Details are available at paragraph 2.4.3. of Chapter 2.

10.8 Details related to the Vigilance cases

Vigilance Unit, Ministry of Electronics and Information Technology is the nodal Unit for handling all vigilance matters of the Ministry of Electronics and Information Technology and the Societies under its administrative control. This Unit is presently headed by Additional Secretary who has also been appointed as Chief Vigilance Officer (CVO) by Central Vigilance Commission. He is assisted by Deputy Director and one Unit headed by a Section Officer. The CVO looks into the Vigilance matters of all organizations under MeitY. Although, the Autonomous Societies under MeitY have their own CVOs, their appointment and

the overall functioning of Vigilance matters of these organizations vests with the CVO, MeitY. Each of the Attached/Subordinate Offices under MeitY has their own vigilance set up in their respective organizations who work in close coordination with the Vigilance Unit of this Ministry.

During the year 2019, about 149 complaints were received in Vigilance Unit, MeitY out of which 63 complaints were received from Central Vigilance Commission and 86 complaints from different platforms including Central Bureau of Information (CBI), Prime Ministers' Office, Public Grievance/PIDPI Portal etc. The complaints received related to MeitY and attached/subordinate offices and Autonomous Societies under MeitY were mainly alleging to favoritism/nepotism and corruption in recruitment, violation of CVC guidelines in tender process, misuse of official position, insubordination, harassment, bribery, etc.

The complaints were examined and those relating to concerned CVOs/administration were forwarded to the respective organizations. Besides, these, during the year 2019, about 13 major complaints were taken up for investigation. 7 cases have been concluded with imposition of major penalty/minor penalty/closure of the case/issue of preventive measures. Major Penalties have been imposed on two Officers and Minor Penalty of Censure has been imposed upon 6 officers. Displeasure Order has been issued in respect of 1 Officer. The penalty cases have been processed in consultation with Central Vigilance Commission. During the year, action has also been initiated against an officer working in organization under MeitY on the basis of CBI inquiry/Court's judgment. Further two work orders were taken up for Intensive Examination and necessary communications have been issued to the concerned organizations.

In order to mitigate potential risk of corruption, Vigilance Unit of MeitY arranges vigilance seminars/ training programmes in the Offices under the administrative control of this Ministry situated in various parts of the country and also conducts token inspection of records from time

to time. These programmes are arranged for the benefit of all concerned to prepare the best practice chart at all the levels to bring about change in work culture and work ethics and to develop transparency and minimize discretionary power. At these meets besides their vigilance functionaries, other officers/staff of these units are also invited in order to create vigilance awareness amongst all. In the year 2019 for sensitizing the officers of MeitY and its organizations the officers of Vigilance Unit visited centers i.e. C-DAC, Thiruvananthapuram, NIC, Thiruvananthapuram and C-DAC, Bengaluru. Officers of Vigilance Unit also associated themselves in the Vigilance investigation teams/committee setup to conduct the preliminary inquiry of the complaint pertaining to corruption charges of officers working in one of the organizations of MeitY and submitted the report for necessary action.

This year Vigilance Awareness Week had been observed from 28th October, 2019 to 2nd November, 2019 in MeitY as well as other organizations under MeitY with the theme "Integrity-A way of life (ईमानदारी- एक जीवन शैली)". In MeitY, a 'Pledge' as drafted by CVC was administered by Additional Secretary on 28th October, 2019 to all officers/staff of this Ministry.

Other than these, a total of 49 Folders on Annual Property Returns of officers/officials of MeitY were scrutinized with a view to check possession of assets disproportionate to known sources of income, non-intimation of transaction of property and necessary directions were conveyed to the concerned authorities.

Besides in order to improve systems and procedures to reduce and eliminate corruption and discretion, OM/instructions on preventive measures on recruitment/procurement/posting-transfer were issued by Vigilance Unit, MeitY at intervals of time. In its routine functioning more than 250 requests for grant of Vigilance Clearance had been received from MeitY/its organizations which had been examined and communicated accordingly. Vigilance Unit has also been sending reports to CVC/CBI/DoPT in a time bound manner.

Summary of Important Audit Observations

Sl. No.	Year	No. of Paras/ PAC reports on which ATNs have been submitted to PAC after vetting by Audit	Details of the Paras/PAC reports on which ATNs are pending		
			No. of ATNs not sent by the Ministry even for the first time	No. of ATNs sent but returned with observations and Audit is awaiting their resubmission by the Ministry	No. of ATNs which have been finally vetted by audit but have not been submitted by the Ministry to PAC
1.	2002-03	-	Nil	-	Nil
2.	2003-04	-	Nil	-	Nil
3.	2004-05	-	Nil	-	Nil
4.	2005-06	-	Nil	-	Nil
5.	2006-07	-	Nil	-	Nil
6.	2007-08	-	Nil	-	Nil
7.	2008-09	-	Nil	-	Nil
8.	2009-10	-	Nil	-	Nil
9.	2010-11	-	Nil	-	Nil
10.	2011-12	-	Nil	-	Nil
11.	2012-13	-	Nil	-	Nil
12.	2013-14	-	Nil	-	Nil
13.	2014-15	-	Nil	-	Nil
14.	2015-16	-	Nil	-	Nil
15.	2016-17	-	Nil	-	Nil
16.	2017-18	-	Nil	-	Nil
17.	2018-19	-	Nil	-	Nil

Appendix II

Annual Budget 2020-21

Sl. No.	Scheme/Non-Schemes	Budgetary Support (Rupees in crore)
Non-Schemes		
1	MeitY Secretariat	116.03
2	National Informatics Centre	1285.00
3	Regulatory Authorities	274.00
3.1	Standardisation Testing and Quality Certification (STQC)	125.00
3.2	Cyber Security (CERT-In)	140.00
3.3	Controller of Certifying Authorities (CCA)	9.00
4	Assistance to Autonomous & Other Bodies	1266.00
4.1	Centre for Development of Advanced Computing (C-DAC)	127.00
4.2	Society for Applied Microwave Electronics Engineering and Research (SAMEER)	98.00
4.3	Centre for Materials for Electronics Technology (C-MET)	50.00
4.4	Digital India Corporation (DIC)	6.00
4.5	Unique Identification Authority of India (UIDAI)	985.00
	Sub-Total (Non-Scheme)	2941.03
5	Digital India Programme	3958.00
5.1	Manpower Development	430.00
5.2	Electronic Governance (incl. EAP)	425.00
5.3	National Knowledge Network	400.00
5.4	Promotion of Electronics & IT Hardware Mfg (MSIPS, EDF & Manufacturing Clusters)	980.00
5.5	Promotion of IT/ITeS Industries	170.00
5.6	R&D in IT/Electronics/ CCBT	762.99
5.7	Cyber Security Projects (NCCC & Others)	170.00
5.8	Promotion of Digital Payments	220.00
5.9	Pradhan Mantri Digital Saksharta Abhiyan	400.00
5.10	Champion Services Sector Scheme	0.01
	Sub-Total (Scheme)	3958.00
	TOTAL (SCHEME & NON-SCHEME)	6899.03

Employees' Structure

(Total and SCs/STs/PWDs as on 01st January, 2020)

Group	Permanent/ Temporary	Total No. of employees	SC	% of SC w.r.t. total employees	ST	% of ST w.r.t. total employees	PWDs	% of PWDs w.r.t. total employees
Group A	Permanent							
	(i) Other than lowest rung of Group A	178	28	15.73	10	5.62	3	1.69
	(ii) Lowest rung of Group A	1	0	0	0	0	0	0
	Temporary							
	(i) Other than lowest rung of Group A	0	0	0	0	0	0	0
	(ii) Lowest rung of Group A	9	1	11.11	0	0	2	22.22
Group B (Gazetted)	Permanent	46	8	17.39	4	8.7	1	2.17
	Temporary	0	0	0	0	0	0	0
Group B (Non- Gazetted)	Permanent	78	18	23.08	6	7.69	2	2.56
	Temporary	2	0	0	0	0	0	0
Group C	Permanent	158	42	26.58	10	6.33	5	3.16
	Temporary	30	4	13.33	1	3.33	0	0
	TOTAL	502	101	20.12	31	6.18	13	2.59

Appendix IV

List of Abbreviations

AEPS	-	Aadhaar Enabled Payment System
AI	-	Artificial Intelligence
BHIM	-	Bharat Interface for Money
BOSS	-	Bharat Operating System Solutions
BSNL	-	Bharat Sanchar Nigam Limited
C-DAC	-	Centre for Development of Advanced Computing
CFC	-	Common Facility Centre
CSC	-	Common Services Centre
CTDP	-	Comprehensive Telecom Development Plan
C2SD	-	Chip to System Design
DoT	-	Department of Telecommunications
DIC	-	Digital India Corporation
DSC	-	Digital Signature Certificate
EMC	-	Electronics Manufacturing Clusters
ERNET	-	Education and Research Network
FINTECH	-	Financial Technologies
FOSS	-	Free and Open Source Software
FSOC	-	Free Space Optical Connectivity
GeM	-	Government eMarketplace
HRD	-	Human Resource Development
IIFPT	-	Indian Institute of Food Processing Technology

IIT	-	Indian Institute of Technology
IoT	-	Internet of Things
JAM	-	JanDhan, Aadhaar and Mobile
NCoG	-	National Centre of Geo-informatics
NeGD	-	National e-Governance Division
NER	-	North Eastern Region
NERS	-	Nationwide Emergency Response System
NIC	-	National Informatics Centre
NIELIT	-	National Institute of Electronics & Information Technology
NLCPR	-	Non-Lapsable Central Pool of Resources
MHA	-	Ministry of Home Affairs
NKN	-	National Knowledge Network
MNRE	-	Ministry of New and Renewable Energy
MSDE	-	Ministry of Skill Development And Entrepreneurship
M-SIPS	-	Modified Special Incentive Package Scheme
ORS	-	Online Registration System
PFMS	-	Public Financial Management System
PMGDISHA	-	Pradhan Mantri Gramin Digital Saksharta Abhiyan
SDC	-	State Data Centre
SEZ	-	Special Economic Zone
SMDP	-	Special Manpower Development Programmes
SSDG	-	State Service Delivery Gateway
STPI	-	Software Technology Parks of India
SWAN	-	State Wide Area Network

MeitY	-	Ministry of Electronics and Information Technology
MDoNER	-	Ministry of Development for North Eastern Region
NEBPS	-	North East BPO Promotion Scheme
UIDAI	-	Unique Identification Authority of India
UMANG	-	Unified Mobile App for New-Age Governance
UPI	-	Unified Payment Interface
USOF	-	Universal Services Obligation Fund
USSD	-	Unstructured Supplementary Service Data
ZP	-	Zilla Parishad

